



Operation Manual

PRODUCT NAME

High Pressure E/P Regulator

MODEL/ Series/ Product Number

ITVX Series

- Install and operate the product only after reading the Operation Manual carefully and understanding its contents.
- Specifically, read the safety instructions carefully.
- Keep this operation manual available whenever necessary.
- This product is only for blowing. This product does not have sufficient control for applications other than blowing (driving, sealing etc.).

SMC Corporation

Contents

Contents	P1
Safety Instructions	P2
Handling precautions	P4
Wiring method	P6
Setting method	P8
Key locking function	P9
Setting of min. pressure, max. pressure and switch output	P10
Mode of switch output	P11
Reset function	P12
Error indicating function	P12
Detail setting mode	P13
Gain setting	P13
Zero clear	P14
Initialize	P15
LED display	P15



High Pressure E/P Regulator Safety Instructions

These safety instructions are intended to prevent hazardous situations and/or equipment damage. These instructions indicate the level of potential hazard with the labels of "Caution," "Warning" or "Danger." They are all important notes for safety and must be followed in addition to International Standards (ISO/IEC)*1), and other safety regulations.

*1) ISO 4414: Pneumatic fluid power -- General rules relating to systems.

ISO 4413: Hydraulic fluid power -- General rules relating to systems.

IEC 60204-1: Safety of machinery -- Electrical equipment of machines .(Part 1: General requirements)

ISO 10218-1992: Manipulating industrial robots -Safety.

etc.



Caution

Caution indicates a hazard with a low level of risk which, if not avoided, could result in minor or moderate injury.



Warning

Warning indicates a hazard with a medium level of risk which, if not avoided, could result in death or serious injury.



Danger

Danger indicates a hazard with a high level of risk which, if not avoided, will result in death or serious injury.

Warning

1. The compatibility of the product is the responsibility of the person who designs the equipment or decides its specifications.

Since the product specified here is used under various operating conditions, its compatibility with specific equipment must be decided by the person who designs the equipment or decides its specifications based on necessary analysis and test results.

The expected performance and safety assurance of the equipment will be the responsibility of the person who has determined its compatibility with the product.

This person should also continuously review all specifications of the product referring to its latest catalog information, with a view to giving due consideration to any possibility of equipment failure when configuring the equipment.

2. Only personnel with appropriate training should operate machinery and equipment.

The product specified here may become unsafe if handled incorrectly.

The assembly, operation and maintenance of machines or equipment including our products must be performed by an operator who is appropriately trained and experienced.

3. Do not service or attempt to remove product and machinery/equipment until safety is confirmed.

1. The inspection and maintenance of machinery/equipment should only be performed after measures to prevent falling or runaway of the driven objects have been confirmed.

2. When the product is to be removed, confirm that the safety measures as mentioned above are implemented and the power from any appropriate source is cut, and read and understand the specific product precautions of all relevant products carefully.

3. Before machinery/equipment is restarted, take measures to prevent unexpected operation and malfunction.

4. Contact SMC beforehand and take special consideration of safety measures if the product is to be used in any of the following conditions.

1. Conditions and environments outside of the given specifications, or use outdoors or in a place exposed to direct sunlight.

2. Installation on equipment in conjunction with atomic energy, railways, air navigation, space, shipping, vehicles, military, medical treatment, combustion and recreation, or equipment in contact with food and beverages, emergency stop circuits, clutch and brake circuits in press applications, safety equipment or other applications unsuitable for the standard specifications described in the product catalog.

3. An application which could have negative effects on people, property, or animals requiring special safety analysis.

4. Use in an interlock circuit, which requires the provision of double interlock for possible failure by using a mechanical protective function, and periodical checks to confirm proper operation.



High Pressure E/P Regulator Safety Instructions

Caution

1. The product is provided for use in manufacturing industries.

The product herein described is basically provided for peaceful use in manufacturing industries.

If considering using the product in other industries, consult SMC beforehand and exchange specifications or a contract if necessary.

If anything is unclear, contact your nearest sales branch.

Limited warranty and Disclaimer/Compliance Requirements

The product used is subject to the following "Limited warranty and Disclaimer" and "Compliance Requirements".

Read and accept them before using the product.

Limited warranty and Disclaimer

1. The warranty period of the product is 1 year in service or 1.5 years after the product is delivered, whichever is first.*2)

Also, the product may have specified durability, running distance or replacement parts. Please consult your nearest sales branch.

2. For any failure or damage reported within the warranty period which is clearly our responsibility, a replacement product or necessary parts will be provided.

This limited warranty applies only to our product independently, and not to any other damage incurred due to the failure of the product.

3. Prior to using SMC products, please read and understand the warranty terms and disclaimers noted in the specified catalog for the particular products.

***2) Vacuum pads are excluded from this 1 year warranty.**

A vacuum pad is a consumable part, so it is warranted for a year after it is delivered.

Also, even within the warranty period, the wear of a product due to the use of the vacuum pad or failure due to the deterioration of rubber material are not covered by the limited warranty.

Compliance Requirements

1. The use of SMC products with production equipment for the manufacture of weapons of mass destruction (WMD) or any other weapon is strictly prohibited.

2. The exports of SMC products or technology from one country to another are governed by the relevant security laws and regulation of the countries involved in the transaction. Prior to the shipment of a SMC product to another country, assure that all local rules governing that export are known and followed.

⚠ Warning

If oxygen is used as the fluid, it can lead to serious and unforeseen risks. However, it is possible to manage and control the risk of hazards and economic loss. In order to use the product safely, it should only be handled by personnel with appropriate knowledge, with support from a suitably qualified specialist.

Oxygen gas increases the susceptibility of substances to burning, can be ignited by frictional heat and static electricity, and makes metal and seal materials burn. Therefore, flush the piping thoroughly and mount a suitable filter to prevent foreign matter such as metal powder and dust from entering the product.

Take safety measures by installing safety devices (e.g. a circuit that stops the supply of oxygen gas) to prevent fire and explosion in the event of failure, taking flameproof safety standards into consideration.

Since there is an exhaust port on the product, connect the piping in order to exhaust oxygen.
Do not block the exhaust port.

Handling precautions

⚠ Caution

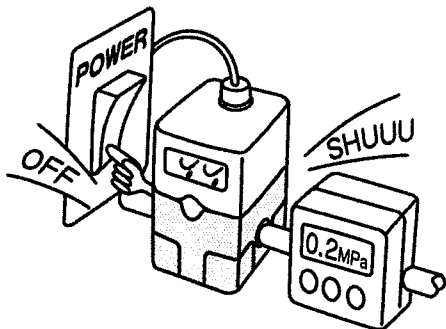

If the power supply to this product is turned off due to a power failure during normal operation, the output on the secondary side will be held and air will flow continuously.

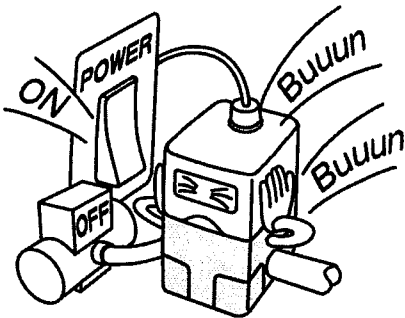

If supply pressure to this product is interrupted or shut off, while the power is still on, the internal solenoid valve will continue to operate and a humming noise will be generated.

Turn off the power supply when supply pressure is interrupted or shut off, since the life of the product may be shortened.

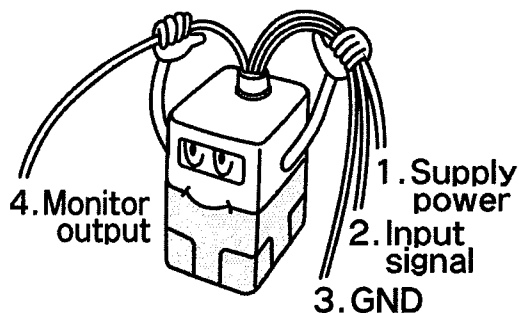

The optional cable connector is a 4 wire type.

When the monitor output (analogue output or switch output) is not being used, prevent the unused wires from touching the other wires, as a malfunction could occur.

 **Caution**

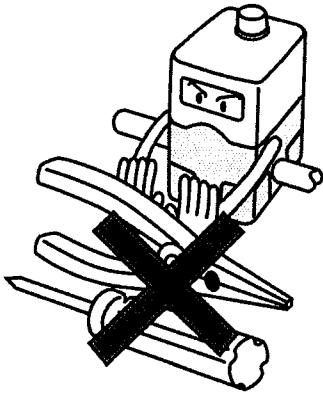

This product is adjusted to specification at the time of shipment from the factory. Avoid careless disassembly or removal of parts, as this can lead to malfunction.

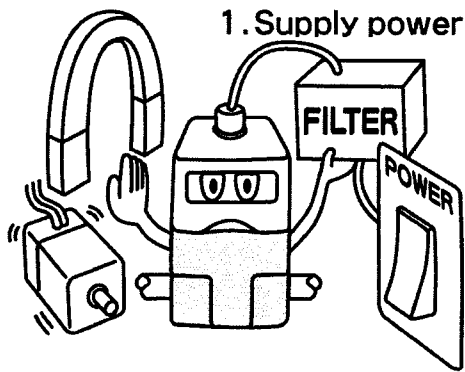

Take the following steps to avoid malfunction due to noise.

1. Install a line filter etc. to the AC power line to reduce / eliminate power supply noise.
2. Avoid malfunction due to noise by installing this product and its wiring away from strong electric fields, such as those of motors and power cables, etc.
3. Be sure to implement protective measures against load surge for inductive loads (solenoid valves, relays etc.).
4. Turn off the power supply before inserting or removing the connector.
5. Ground the F.G. terminal at the front of the main body.

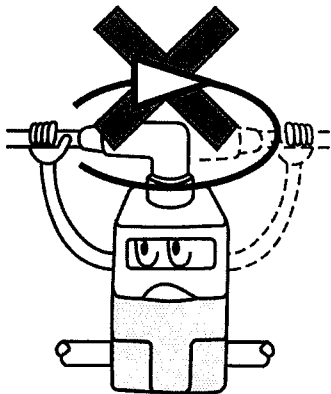

Please note that the right angled cable connector does not rotate and is limited to only one entry direction.

Wiring method

Wiring diagram (Ground the F.G. terminal)



Ground the F.G. terminal at the front of the main body

If the ground terminal (F.G.) is not used, this product may not operate correctly due to noise. If the field ground fluctuates due to noise, it may affect the operation of the product.

Wiring diagram (Power supply and input signal)



- ① Proceed carefully, as incorrect wiring can cause damage.
- ② Use a DC power supply with sufficient capacity and a low ripple.
- ③ Turn off the power supply to remove and insert the connector.
- ④ Never rotate the right angled type connector as it is not designed to rotate.

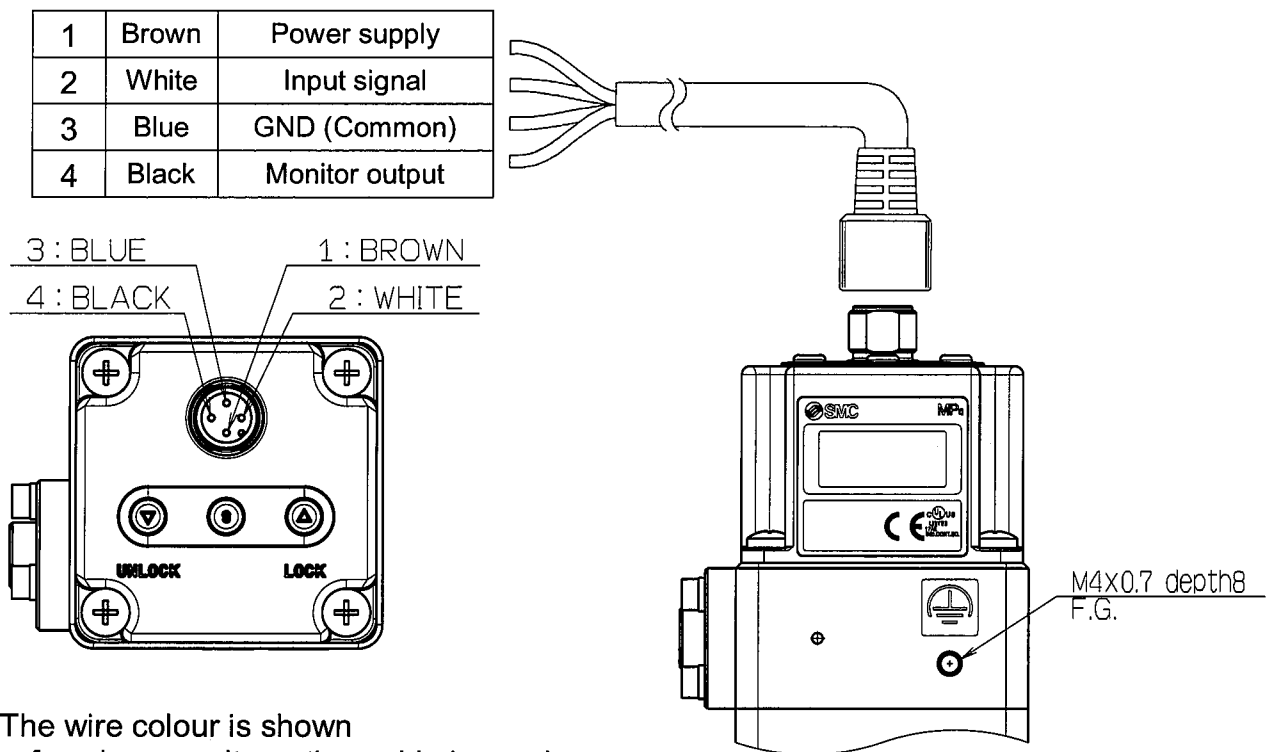

(Note) The wire colour is shown for when an alternative cable is used.

Current / Voltage type (ITVX2030-0, ITVX2030-1, ITVX2030-2, ITVX2030-3)

Power supply	24 VDC	
Input signal	4~20mADC	(ITVX2030-0)
	0~20mADC	(ITVX2030-1)
	0~ 5VDC	(ITVX2030-2)
	0~10VDC	(ITVX2030-3)

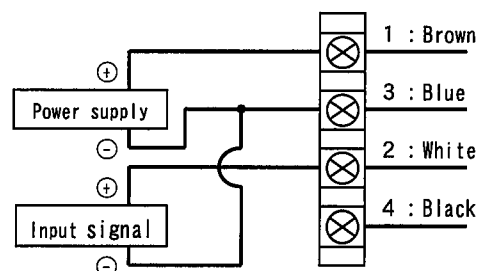

Wiring diagram (Monitor output)



Caution

When the monitor output is not being used, prevent the unused wires from touching the other wires, as this can cause a malfunction.

Analogue output - Voltage type
(ITVX2030-※1)

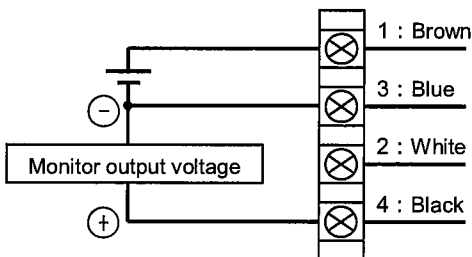

Only use equipment with a minimum load impedance of 100 kΩ.

Analogue output - Current (sink) type
(ITVX2030-※4)

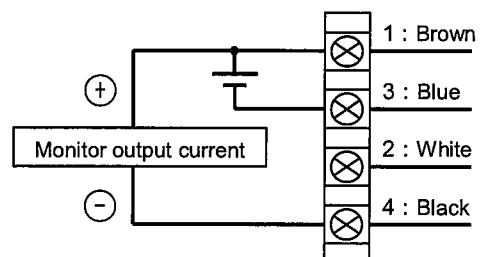

Only use equipment with a maximum load impedance of 250 Ω.

Switch output - NPN type
(ITVX2030-※2)

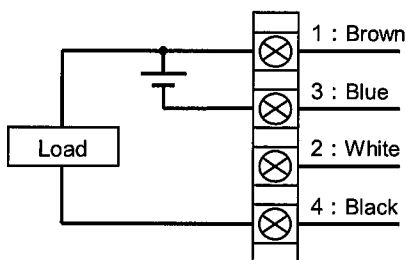

When a current of approx.150 mA or more is applied, the over current circuit will operate, "Er.5" will be displayed and the operation will stop.
Please install a load to give an output current of 80 mA or less.

Switch output - PNP type
(ITVX2030-※3)

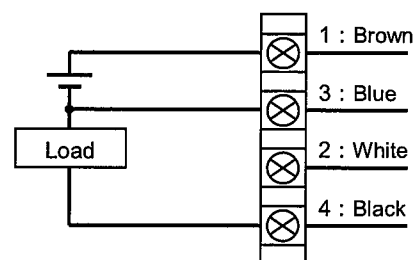

When a current of approx.150 mA or more is applied, the over current circuit will operate, "Er.5" will be displayed and the operation will stop.
Please install a load to give an output current of 80 mA or less.

Setting method

Caution

- ① If an incorrect key is pressed or incorrect information is displayed during setting, power must be turned off and the procedure started again.
- ② It is recommended that the settings are changed without supply pressure. The product operates immediately maximum and minimum pressures are set and the S-key is pressed.
- ③ It is recommended that the minimum pressure is output when air is supplied to the inlet, even if the input signal has not been entered.
- ④ Output pressure from this product and state of operation are changed by changing of each setting and function. Each setting and function should be operated by trained and experienced operator.

Flow of the setting

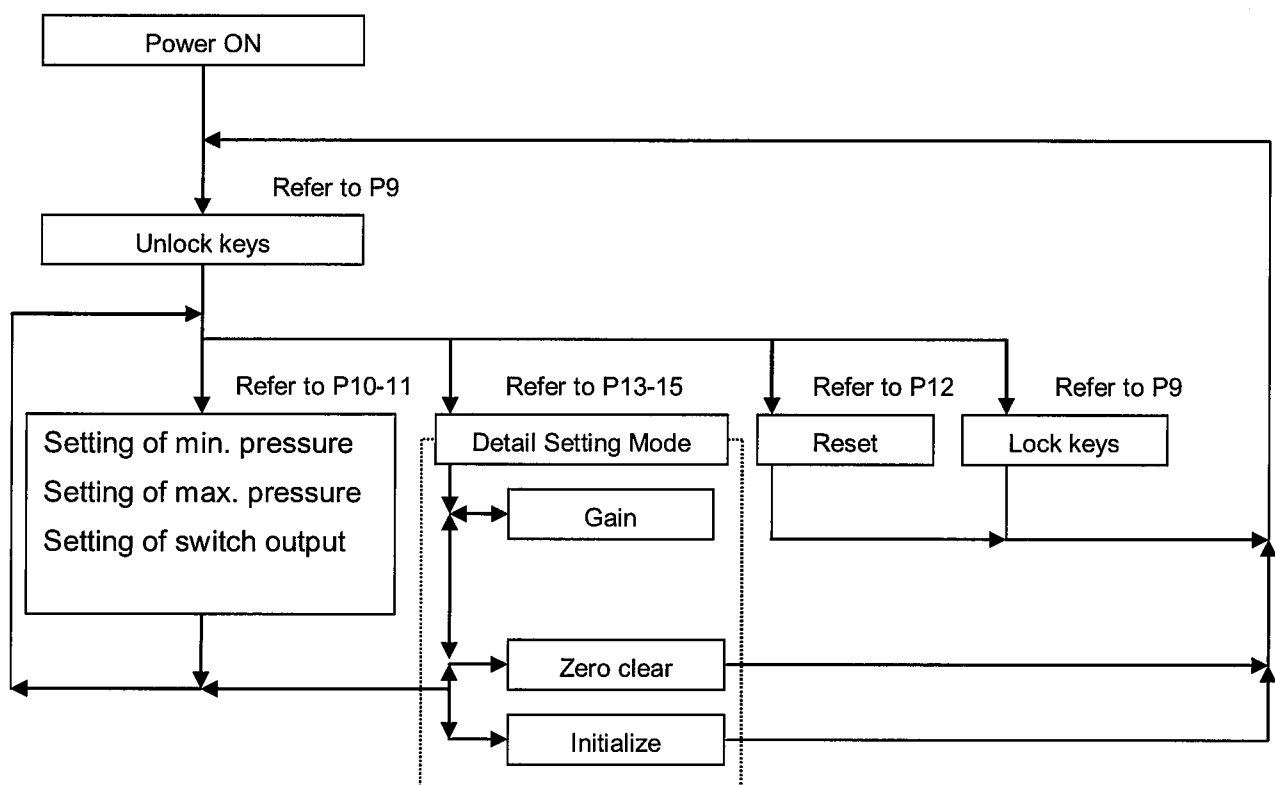

(Note1) Please refer to each section for the operation method.

(Note2) The function of the setting of switch output refers to the switch output type only.

Key locking function

Caution

The keys are locked after turning the power on and can not be operated.

Unlocking the keys

No	Key operation	LED Display
①		(current) pressure is displayed
②	Press ▽ key for 2 seconds or more.	<i>LOC</i> is displayed
③		<i>LOC</i> flashes on the display
④	Press S-key	
⑤		<i>unL</i> is displayed for approx. 1 second
⑥	Key lock is released	(current) pressure is displayed

(Note) ④ Press △ key to cancel.

Locking the keys

No	Key operation	LED Display
①		(current) pressure is displayed
②	Press △ key for 2 seconds or more.	<i>unL</i> is displayed
③		<i>unL</i> flashes on the display
④	Press S-key	
⑤		<i>LOC</i> is displayed for approx. 1 second
⑥	Keys are locked	(current) pressure is displayed

(Note) ④ Press ▽ key to cancel.

Setting of min. pressure, max. pressure and switch output

No	Key operation	LED Display
①	Unlock keys (refer to P9)	
②	Press S-key	
③	Set the minimum pressure by using the Δ and ∇ keys.	$F_1 \leftrightarrow 000$ (displayed alternately) * Adjusting range: Refer to Note 1 to 6
④	Press S-key	
⑤	Set the maximum pressure by using the Δ and ∇ keys.	$F_2 \leftrightarrow 300$ (displayed alternately) * Adjusting range: Refer to Note 1 to 6
⑥	Go to No. ⑪ for monitor output : analogue output (voltage and current) type.	
⑦	Press S-key	
⑧	Set the P_1 by using the Δ and ∇ keys.	$P_1 \leftrightarrow 300$ (displayed alternately)
⑨	Press S-key	
⑩	Set the P_2 by using the Δ and ∇ keys.	$P_2 \leftrightarrow 300$ (displayed alternately)
⑪	Press S-key	Return to (current) pressure display.
⑫	Lock keys (refer to P9)	

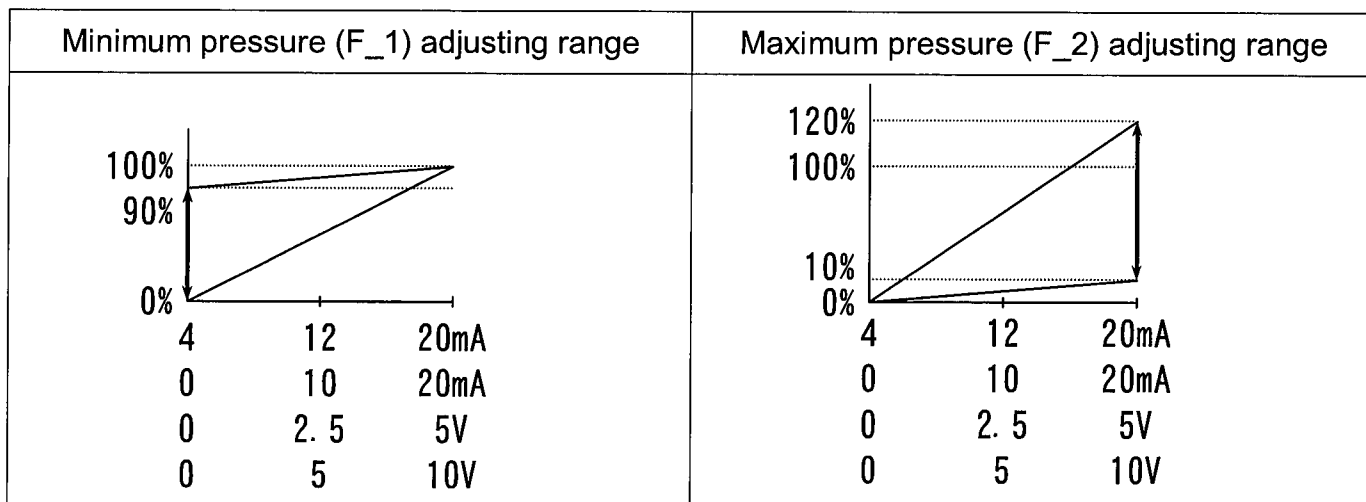

(Note1) F_1 is adjustable in a range from 0% to 90% of the rated value.

(Default value : 0%=0.00MPa)

(Note2) F_2 is adjustable in a range from 10 to 120% of the rated value.

(Default value : 100%=3.00MPa)

(Note3) Do not input the signal as like output the pressure of more than 100%.

Please use in a range of rating.

(Note4) The difference between F_1 and F_2 is adjustable in a range of 10% of the rated value.

(Note5) The adjustment like making the relation of F_1 > F_2 is not available.

(Note6) The numbers (3.00 etc) on the LED display indicate the secondary pressure.

Mode of switch output

The following operation types are available by setting P_1 and P_2.

(Note) This function is available for monitor output: switch output type. (ITVX2030-※2, -※3)

■ $P_1 < P_2$:

Window comparator mode

■ $P_1 \geq P_2$:

Hysteresis mode

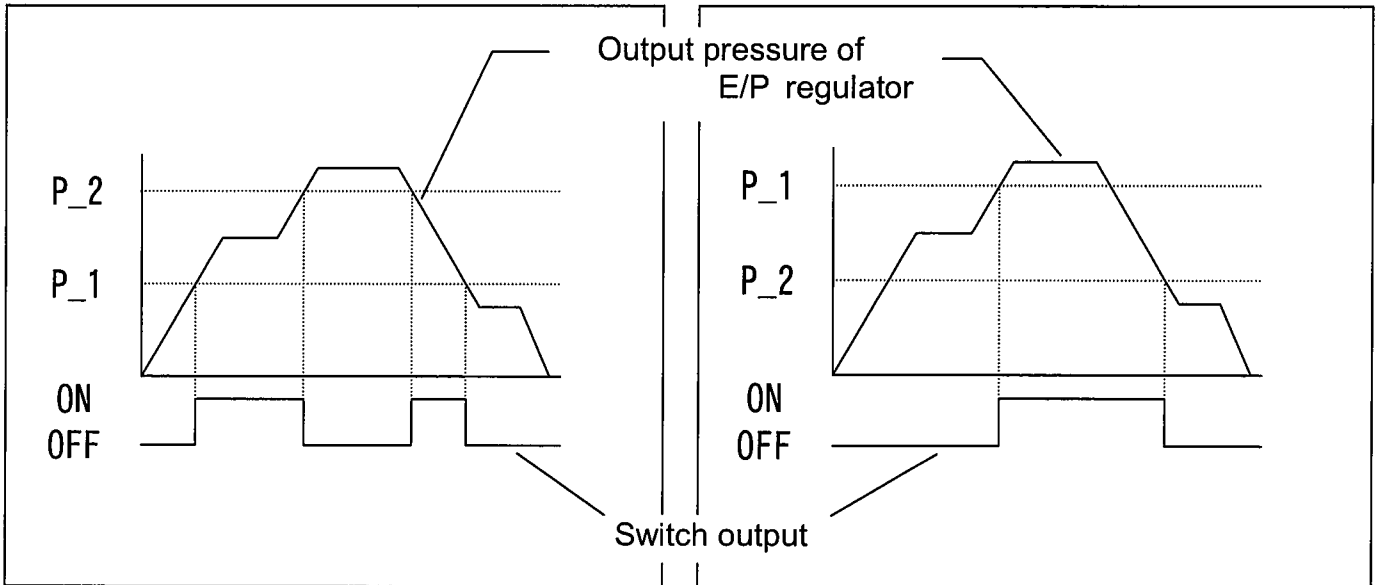

■ $P_1 = P_2 = 0$: Out of range mode

(The switch output turns on when set pressure is achieved.)

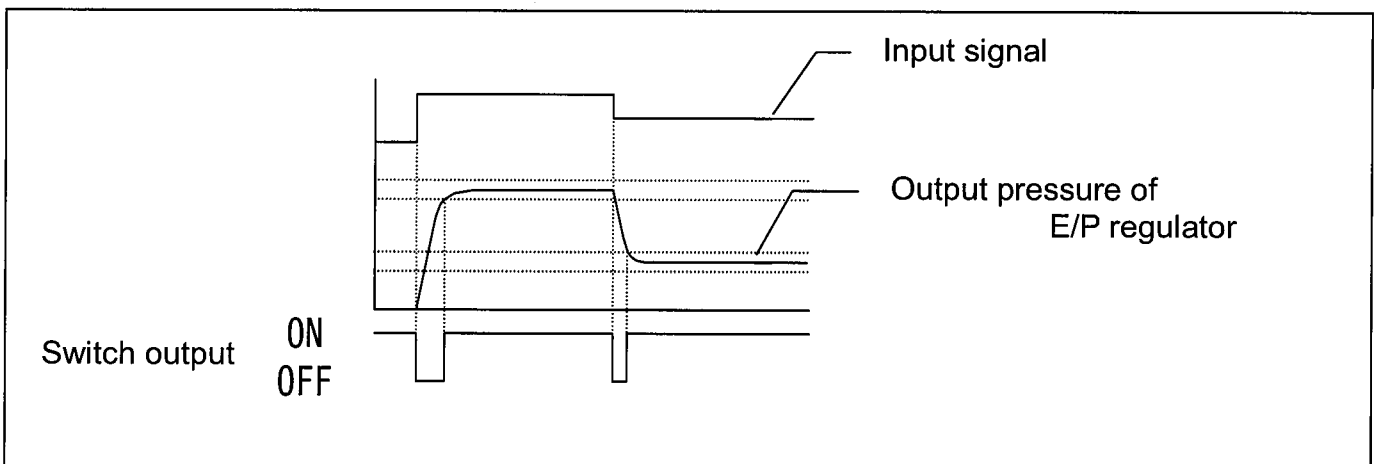

Reset function

Reset method

No	Key operation	LED Display
①	Unlock keys (refer to P9)	
②	Press the Δ and ∇ keys simultaneously for 3 seconds or more.	(Current) pressure is displayed
③		$rE5$ is displayed for approx. 1 second
④	The settings are reset and returned to the condition before power was applied. (Key locked)	

Reset content

Item	Reset content	Application model
F_1	0%F.S.	Current / Voltage input type
F_2	100%F.S.	Current / Voltage input type
P_1, P_2	100%F.S.	Switch output type

(Note) Gain (GL) is not reset.

Error Indication

Error name	LED display	Contents of error	Countermeasure
Over range of input signal	$rE1$	Input signal exceeds the rated value range.	Reduce input signal to within the rated range and restart the power supply.
System error	$rE2$	Reading or writing errors occurred in EEPROM.	Please execute "Initialize (refer to P15)" when the ITVX does not operate normally after reconnecting the power supply. Please contact SMC, when the ITVX does not operate normally after initialization.
	$rE3$	Reading and writing errors occurred in memory.	Please contact SMC when the ITVX does not operate normally after reconnecting the power supply.
Solenoid valve error	$rE4$	Solenoid valve failure	Replace the solenoid valve. For the replacement procedure contact SMC.
Over current error	$rE5$	Over current errors in switch output	Please install a load to give an output current of 80 mA or less.
Residual pressure error	$rE6$	Out of range error of "Zero clear"	Please operate "Zero clear" within the range of +/- 5% F.S. Please operate "Zero clear" after the secondary pressure of the ITVX has reached atmospheric.

Detail setting mode

No	Key operation and LED display
①	Unlock keys (refer to P9)
②	Press S-key for 2 seconds or more.
③	<p>(displayed alternately) Press S-key To "Gain" (P13)</p> <p>(displayed alternately) Press S-key To "Zero clear" (P14)</p> <p>(displayed alternately) Press S-key To "Initialize" (P15)</p>
④	In state of ③, press S-key for 2 seconds or more.
⑤	Return to (current) pressure display.
⑥	Lock keys (refer to P9)

Gain setting

Normal operation does not require the adjustment of gain.

The product can change the response time using this gain setting.

When the gain is changed to a larger value, the response will be faster, but there is a possibility that stability will be lost.

No	Key operation	LED Display
①	Unlock keys (refer to P9)	
②	Press S-key for 2 seconds or more, then go to detail setting mode.	
③	To "F01" by using the Δ and ▽ keys.	F01 ↔ 0L9 (displayed alternately)
④	Press S-key.	
⑤	Set the GAIN by using the Δ and ▽ keys.	0L9 (blink and change the most right digit)
⑥	Press S-key.	F01 ↔ 0L9 (displayed alternately)
⑦	Press S-key for 2 seconds or more, then go out from detail setting mode. (Select the menu with Δ or ▽ keys, then jump to another item.)	
⑧	Lock keys (refer to P9)	

Relation between setting of gain and response time

Response	Slow	\longleftrightarrow											Quick
Setting of GAIN	GL0	GL1	GL2	~	GL8	GL9	GLA	GLb	GLc	GLd	GLE	GLF	

(Note) Default : GL9

Zero clear

The display can be reset to zero by executing "Zero clear".

When "Zero clear" is executed with residual pressure in the secondary piping, the pressure is assumed to be zero. Please execute the operation of "Zero clear" with the supply pressure interrupted, and the piping of the secondary side removed.

No	Key operation	LED Display
①	Unlock keys (refer to P9)	
②	Press S-key for 2 seconds or more, then go to detail setting mode.	
③	To "F03" by using the Δ and ∇ keys.	F03 \leftrightarrow 0cL (displayed alternately)
④	Press S-key.	0cL displayed alternately
⑤	Press Δ and ∇ keys for 3 seconds or more. (press S-key to ③)	0cL is displayed
⑥	"Zero clear" is executed, after 3 seconds. (Release keys till less than 3 seconds to ④)	cLr is displayed for approx. 1 second.
⑦	Returns to the state immediately after turning on the power supply. (keys are locked)	

(Note) The adjustable range is within +/- 5% F.S from the state of the factory shipment. When outside of this range, ErE is displayed and "Zero clear" will not be executed.

Initialize

"Initialize" is a function to return all the settings that the internal control constant are included to an initial value. Please execute "initialize" only when the error is displayed and this product does not operate at all.

Please execute the "Reset" function, when you want to return the pressure setting and the switch setting to an initial value.

No	Key operation	LED Display
①	Unlock keys (refer to P9)	
②	Press S-key for 2 seconds or more, then go to detail setting mode.	
③	To "F99" by using the Δ and ∇ keys.	F99 \leftrightarrow 117 1 (displayed alternately)
④	Press S-key.	117 1 displayed alternately
⑤	Press Δ and ∇ keys for 3 seconds or more. (press S-key to ③)	117 1 is displayed
⑥	"Initialize" is executed, after 5 seconds. (Release keys till less than 5 seconds to ④)	Turning off for 1 second
⑦	Returns to the state immediately after turning on the power supply. (keys are locked)	

LED display

The range of the LED pressure display is different according to the unit of the display.

unit	MPa	kgf/cm ²	bar	psi
The range of the LED pressure display	0.00 to 3.60	0.0 to 36.0	0.0 to 36.0	0 to 522

(Note1) When the display exceeds the upper bound value, "HHH" is displayed.

(Note2) Set the minimum, maximum and switch pressures within the allowable range shown above.

(Note3) The unit cannot be changed.

Refer to the SMC website

(URL <http://www.smcworld.com>) for more information about troubleshooting.

This operation manual refers to all standard types and is partially applicable to special models.

A : Change of "Safety Instructions"
 B : P15 Addition note
 C : Change of " Min. press. (F_1) adjusting range"

SMC Corporation

4-14-1, Sotokanda, Chiyoda-ku, Tokyo 101-0021 JAPAN
 Tel: + 81 3 5207 8249 Fax: +81 3 5298 5362
 URL <http://www.smcworld.com>

 0120-837-838

Note: Specifications are subject to change without prior notice and any obligation on the part of the manufacturer.
 © 2012 SMC Corporation All Rights Reserved