



Operation Manual

Solenoid Valve

PRODUCT NAME

JSY1000/3000/5000 Series
(Plug-in)

MODEL/ Series

SMC Corporation

Contents

Contents	1
Safety Instructions	2,3
Design / Selection	4 to 6
Mounting	6
Piping	6
Wiring	6
Lubrication	7
Air Supply	7
Operating Environment	7,8
Maintenance	8
Specific Product Precautions	9 to 13
Valve Construction	14
Valve Replacement Parts: Pilot Valve	15
Manifold exploded view	16 to 30
Manifold option	31 to 33
Trouble shooting	34,35



Safety Instructions

These safety instructions are intended to prevent hazardous situations and/or equipment damage. These instructions indicate the level of potential hazard with the labels of “Caution,” “Warning” or “Danger.” They are all important notes for safety and must be followed in addition to International Standards (ISO/IEC)*1), and other safety regulations.

- *1) ISO 4414: Pneumatic fluid power -- General rules relating to systems.
- ISO 4413: Hydraulic fluid power -- General rules relating to systems.
- IEC 60204-1: Safety of machinery -- Electrical equipment of machines .(Part 1: General requirements)
- ISO 10218: Manipulating industrial robots -Safety.
- etc.

	Caution	Caution indicates a hazard with a low level of risk which, if not avoided, could result in minor or moderate injury.
	Warning	Warning indicates a hazard with a medium level of risk which, if not avoided, could result in death or serious injury.
	Danger	Danger indicates a hazard with a high level of risk which, if not avoided, will result in death or serious injury.

Warning

1. The compatibility of the product is the responsibility of the person who designs the equipment or decides its specifications.

Since the product specified here is used under various operating conditions, its compatibility with specific equipment must be decided by the person who designs the equipment or decides its specifications based on necessary analysis and test results.

The expected performance and safety assurance of the equipment will be the responsibility of the person who has determined its compatibility with the product.

This person should also continuously review all specifications of the product referring to its latest catalog information, with a view to giving due consideration to any possibility of equipment failure when configuring the equipment.

2. Only personnel with appropriate training should operate machinery and equipment.

The product specified here may become unsafe if handled incorrectly.

The assembly, operation and maintenance of machines or equipment including our products must be performed by an operator who is appropriately trained and experienced.

3. Do not service or attempt to remove product and machinery/equipment until safety is confirmed.

1. The inspection and maintenance of machinery/equipment should only be performed after measures to prevent falling or runaway of the driven objects have been confirmed.

2. When the product is to be removed, confirm that the safety measures as mentioned above are implemented and the power from any appropriate source is cut, and read and understand the specific product precautions of all relevant products carefully.

3. Before machinery/equipment is restarted, take measures to prevent unexpected operation and malfunction.

4. Contact SMC beforehand and take special consideration of safety measures if the product is to be used in any of the following conditions.

1. Conditions and environments outside of the given specifications, or use outdoors or in a place exposed to direct sunlight.

2. Installation on equipment in conjunction with atomic energy, railways, air navigation, space, shipping, vehicles, military, medical treatment, combustion and recreation, or equipment in contact with food and beverages, emergency stop circuits, clutch and brake circuits in press applications, safety equipment or other applications unsuitable for the standard specifications described in the product catalog.

3. An application which could have negative effects on people, property, or animals requiring special safety analysis.

4. Use in an interlock circuit, which requires the provision of double interlock for possible failure by using a mechanical protective function, and periodical checks to confirm proper operation.



Safety Instructions

Caution

The product is provided for use in manufacturing industries.

The product herein described is basically provided for peaceful use in manufacturing industries.

If considering using the product in other industries, consult SMC beforehand and exchange specifications or a contract if necessary.

If anything is unclear, contact your nearest sales branch.

Limited warranty and Disclaimer/Compliance Requirements

The product used is subject to the following "Limited warranty and Disclaimer" and "Compliance Requirements".

Read and accept them before using the product.

Limited warranty and Disclaimer

1. The warranty period of the product is 1 year in service or 1.5 years after the product is delivered, whichever is first. *2)

Also, the product may have specified durability, running distance or replacement parts. Please consult your nearest sales branch.

2. For any failure or damage reported within the warranty period which is clearly our responsibility, a replacement product or necessary parts will be provided.

This limited warranty applies only to our product independently, and not to any other damage incurred due to the failure of the product.

3. Prior to using SMC products, please read and understand the warranty terms and disclaimers noted in the specified catalog for the particular products.

*2) Vacuum pads are excluded from this 1 year warranty.

A vacuum pad is a consumable part, so it is warranted for a year after it is delivered.

Also, even within the warranty period, the wear of a product due to the use of the vacuum pad or failure due to the deterioration of rubber material are not covered by the limited warranty.

Compliance Requirements

1. The use of SMC products with production equipment for the manufacture of weapons of mass destruction (WMD) or any other weapon is strictly prohibited.

2. The exports of SMC products or technology from one country to another are governed by the relevant security laws and regulation of the countries involved in the transaction. Prior to the shipment of a SMC product to another country, assure that all local rules governing that export are known and followed.

Caution

SMC products are not intended for use as instruments for legal metrology.

Measurement instruments that SMC manufactures or sells have not been qualified by type approval tests relevant to the metrology (measurement) laws of each country.

Therefore, SMC products cannot be used for business or certification ordained by the metrology (measurement) laws of each country.



Precautions for 5 Port Solenoid Valve 1

Be sure to read before handling. Refer to main text for detailed precautions on every series.

Design / Selection

Warning

1. Confirm the specifications

Products represented in this instruction manual are designed only for use in compressed air systems (including vacuum).

Do not operate at pressures or temperatures, etc., beyond the range of specifications, as this can cause damage or malfunction.

We do not guarantee against any damage if the product is used outside of the specification range.

2. Actuator drive

When an actuator, such as a cylinder, is to be driven using a valve, take appropriate measures (such as the installation of a cover or the restricting of access to the product) to prevent potential danger caused by actuator operation.

3. Intermediate stops

For 3-position closed center, it is difficult to make a piston stop at the required position accurately due to the compressibility of air.

Furthermore, since valves and cylinders are not guaranteed for zero air leakage, it may not be possible to hold a stopped position for an extended period of time. Please contact SMC if it is necessary to hold a stopped position for an extended period of time.

4. Effect of back pressure when using a manifold.

Use caution when valves are used on a manifold because actuators may malfunction due to back pressure. For 3-position exhaust center valve of single acting cylinder, take appropriate measures to prevent the malfunction by using it with an individual exhaust manifold.

5. Holding pressure (including vacuum).

Since the valve are subject to air leakage, they cannot be used for applications such as holding pressure (including vacuum) in a pressure vessel.

6. Not suitable for use as an emergency shut-off valve, etc.

The valves listed in this instruction manual are not designed for safety applications such as an emergency shutoff valve. If the valves are used for the mentioned applications, additional safety measures should be adopted.

7. Release of residual pressure

For maintenance and inspection purposes install a system for releasing residual pressure. Especially in the case of 3-position closed center valve, ensure that the residual pressure between the valve and the cylinder is released.

8. Operation in a vacuum condition

When a valve is used for switching a vacuum, take measures to install a suction filter or similar to prevent external dust or other foreign matter from entering inside the valve.

In addition, at the time of vacuum adsorption, be sure to supply a constant supply of vacuum. Failure to do so may result in foreign matter sticking to the adsorption pad or air leakage, causing the workpiece to drop.

9. Regarding a vacuum switch valves and vacuum release valves

If a non-vacuum valve is installed in the middle of a piping system that contains a vacuum, the vacuum condition will not be maintained. Use a valve designed for use under vacuum conditions.

10. Double solenoid type

When using the double solenoid type for the first time, actuators may travel in an unexpected direction depending on the switching position of the valve.

Implement measures to prevent any danger from occurring when operating the actuator.

11. Ventilation

Provide ventilation when using a valve in a confined area, such as in a closed control panel. For example, install a ventilation opening, etc. in order to prevent pressure from increasing inside of the confined area and to release the heat generated by the valve.

12. Extended periods of continuous energization

- If a valve will be continuously energized for an extended period of time, the temperature of the valve will increase due to the heat generated by the coil assembly.

This will likely adversely affect the performance of the valve and any nearby peripheral equipment. Therefore, if the valve is to be energized for periods of longer than 30 minutes at a time or if during the hours of operation the energized period per day is longer than the de-energized period, we advise using a valve with specifications listed below.

- Pilot operated: A 0.4 W or lower valve, such as the SY/JSY series, or a valve with a power-saving circuit
- Direct operated: A continuous duty type valve such as the VK series or the VT series

If conflicting instructions are given in the "Specific Product Precautions" or on the "How to Order Valves" page, give them priority.

13. Do not disassemble the product of make any modifications, including additional machining.

Doing so may cause human injury and/or an accident.

14. Resumption after a long period of holding time

When resuming operation after a long period of holding time, there are cases in which, regardless of whether the product is in an ON or OFF state, there is a delay in the initial response time due to adhesion. Conducting several cycles of running-in operation will solve this problem. Please consider implementing this before resumption.



Precautions for 5 Port Solenoid Valve 2

Be sure to read before handling. Refer to main text for detailed precautions on every series.

Design / Selection

Caution

1. Precautions for 2-position double solenoid valves

If a double solenoid valve is operated with momentary energization, it should be energized for at least 0.1 second. However, depending on the piping conditions, the cylinder may malfunction even when the double solenoid valve is energized for 0.1 seconds or longer. In this case, energize the double solenoid valve until the cylinder is exhausted completely.

2. Leakage voltage

Take note that the leakage voltage will increase when a resistor is used in parallel with switching element or a C-R circuit (surge voltage suppressor) is used for protecting a switching device because of the passing leakage voltage through the C-R circuit.

The suppressor residual leakage voltage should be as 3% or less of the rated voltage.

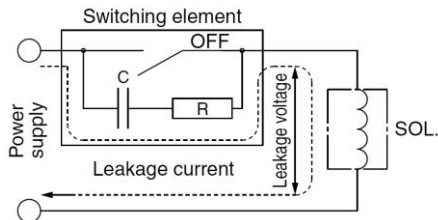

3. Surge voltage suppressor

1) The surge voltage suppressor built into the valve is intended to protect the output contacts so that the surge generated inside valve does not adversely affect the output contacts. Therefore, if an overvoltage or overcurrent is received from an external peripheral device, the surge voltage protection element inside the valve is overloaded, causing the element to break. In the worst case, the breakage causes the electric circuit to enter short-circuit status. If energizing continues while in this state, a large current flows. This may cause secondary damage to the output circuit, external peripheral device, or valve, and may also cause a fire. So, take appropriate protective measures, such as the installation of an overcurrent protection circuit in the power supply or a drive circuit to maintain a sufficient level of safety.

2) If a surge protection circuit contains nonstandard diodes, such as Zener diodes or varistor, a residual voltage that is in proportion to the protective circuit and the rated voltage will remain. Therefore, take into consideration the surge voltage protection of the controller. In the case of diodes, the residual voltage is approximately 1V.

4. Surge voltage intrusion

With non-polar type solenoid valves, at times of sudden interruption of the loading power supply, such as emergency shutdown, surge voltage intrusion may be generated from loading equipment with a large capacity (power consumption), and a solenoid valve in a de-energized state may switch over (see Figure 1). When installing a breaker circuit for the loading power supply, consider using a solenoid valve with polarity (with polarity protection diode), or install a surge absorption diode between the loading equipment COM line and the output equipment COM line (see Figure).

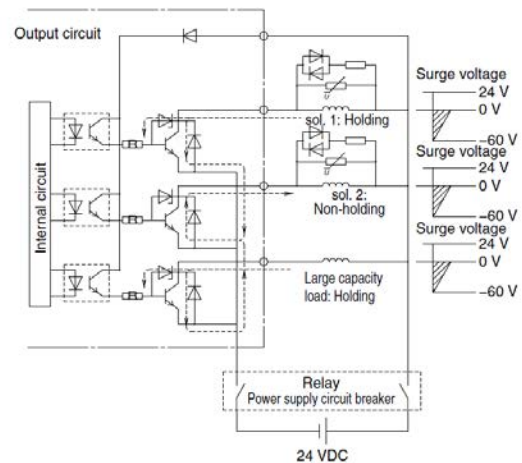

Figure 1. Surge intrusion circuit example (NPN outlet example)

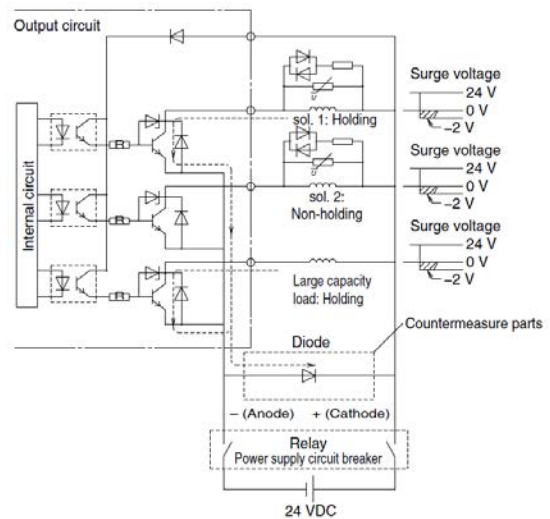

Figure 2. Surge intrusion countermeasure example (NPN outlet example)

5. Operation in low temperature conditions

It is possible to operate a valve in extreme temperatures, as low as -10°C . Take appropriate measures to avoid the freezing of drainage, moisture, etc., in low temperatures.



Precautions for 5 Port Solenoid Valve 3

Be sure to read before handling. Refer to main text for detailed precautions on every series.

Design / Selection

Caution

6. Operation for air blowing

When using a solenoid valve for air blowing, use an external pilot type. Use caution because the pressure drop caused by the air blowing can have an effect on the internal pilot type valve when internal pilot type valves and external pilot type valves are used on the same manifold.

Additionally, when compressed air within the pressure range of the established specifications is supplied to the external pilot type valve's port, and a double solenoid valve is used for air blowing, the solenoids should be energized when air is being blown.

7. Mounting orientation

Mounting orientation is free.

8. Initial lubrication of main valve

The initial lubricant (Grease) has already been applied to the main valve.

Please consult with SMC, as there are some standard valve products that use fluorine grease for food processing equipment (NSF H-1).

9. For the pilot EXH. (PE) port

If the solenoid valve and the manifold's pilot EXH (PE) port is restricted extremely or blocked, abnormal operation of the solenoid valve may occur.

Mounting

Warning

1. Operation manual

Install the products and operate them only after reading the operation manual carefully and understanding its contents. Also, keep the manual where it can be referred to as necessary.

2. Ensure sufficient space for maintenance activities.

When installing the products, allow access for maintenance and inspection.

3. Tighten threads with the proper tightening torque.

When installing the products, follow the listed torque specifications.

4. If air leakage increases or equipment does not operated properly, stop operation.

Check mounting conditions when air and power supplies are connected. Initial function and leakage tests should be performed after installation.

5. Painting and coating

Warnings or specifications printed or affixed to the product should not be erased, removed or covered up. Please consult with SMC before applying paint to resinous parts, as this may have an adverse effect due to the solvent in the paint.

Piping

Caution

1. Refer to the Fittings and Tubing Precautions for handling one-touch fittings.

2. Closed center

For closed center, check the piping to prevent air leakage from the piping between the valve and the cylinder.

3. Piping to products

When piping to a product, avoid mistakes regarding the supply port, etc.

Wiring

Warning

1. The solenoid valve is an electrical product. For safety, install an appropriate fuse and circuit breaker before use.

Caution

1. Polarity

When connecting power to a solenoid valve with a DC specification and equipped with a light or surge voltage suppressor, check for polarity. If there is polarity, take note of the following.

No diode to protect polarity.

If a mistake is made regarding the polarity, damage may occur to the diode in the valve, the switching element in a control device or power supply equipment, etc.

With diode to protect polarity.

If polarity connection is wrong, the valve will not operate.

2. Applied voltage

When electric power is connected to a solenoid valve, be careful to apply the proper voltage. Improper voltage may cause malfunction or coil damage.

3. Check the connections.

Check if the connections are correct after completing all wiring.



Precautions for 5 Port Solenoid Valve 4

Be sure to read before handling. Refer to main text for detailed precautions on every series.

Lubrication

Warning

1. Lubrication

- 1) The valve has been lubricated for life by the factory and does not require any further.
- 2) If a lubricant is used in the system, use class 1 turbine oil (no additives), ISO VG32. For details about lubricant manufacturers' brands, refer to the SMC website. Additionally, please contact SMC for details about class 2 turbine oil (with additives) ISO VG32. Once lubricant is utilized within the system, since the original lubricant applied within the product during manufacturing will be washed away, please continue to supply lubrication to the system. Without continued lubrication, malfunctions could occur. If turbine oil is used, refer to the Safety Data Sheet (SDS) of the oil.

2. Lubrication amount

If the lubrication amount is excessive, the oil may accumulate inside the pilot valve, causing malfunction or response delay. So, do not apply a large amount of oil. When a large amount of oil needs to be applied, use an external pilot type to put the supply air on the pilot valve side in the non-lube state. This prevents the accumulation of oil inside the pilot valve.

Air Supply

Warning

1. Type of fluids

Please consult with SMC when using the product in applications other than compressed air.

2. When there is a large amount of drainage.

Compressed air containing a large amount of drainage can cause malfunction of pneumatic equipment. An air dryer or water separator should be installed upstream from filters.

3. Drain flushing

If condensation in the drain bowl is not emptied on a regular basis, the bowl will overflow and allow the condensation to enter the compressed air lines. It causes malfunction of pneumatic equipment. If the drain bowl is difficult to check and remove, installation of a drain bowl with an auto drain option is recommended.

For compressed air quality, refer to SMC's Best Pneumatics catalog.

4. Use clean air

Do not use compressed air that contains chemicals, synthetic oils including organic solvents, salt or corrosive gasses, etc., as it can cause damage or malfunction.

Caution

1. **When extremely dry air is used as the fluid, degradation of the lubrication properties inside the equipment may occur, resulting in reduced reliability (or reduced service life) of the equipment. Please consult with SMC.**

2. **Install an air filter.**

Install an air filter upstream near the valve. Select an air filter with a filtration size of 5 µm or smaller.

3. **Take measures to ensure air quality, such as by installing an aftercooler, air dryer, or water separator.**

Compressed air that contains a large amount of drainage can cause the malfunction of pneumatic equipment, such as valves. Therefore, take appropriate measures to ensure air quality, such as by providing an aftercooler, air dryer, or water separator.

4. **If an excessive amount of carbon powder is present, install a mist separator on the upstream side of the valve.**

If excessive carbon dust is generated by the compressor, it may adhere to the inside of a valve and cause it to malfunction.

For compressed air quality, refer to the SMC Best Pneumatics catalog.

Operating Environment

Warning

1. Do not use in an atmosphere containing corrosive gases, chemicals, sea water, water, water steam, or where there is direct contact with any of these.
2. Products with IP65 and IP67 enclosures (based on IEC60529) are protected against dust and water. However, these products cannot be used in water.
3. Products compliant with IP65 and IP67 satisfy the product specifications when mounted properly. Be sure to read the precautions for each product.
4. Do not use in an environment where flammable gas or explosive gas exists. Usage may cause a fire or explosion. The products do not have an explosion proof construction.
5. Do not use in a place subject to heavy vibration and/or shock.
6. The valve should not be exposed to prolonged sunlight. Use a protective cover. Note that the valve is not for outdoor use.
7. Remove any sources of excessive heat.
8. If it is used in an environment where there is possible contact with oil, weld spatter, etc., exercise preventive measures.
9. When the solenoid valve is mounted in a control panel or it's energized for a long period of time, make sure the ambient temperature is within the specifications of the valve.



Precautions for 5 Port Solenoid Valve 5

Be sure to read before handling. Refer to main text for detailed precautions on every series.

Operating Environment

⚠ Caution

1. Temperature of ambient environment

Use the valve within the range of the ambient temperature specification of each valve. In addition, pay attention when using the valve in environments where the temperature changes drastically.

2. Humidity of ambient environment

- When using the valve in environments with low humidity, take measures to prevent static.
- If the humidity rises, take measures to prevent the adhesion of water droplets on the valve.

Maintenance

⚠ Warning

1. Perform maintenance and inspection according to the procedures indicated in the operation manual.

If handled improperly, human injury and/or malfunction or damage of machinery and equipment may occur.

2. Removal of equipment, and supply/exhaust of compressed air

Before components are removed, first confirm that measures are in place to prevent workpieces from dropping, run-away equipment, etc. Then, cut off the supply air and electric power, and exhaust all air pressure from the system using the residual pressure release function.

For the 3-position closed center, exhaust the residual pressure between the valve and the cylinder. When the equipment is operated after remounting or replacement, first confirm that measures are in place to prevent the lurching of actuators, etc. Then, confirm that the equipment is operating normally. In particular, when a 2-position double solenoid valve is used, releasing residual pressure rapidly may cause the spool valve to malfunction, depending on the piping conditions, or the connected actuator to operate.

3. Low-frequency operation

Valves should be operated at least once every 30 days to prevent malfunction. (Use caution regarding the air supply.)

4. Manual override

When a manual override is operated, connected equipment will be actuated.

Operate only after safety is confirmed.

5. If the volume of air leakage increases or the valve does not operate normally, do not use the valve.

Perform periodic maintenance on the valve to confirm the operating condition and check for any air leakage.

⚠ Caution

1. Drain flushing

Remove drainage from the air filters regularly.

2. Lubrication

In the case of rubber seals, once lubrication has been started, it must be continued.

Use class 1 turbine oil (with no additives), VG32. If other lubricant oil is used, it may cause a malfunction. Please contact SMC for information on the suggested class 2 turbine oil (with additives), VG32.

3. Manual override operation

When switching a double solenoid valve via the manual override operation, instantaneous operation may cause the malfunction of the cylinder. It is recommended that the manual override be held until the cylinder reaches the stroke end position.



JSY1000/3000/5000 series Specific Product Precautions 1

Be sure to read this before handling.

Environment

Warning

1. Products compliant with IP67 enclosures (based on IEC60529) are protected against dust and water, however, these products cannot be used in water. If using in an environment that is exposed to water and dust splashes, take measures such as using a protective cover.
2. When using built-in silencer type manifold with an IP67 enclosure, keep the exhaust port of the silencer from coming in direct contact with water or other liquids.

Valve Mounting

Caution

Mount it so that there is no slippage or deformation in gaskets, and tighten with the tightening torque as shown on the right.

Series	Thread size	Tightening torque
JSY1000	M1.4	0.06 N·m
JSY3000	M2	0.16 N·m
JSY5000	M3	0.8 N·m

Manual Override

Warning

Regardless of an electric signal for the valve, the manual override is used for switching the main valve. Connected actuator is started by manual operation. Use the manual override after confirming that there is no danger.

Non-locking push type

Push down on the manual override button until it stops.

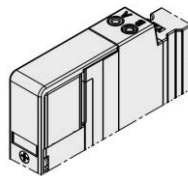

Push-turn locking slotted type [D type]

Push down on the manual override with a small flat head screwdriver until it stops, and then turn it 90° clockwise. The manual override is then locked. To release it, turn it counterclockwise. If it is not turned, it can be operated the same way as the non-locking push type.

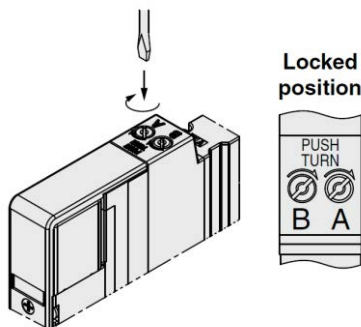

Push-turn locking lever type [E type] (Only for the JSY3000/5000)

Push down on the manual override by finger until it stops, and then turn it 60° clockwise. The manual override is then locked. To release it, turn it counterclockwise. If it is not turned, it can be operated the same way as the non-locking push type.

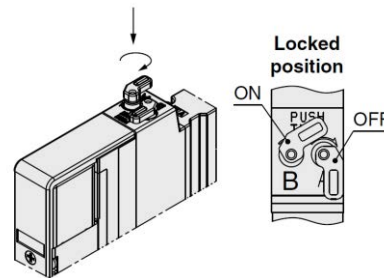

Carefully check the manual override projection amount. Max. (at OFF): 3.7 mm

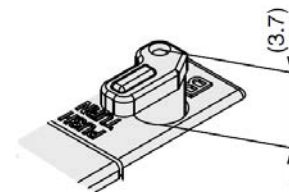

Caution

Do not apply excessive torque when turning the manual override. [0.1 N·m]
When locking the manual override, be sure to push it down before turning. Turning without first pushing it down can cause damage to the manual override and other trouble such as air leakage, etc.

Used as a 3-Port Valve

Caution

In case of using a 5-port valve as a 3-port valve

The JSY1000/3000/5000 series can be used as normally closed (N.C.) or normally open (N.O.) 3-port port valves by closing one of the cylinder ports 4(A) or 2(B) with a plug. However, they should be used with the exhaust ports kept open. Use them when a double solenoid type 3-port valve is required.

Plug position		B port	A port
Type of actuation		N.C.	N.O.
Number of solenoids	Single	(A)4 2(B) (EA)5 1 3(EB) (P)	(A)4 2(B) (EA)5 1 3(EB) (P)
	Double	(A)4 2(B) (EA)5 1 3(EB) (P)	(A)4 2(B) (EA)5 1 3(EB) (P)



JSY1000/3000/5000 series Specific Product Precautions 2

Be sure to read this before handling.

Light/Surge Voltage Suppressor

Caution

■ Polar type

Positive common

Single solenoid

Light/surge voltage suppressor (□Z)

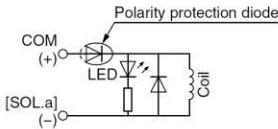

Negative common

Single solenoid

Light/surge voltage suppressor (□NZ)

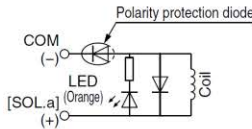

Positive common

Double solenoid, 3-position, 4-position

Light/surge voltage suppressor (□Z)

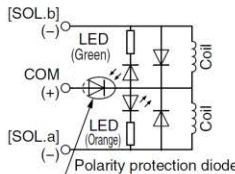

Negative common

Double solenoid, 3-position, 4-position

Light/surge voltage suppressor (□NZ)

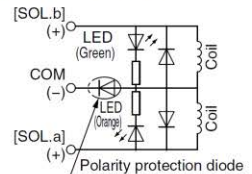

■ Non-polar type

With light/surge voltage suppressor (□U)

Single solenoid

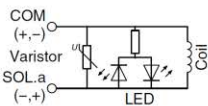

Double solenoid

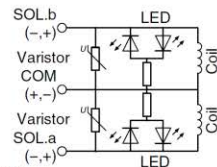

* Non-polar type is not available for the JSY1000.

■ With power saving circuit

(JSY3000/5000 series products are made to order.)

Power consumption is decreased to approx. 1/2.5 to 1/4 of the amount consumed at startup by reducing the wattage required to hold the valve in an energized state. (Effective energizing time is over 67 ms at 24 VDC.)

<Standard>

Electric circuit diagram
(With power saving circuit)
In the case of single solenoid

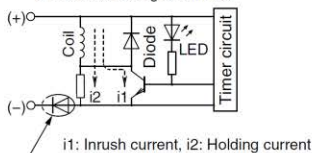

The circuit shown to the left reduces the power consumption for holding in order to save energy. Refer to the electrical power waveform as shown below.

<Electrical power waveform with power saving circuit>

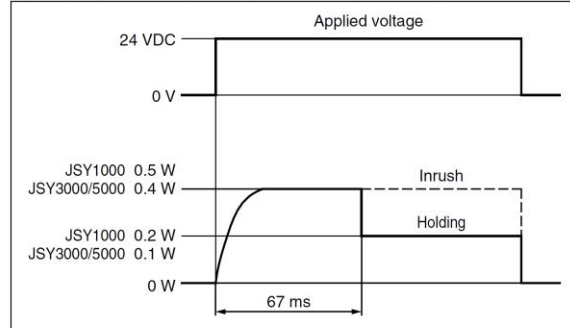

Since the voltage will drop by approx. 0.5 V due to the transistor, pay attention to the allowable voltage fluctuation. (For details, refer to the solenoid specifications of each type of valve.)

Residual voltage of the surge voltage suppressor

* If a varistor or diode surge voltage suppressor is used, there is some residual voltage to the protection element and rated voltage. Therefore, refer to the below table and pay attention to the surge voltage protection on the controller side. Also, since the response time does change, refer to the valve specifications.

Residual Voltage

Surge voltage suppressor	24 VDC
Z	Approx. 1 V
U	Approx. 47 V

Continuous Duty

Caution

If a valve is energized continuously for long periods of time, the rise in temperature due to heat-up of the coil assembly may cause a decline in solenoid valve performance, reduce service life, or have adverse effects on peripheral equipment. If the valve is energized continuously for long periods of time, be sure to use a valve with power saving circuit. In particular, if three or more adjacent stations on the manifold are energized simultaneously for extended periods of time or if the valves on A side and B side are energized simultaneously for long periods of time, take special care as the temperature rise will be greater.

Energization of a 2-Position Double Solenoid Valve

Caution

To avoid operation failure, do not energize the A side and B side of 2-position double solenoid valve at the same time.



JSY1000/3000/5000 series Specific Product Precautions 3

Be sure to read this before handling.

Countermeasure for Surge Voltage Intrusion

Caution

With non-polar type valves(JSY3000/5000 series), at times of sudden interruption of the loading power supply, such as emergency shutdown, surge voltage intrusion may be generated from loading equipment with a large capacity (power consumption), and the valve in a de-energized state may switch over (see Figure 1).
When installing a breaker circuit for the loading power supply, consider using a valve with polarity (with polarity protection diode), or install a surge absorption diode between the loading equipment COM line and the output equipment COM line (see Figure 2).

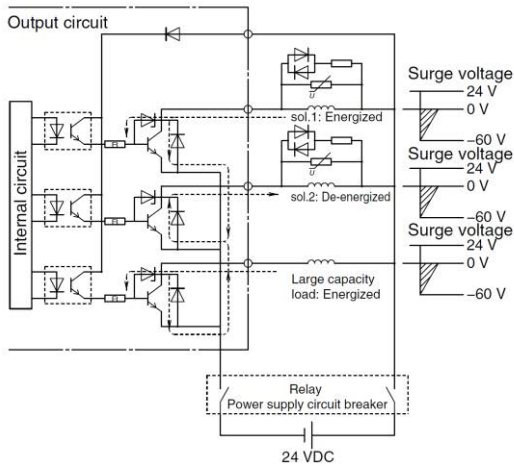

Figure 1. Surge intrusion circuit example (NPN outlet example) (24 VDC)

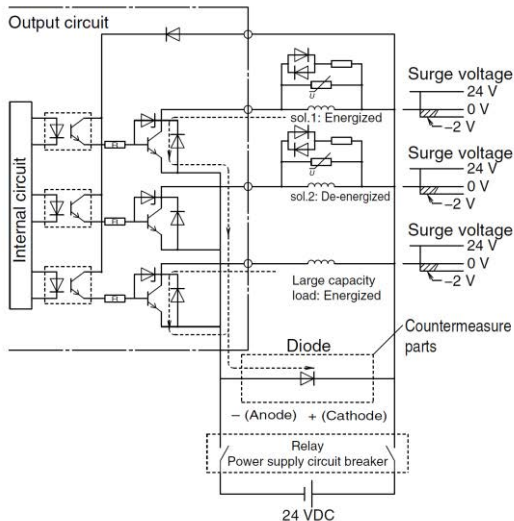
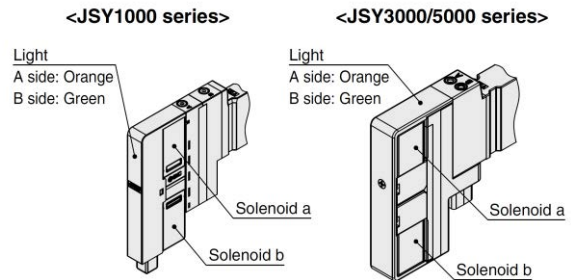

Figure 2. Surge intrusion circuit example (NPN outlet example) (24 VDC)

Light Indication

Caution

When equipped with indicator light and surge voltage suppressor, the light window turns orange when solenoid a is energized, and it turns green when solenoid b is energized.



Changing Connector Entry Direction

Caution

Connector direction for electrical entry of D-sub connector and flat ribbon cable <IP40> can be changed. If the directional change is required, slide the lever on the side of the connector block to the FREE position, and then change the direction as shown in the figure. Also, before connecting the connector, be sure to return the lever to the LOCK position. (If the lever is difficult to slide, move the connector a little bit to make it easier to slide the lever.)
If an excessive force is applied on the connector in the LOCK position, the connector block may be damaged. Also, using in such a way that the connector floats in the FREE position, it may cause the lead wire etc., to break.
* Direction cannot be changed for D-sub connector <IP67> or compact type.

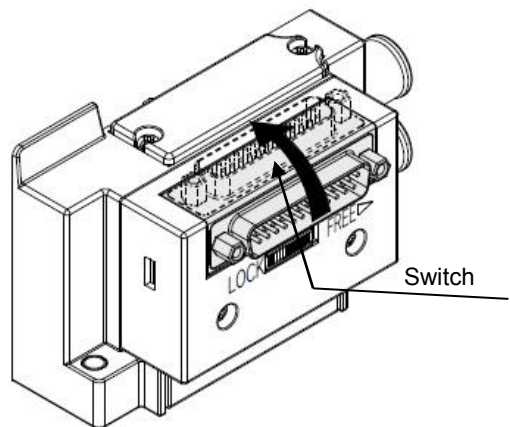



JSY1000/3000/5000 series

Specific Product Precautions 4

Be sure to read this before handling.

How to Order Manifolds

⚠ Caution

The letter “S” is indicated on manifold blocks for the JSY series as shown below. This indication refers to the type of substrate (single wiring) inside the manifold blocks. When there is no symbol, double wiring is used. When the manifold specification sheet does not include a wiring specification, all stations will be double wiring specification. In this case, single and double solenoid valves can be mounted in any position, but when a single valve is used, there will be an unused control signal. To avoid this, indicate positions of manifold blocks for single wiring specification and double wiring specification on a manifold specification sheet. (Note that double, 3-or 4-position valves cannot be used for manifolds blocks with single wiring specification S.)

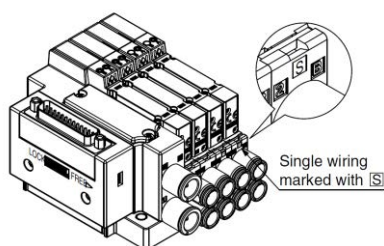

Substrate inside Manifolds

⚠ Caution

The substrate inside of manifolds cannot be taken apart. Attempting to do so may damage parts.

Fixation of DIN Rail Mounting Type Manifolds

⚠ Caution

1. When the manifold is fixed with bolts on a mounting surface etc., it can be operated just by fixing on both ends of the DIN rail if the bottom surface of the DIN rail is entirely in contact with the mounting surface when mounted horizontally. However, if it is used with other mounting or with side or reverse mounting, fix the DIN rail with bolts at regular intervals. As a guide, insert bolts in 2 locations for 2-5 stations, 3 locations for 6-10 stations, 4 locations for 11-15 stations, 5 locations for 16-20 stations and 6 locations for 21-24 stations.
2. When using the manifold with DIN rail in an environment where any vibration or impact is applied to it, the DIN rail itself may be broken. In particular, if the installation surface vibrates when mounting the manifold on the wall or if a load is directly applied to the manifold, the DIN rail may be broken, causing the manifold to drop. When any vibration, impact, or load is applied to the manifold, be sure to use the direct mounting manifold.

How to Replace One-touch Fittings

⚠ Caution

By replacing One-touch fittings of manifold base, it is possible to change the connection diameter of the 4(A), 2(B), 1(P), 3/5(E) ports. When replacing the One-touch fittings, remove the clip or the plate before pulling the One-touch fittings off. Mount the One-touch fittings by following the removal procedure in reverse. Use caution as it may cause air leakage if the clip and the plate are not inserted securely enough when they are switched.

■ Connector connecting base

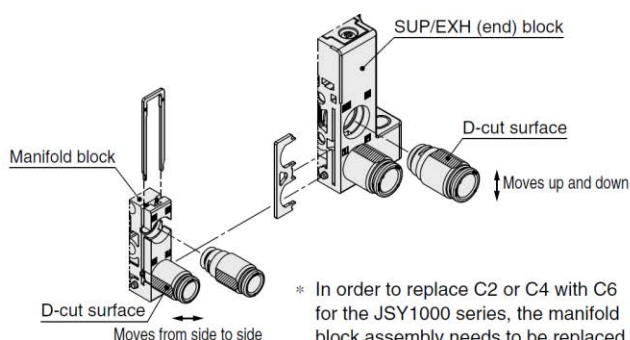

- * In order to replace C2 or C4 with C6 for the JSY1000 series, the manifold block assembly needs to be replaced. Please select the manifold block assembly on page 28 .
- * Refer to page 30 for One-touch fitting, clip, and port plate part numbers.

<Assembly method>

• SUP/EXH (end) block

Fitting direction is specified when the fittings below are used. Assemble the fitting so that the D-cut surfaces of the fitting face up and down.

Fitting part no.: KQSY30-C8-X1336 (JSY1000)
KQSY50-C12-X1336 (JSY5000)

• Manifold block

Assemble the fitting so that the D-cut surfaces of the fitting face sideways.

Fitting part no.: KQSY10-C4-X1336 (JSY1000)
KQSY11-C6-X1336 (JSY1000)
KQSY30-C8-X1336 (JSY3000)
KQSY50-C12-X1336 (JSY5000)



JSY1000/3000/5000 series

Specific Product Precautions 5

Be sure to read this before handling.

Other Tube Brands

⚠ Caution

When using other than SMC brand tube, confirm that the following specifications are satisfied with respect to the tube outside diameter tolerance.

- | | |
|----------------------|---------------------------------------|
| 1) Nylon tube | within ± 0.1 mm |
| 2) Soft nylon tube | within ± 0.1 mm |
| 3) Polyurethane tube | within $+0.15$ mm
within -0.2 mm |

Do not use tube which do not meet these outside diameter tolerances. It may not be possible to connect them, or they may cause other trouble, such as air leakage or the tube pulling out after connection.

One-touch Fittings

⚠ Caution

■ Tube attachment/detachment for One-touch fittings

1) Tube attachment

- Take a tube having no flaws on its periphery and cut it off at a right angle. When cutting the tube, use tube cutters TK-1, 2 or 3. Do not use pliers, nippers or scissors, etc. If cutting is done with tools other than tube cutters, the tube may be cut diagonally or become flattened, etc., making a secure installation impossible, and causing problems such as the tube pulling out after installation or air leakage. Allow some extra length in the tube.
- Grasp the tube and push it in slowly, inserting it securely all the way into the fitting.
- After inserting the tube, pull on it lightly to confirm that it will not come out. If it is not installed securely all the way into the fitting, this can cause problems such as air leakage or the tube pulling out.

2) Tube detachment

Use the release tool when the removal of tube is difficult due to the tube size. Refer to page 30 for releasing tools.

- Push in the release button sufficiently, pushing its collar equally around the circumference.
- Pull out the tube while holding down the release button so that it does not come out. If the release button is not pressed down sufficiently, there will be increased bite on the tube and it will become more difficult to pull it out.
- When the removed tube is to be used again, cut off the portion which has been chewed before reusing it. If the chewed portion of the tube is used as is, this can cause trouble such as air leakage or difficulty in removing the tube.

Fixing Method of JSY1000 Series Clamp Bracket

⚠ Caution

The clamp bracket fixing method for the JSY1000 series is different depending on wiring.

■ Wiring

<For D-sub connector/Flat ribbon cable/Spring type terminal block box/Lead wire/EX260/EX120>

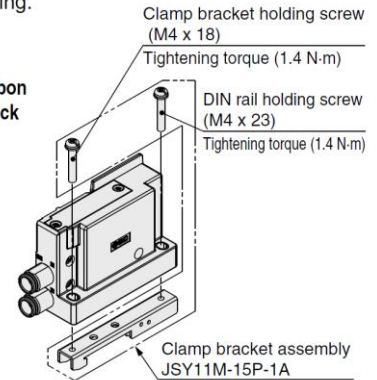

- * When the DIN rail is not accommodated in the clamp bracket, loosen the DIN rail holding screw once and insert the DIN rail.

<For Terminal block box/EX600/EX250>

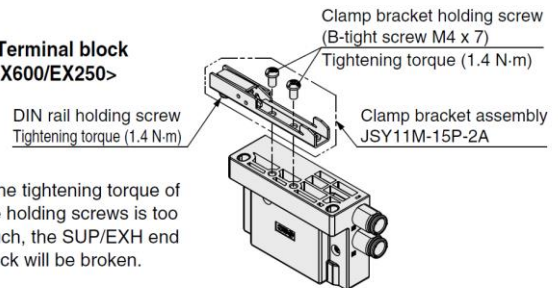

- * If the tightening torque of the holding screws is too much, the SUP/EXH end block will be broken.

Installation

⚠ Caution

Even though the inlet pressure is within the operating pressure range, when the piping diameter is restricted due to size reduction of supply port (P), the flow will be insufficient. In this case, the valve does not switch completely and the cylinder may malfunction.

Valve Construction

Rubber Seal

2-position single

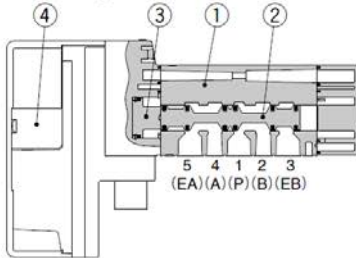

2-position single

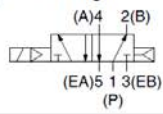

2-position double

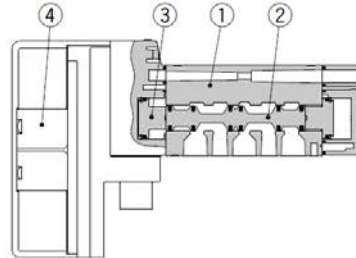

2-position double

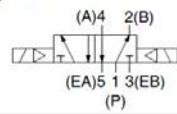

3-position closed center/exhaust center/pressure center

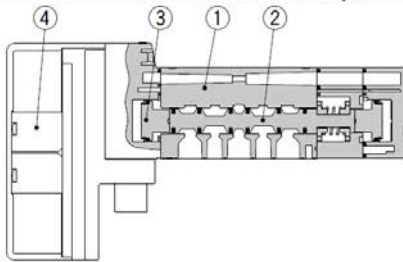

3-position closed center

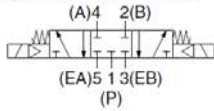

3-position exhaust center

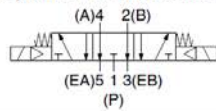

3-position pressure center

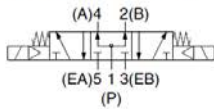

4-position dual 3-port valve

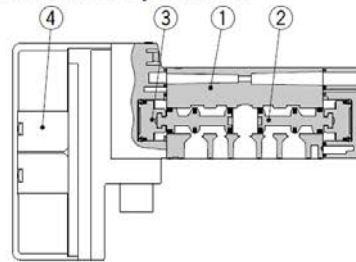

4-position dual 3-port valve
N.C. valve x 2 pcs.

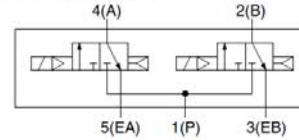

N.O. valve x 2 pcs.

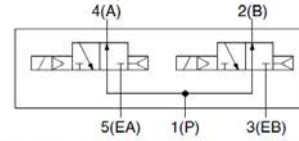

N.C. valve, N.O. valve 1 pc. of each

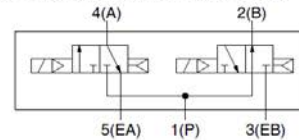

Component Parts

No.	Description	Material
1	Body	Aluminum die-casted
2	Spool valve	Aluminum/HNBR (4-position solenoid valve: Resin/HNBR)
3	Piston	Resin
4	Pilot valve assembly	—

Valve Replacement Parts: Pilot Valve

How to Order Pilot Valves (With a gasket and two mounting screws)*3

V112 - 5 A

Coil type

Nil	Standard
T	With power saving circuit (Made to Order)

Rated voltage

5	24 VDC
---	--------

⚠ Caution

1. The coil specification and voltage (including light/surge voltage suppressor) cannot be changed by changing the pilot valve assembly.
2. When selecting the standard coil type, it is not possible to change to the power saving circuit type.
3. Replacement pilot valve for the JSY3000/5000

How to replace pilot valves

Pilot cover

Series	Part no.
JSY3000	SY30V-25AS
JSY5000	SY50V-25A

* Pilot cover x 1 + B tight flat head screw x 1

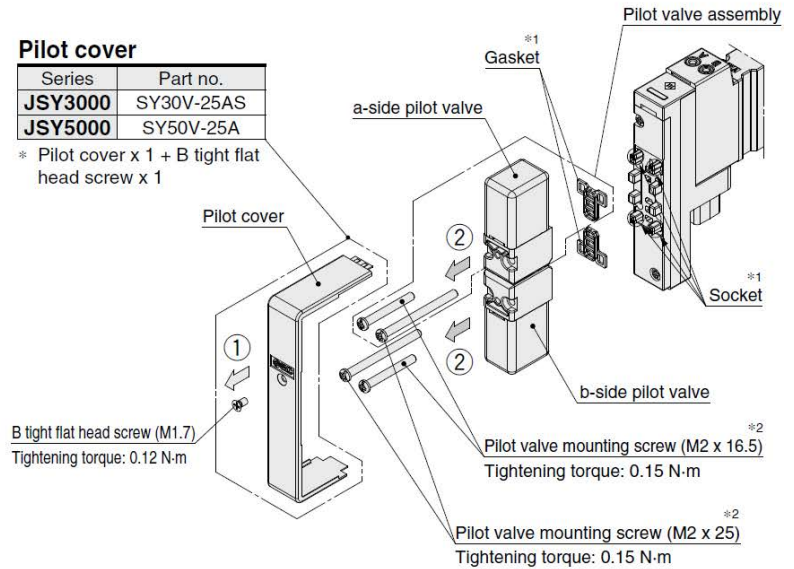

- Loosen B tight flat head screw to remove the pilot cover in the direction indicated by the arrow ①.
- Remove the pilot valve mounting screws.
- Remove the pilot valve in the direction indicated by the arrow ②.

* Assemble by following the removal procedure in reverse.

*1 Ensure the gasket is mounted, and take care not to bend the socket.

*2 Be noted for mounting that there are two types of lengths for the pilot valve mounting screws.

*3 The pilot valve of the JSY1000 cannot be removed. This is irreplaceable.

Wiring

D-sub Connector/Flat Ribbon Cable (IP40/Connector Entry Direction Adjustable)

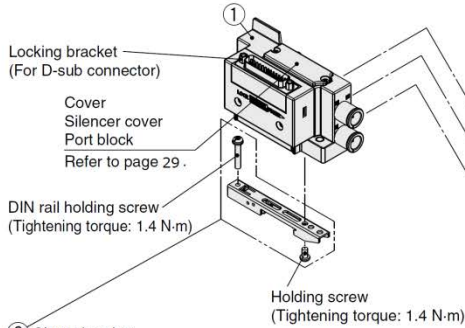

- ② Clamp bracket
It is mounted only for the DIN rail mounting type.
The holding screw of the clamp bracket is tightened at one point (for the JSY3000).
* The clamp bracket fixing method for the JSY1000 is different depending on wiring. Refer to page 13.

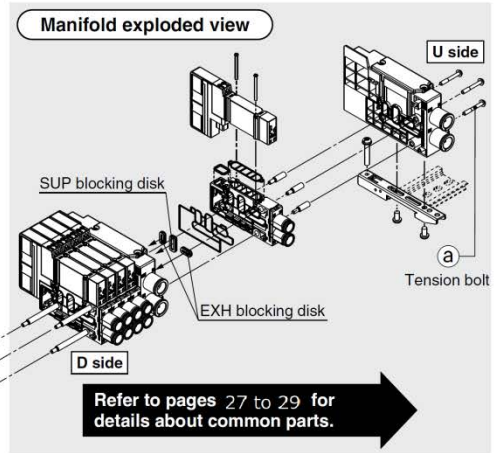

Manifold Parts Nos.

① SUP/EXH block assembly

JSY **3** 1M-1P-**3** A **1** - C**10**

Series

1	JSY1000
3	JSY3000
5	JSY5000

Mounting

Nil	Direct mounting
D0	DIN rail mounting (Without DIN rail)

SUP/EXH block assembly

3	D-sub connector (25 pins)
4	Flat ribbon cable (26 pins)
5	Flat ribbon cable (20 pins)
6	Flat ribbon cable (10 pins)

P, E port size (One-touch fittings)

Symbol	P, E port	JSY1000	JSY3000	JSY5000
C8	ø8 One-touch fitting	●	—	—
C10	ø10 One-touch fitting	—	●	—
C12	ø12 One-touch fitting	—	—	●
00*1	Plug	●	●	●

*1 Can be selected when the pilot, silencer type symbol is "Nil" or "S."
Not available for "R" type.

Pilot, Silencer type

Symbol	Pilot type		
	Internal	External (Made to Order)	Built-in silencer
Nil	●	—	—
S	●	—	●
R	—	●	—

* 3/5(E) port is plugged for the built-in silencer type.

Connector entry direction

1	Upward
2	Lateral

SUP/EXH block assembly (D side) accessories and the number of accessories

Accessories	JSY1000 JSY3000	JSY5000
② Tension bolt	None*1	3 pcs.

*1 Since the nuts are embedded in the SUP/EXH block.

② Clamp bracket

Series	Part no.
JSY1000	JSY11M-15P-1A
JSY3000	SY30M-15-1A
JSY5000	SY50M-15-1A

* Part number is for one piece.

Wiring

D-sub Connector (IP67)

(For JSY3000/5000)

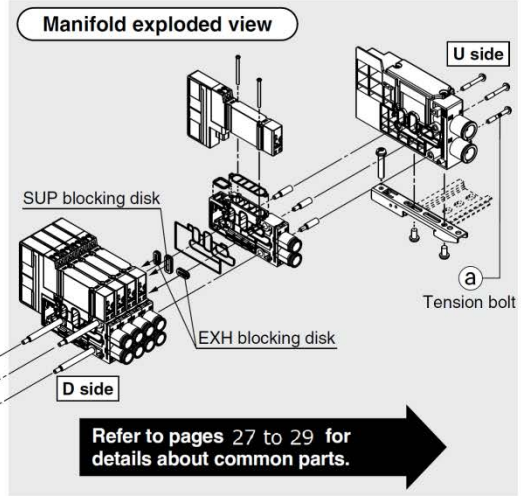
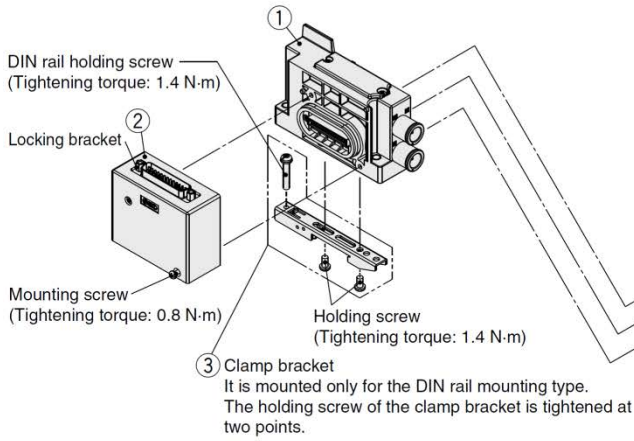

Manifold Parts Nos.

① SUP/EXH block assembly

JSY **3** 1M-1P-1A **C10**

• Series

3	JSY3000
5	JSY5000

• Mounting

Nil	Direct mounting
D0	DIN rail mounting (Without DIN rail)

• Pilot, Silencer type

Symbol	Pilot type		Built-in silencer
	Internal	External (Made to Order)	
Nil	●	—	—
S	●	—	●
R	—	●	—

* 3/5(E) port is plugged for the built-in silencer type.

• P, E port size (One-touch fittings)

Symbol	P, E port	JSY3000	JSY5000
C10	ø10 One-touch fitting	●	—
C12	ø12 One-touch fitting	—	●
00*1	Plug	●	●

*1 Can be selected when the pilot, silencer type symbol is "Nil" or "S." Not available for "R" type.

SUP/EXH block assembly (D side) accessories and the number of accessories

Accessories	JSY3000	JSY5000
a Tension bolt	None*1	3 pcs.

*1 Since the nuts are embedded in the SUP/EXH block.

② D-sub connector block <for IP67>

Part no.	Connector entry direction
SY30M-14-9A1	Upward
SY30M-14-9A2	Lateral

③ Clamp bracket

Series	Part no.
JSY3000	SY30M-15-1A
JSY5000	SY50M-15-1A

* Part number is for one piece.

Wiring

D-sub Connector/Flat Ribbon Cable (IP20/Compact Type) (For JSY1000/3000)

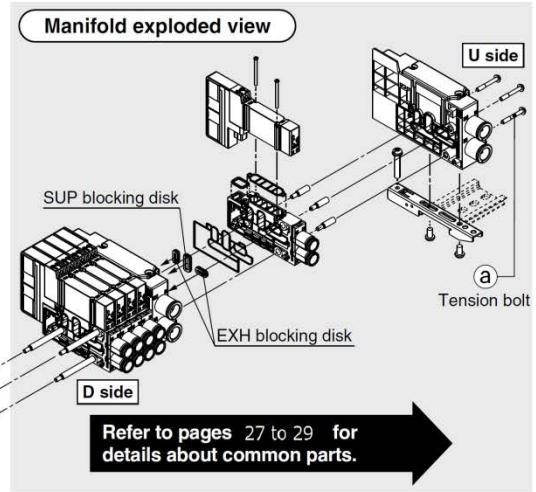
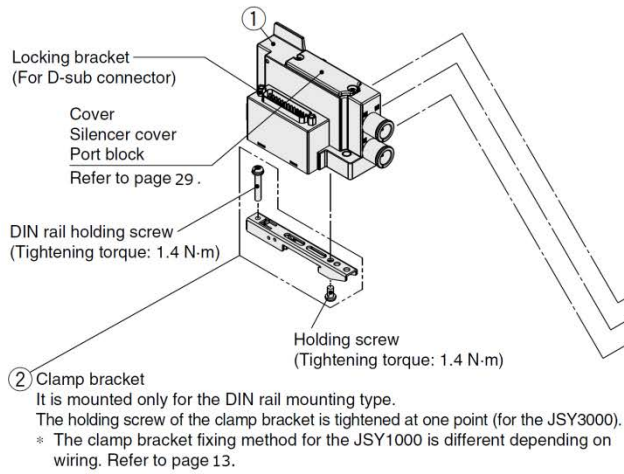

Manifold Parts Nos.

① SUP/EXH block assembly

JSY **3** 1M-1P-9 A **1** - C10

Series

1	JSY1000
3	JSY3000

Mounting

Nil	Direct mounting
D0	DIN rail mounting (Without DIN rail)

SUP/EXH block assembly

9	D-sub connector (25 pins)
10	Flat ribbon cable (26 pins)
11	Flat ribbon cable (20 pins)
12	Flat ribbon cable (10 pins)

P, E port size (One-touch fittings)

Symbol	P, E port	JSY1000	JSY3000
C8	ø8 One-touch fitting	●	—
C10	ø10 One-touch fitting	—	●
00*1	Plug	●	●

*1 Can be selected when the pilot, silencer type symbol is "Nil" or "S." Not available for "R" type.

Pilot, Silencer type

Symbol	Pilot type		Built-in silencer
	Internal	External (Made to Order)	
Nil	●	—	—
S	●	—	●
R	—	●	—

* 3/5(E) port is plugged for the built-in silencer type.

Connector entry direction

1	Upward
2	Lateral

② Clamp bracket

Series	Part no.
JSY1000	JSY11M-15P-1A
JSY3000	SY30M-15-1A

* Part number is for one piece.

Wiring

Spring Type Terminal Block Box

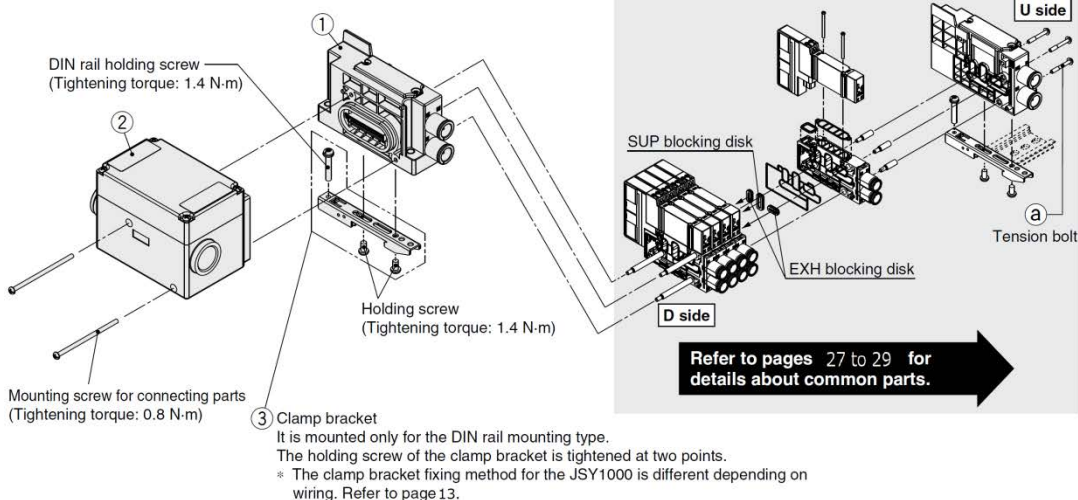

Manifold Parts Nos.

① SUP/EXH block assembly

JSY **3** 1M-1P-1A **C10**

Series

1	JSY1000
3	JSY3000
5	JSY5000

Mounting

Nil	Direct mounting
D0	DIN rail mounting (Without DIN rail)

Pilot, Silencer type

Symbol	Pilot type		Built-in silencer
	Internal	External (Made to Order)	
Nil	●	—	—
S	●	—	●
R	—	●	—

* 3/5(E) port is plugged for the built-in silencer type.

P, E port size (One-touch fittings)

Symbol	P, E port	JSY1000	JSY3000	JSY5000
C8	ø8 One-touch fitting	●	—	—
C10	ø10 One-touch fitting	—	●	—
C12	ø12 One-touch fitting	—	—	●
00*1	Plug	●	●	●

*1 Can be selected when the pilot, silencer type symbol is "Nil" or "S."
Not available for "R" type.

SUP/EXH block assembly (D side) accessories and the number of accessories

Accessories	JSY1000	JSY5000
① Tension bolt	None*1	3 pcs.

*1 Since the nuts are embedded in the SUP/EXH block.

② Terminal block assembly

SY30M-130-1A

③ Clamp bracket

Series	Part no.
JSY1000	JSY11M-15P-1A
JSY3000	SY30M-15-1A
JSY5000	SY50M-15-1A

* Part number is for one piece.

Wiring

Terminal Block Box

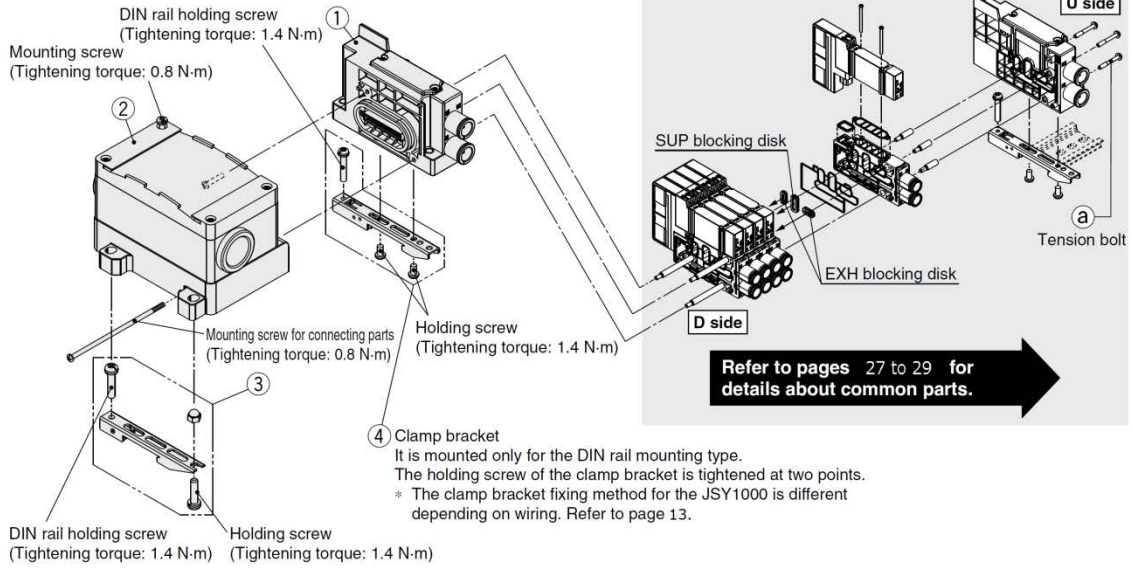

Manifold Parts Nos.

① SUP/EXH block assembly

JSY 3 1M-1P-1A - C10

Series

1	JSY1000
3	JSY3000
5	JSY5000

Mounting

Symbol	Mounting	JSY1000	JSY3000	JSY5000
Nil	Direct mounting	●	●	●
D00	DIN rail mounting (Without DIN rail)	●	—	—
D0	DIN rail mounting (Without DIN rail)	—	●	●

Pilot, Silencer type

Symbol	Pilot type		Built-in silencer
	Internal	External (Made to Order)	
Nil	●	—	—
S	●	—	●
R	—	●	—

* 3/5(E) port is plugged for the built-in silencer type.

P, E port size (One-touch fittings)

Symbol	P, E port	JSY1000	JSY3000	JSY5000
C8	ø8 One-touch fitting	●	—	—
C10	ø10 One-touch fitting	—	●	—
C12	ø12 One-touch fitting	—	—	●
00 ^{*1}	Plug	●	●	●

*1 Can be selected when the pilot, silencer type symbol is "Nil" or "S."
 Not available for "R" type.

SUP/EXH block assembly (D side) accessories and the number of accessories

Accessories	JSY1000 JSY3000	JSY5000
Ⓐ Tension bolt	None ^{*1}	3 pcs.

*1 Since the nuts are embedded in the SUP/EXH block.

② Terminal block box housing assembly

VVQC1000-T0-1

③ Clamp bracket for terminal block box

SY30M-15-4A

④ Clamp bracket

Series	Part no.
JSY1000	JSY11M-15P-2A
JSY3000	SY30M-15-1A
JSY5000	SY50M-15-1A

* Part number is for one piece.

Wiring

Lead Wire

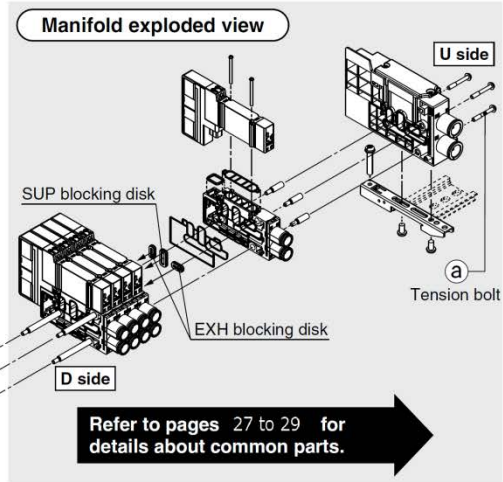
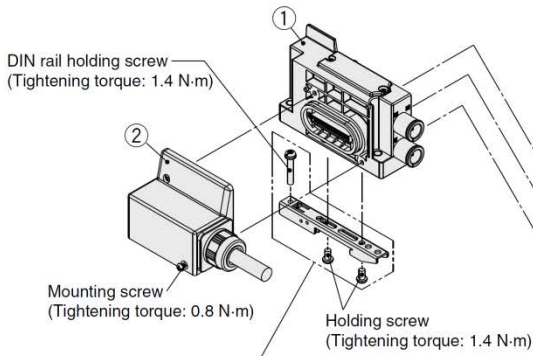

③ Clamp bracket
It is mounted only for the DIN rail mounting type.
The holding screw of the clamp bracket is tightened at two points.
* The clamp bracket fixing method for the JSY1000 is different depending on wiring. Refer to page 13.

Manifold Parts Nos.

① SUP/EXH block assembly

JSY **3** 1M-1P-1A **C10**

Series

1	JSY1000
3	JSY3000
5	JSY5000

Mounting

Nil	Direct mounting
D0	DIN rail mounting (Without DIN rail)

Pilot, Silencer type

Symbol	Pilot type		Built-in silencer
	Internal	External (Made to Order)	
Nil	●	—	—
S	●	—	●
R	—	●	—

* 3/5(E) port is plugged for the built-in silencer type.

P, E port size (One-touch fittings)

Symbol	P, E port	JSY1000	JSY3000	JSY5000
C8	ø8 One-touch fitting	●	—	—
C10	ø10 One-touch fitting	—	●	—
C12	ø12 One-touch fitting	—	—	●
00*1	Plug	●	●	●

*1 Can be selected when the pilot, silencer type symbol is "Nil" or "S."
Not available for "R" type.

SUP/EXH block assembly (D side) accessories and the number of accessories

Accessories	JSY1000 JSY3000	JSY5000
Ⓐ Tension bolt	None*1	3 pcs.

*1 Since the nuts are embedded in the SUP/EXH block.

② Lead wire connector block assembly

SY30M-14-4A-**1**-**1**

Number of cores (Lead wire)

Symbol	Number of cores
1	34
2	17
3	9

Lead wire length [m]

Symbol	Length
1	0.6
2	1.5
3	3

③ Clamp bracket

Series	Part no.
JSY1000	JSY11M-15P-1A
JSY3000	SY30M-15-1A
JSY5000	SY50M-15-1A

* Part number is for one piece.

Wiring

EX600

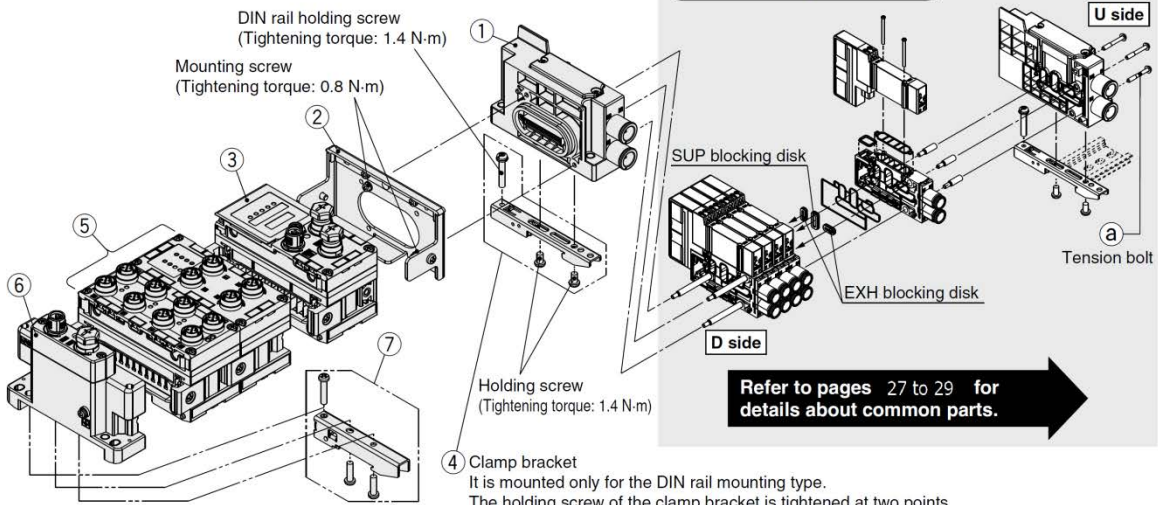

Manifold Parts Nos.

① SUP/EXH block assembly

JSY 3 1M-1P-1A - C10

Series

1	JSY1000
3	JSY3000
5	JSY5000

Mounting

Symbol	Mounting	JSY1000	JSY3000	JSY5000
Nil	Direct mounting	●	●	●
D00	DIN rail mounting (Without DIN rail)	●	—	—
DO	DIN rail mounting (Without DIN rail)	—	●	●

Pilot, Silencer type

Symbol	Pilot type		Built-in silencer
	Internal	External (Made to Order)	
Nil	●	—	—
S	●	—	●
R	—	●	—

* 3/5(E) port is plugged for the built-in silencer type.

P, E port size (One-touch fittings)

Symbol	P, E port	JSY1000	JSY3000	JSY5000
C8	ø8 One-touch fitting	●	—	—
C10	ø10 One-touch fitting	—	●	—
C12	ø12 One-touch fitting	—	—	●
00*1	Plug	●	●	●

*1 Can be selected when the pilot, silencer type symbol is "Nil" or "S." Not available for "R" type.

SUP/EXH block assembly (D side) accessories and the number of accessories

Accessories	JSY1000/3000	JSY5000
① Tension bolt	None*1	3 pcs.

*1 Since the nuts are embedded in the SUP/EXH block

② Valve plate

EX600-ZMV2

* With mounting screws (2 pcs. of M4 x 6 and 2 pcs. of M3 x 8)

④ Clamp bracket

Series	Part no.
JSY1000	JSY11M-15P-2A
JSY3000	SY30M-15-1A
JSY5000	SY50M-15-1A

* Part number is for one piece.

③ EX600 SI unit

EX600-S PR 1

Protocol

Symbol	Description
PR	PROFIBUS DP
DN	DeviceNet™
MJ	CC-Link
EN	EtherNet/IP™*1
EC	EtherCAT*1
PN	PROFINET*1

*1 Cannot be communicated with the EX600-HT1-□

Version

Symbol	Description
Nil	When MJ, EN, EC, or PN is selected
A	When PR or DN is selected

Output type

Symbol	Description	Condition
1	PNP (Negative common)	Can be selected by all protocols excluding EN
2	NPN (Positive common)	Can be selected by all protocols excluding EN
3	PNP (Negative common) EtherNet/IP™ (2 ports)	Can be selected in the case of EN
4	NPN (Positive common) EtherNet/IP™ (2 ports)	Can be selected in the case of EN

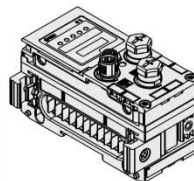

(Wireless compatible)

EX600-W EN 1

Protocol

Symbol	SI unit type	Description
EN	Wireless base module	EtherNet/IP™*1
PN	Wireless base module	PROFINET™*1
SV	Wireless remote module	—*1

*1 Cannot be communicated with the EX600-HT1-□
* The wireless system is suitable for use only in a country where it is in accordance with the Radio Act and regulations of that country.

Output type

Symbol	Description
1	PNP (Negative common)
2	NPN (Positive common)

Manifold Parts Nos.

⑤ EX600 Digital input unit

EX600-DX **P** **B**

Symbol	Description
P	PNP
N	NPN

Input type

Number of inputs, Open-circuit detection, and Connector

Symbol	Number of inputs	Open-circuit detection	Connector
B	8	No	M12 connector (5 pins) 4 pcs.
C	8	No	M8 connector (3 pins) 8 pcs.
C1	8	Yes	M8 connector (3 pins) 8 pcs.
D	16	No	M12 connector (5 pins) 8 pcs.
E	16	No	D-sub connector (25 pins) ^{*1*2}
F	16	No	Spring type terminal block (32 pins) ^{*1*2}

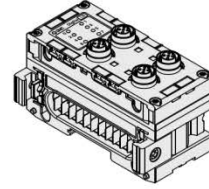

⑤ EX600 Digital output unit

EX600-DY **P** **B**

Symbol	Description
P	PNP
N	NPN

Output type

Number of outputs and Connector

Symbol	Number of outputs	Connector
B	8	M12 connector (5 pins) 4 pcs.
E	16	D-sub connector (25 pins) ^{*1*2}
F	16	Spring type terminal block (32 pins) ^{*1*2}

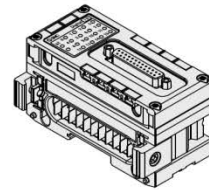

⑤ EX600 Digital input/output unit

EX600-DM **P** **E**

Input/Output type

Symbol	Description
P	PNP
N	NPN

Number of inputs/outputs and Connector

Symbol	Number of inputs	Number of outputs	Connector
E	8	8	D-sub connector (25 pins) ^{*1*2}
F	8	8	Spring type terminal block (32 pins) ^{*1*2}

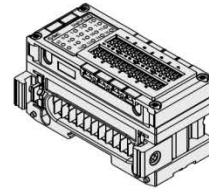

⑤ EX600 Analog input/output unit

EX600-AX **A**

Analog input/output

Symbol	Description
AX	Analog input
AY	Analog output

Number of input channels and Connector

Symbol	Number of input channels	Connector
A	2 channels	M12 connector (5 pins) 2 pcs. ^{*3}

*3 Refer to *1 and *2 below for AY.

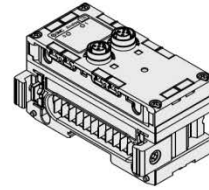

⑤ EX600 Analog input/output unit

EX600-AM **B**

Analog input/output

Number of input/output channels and Connector

Symbol	Number of input channels	Number of output channels	Connector
B	2 channels	2 channels	M12 connector (5 pins) 4 pcs. ^{*1*2}

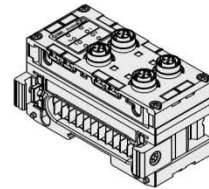

⑥ EX600 End plate

EX600-ED **2** - **□**

Power connector

Symbol	Connector
2	M12 power supply connector, B-coded
3	7/8 inch power supply connector
4	M12 power supply connector IN/OUT, A-coded, Pin arrangement 1
5	M12 power supply connector IN/OUT, A-coded, Pin arrangement 2

Mounting

Symbol	Description
Nil	Without DIN rail mounting bracket
3	With DIN rail mounting bracket

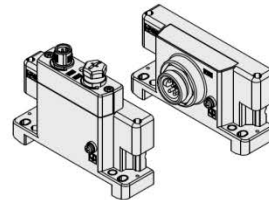

* The pin layout for "4" and "5" pin connector is different.

⑦ Clamp bracket for EX600

EX600-ZMA3

Enclosed parts

Round head screw with washer (M4 x 20) 1 pc.
P-tight screw (4 x 14) 2 pcs.



*1 Cannot be communicated with the EX600-HT1-□ (Old version of the handheld terminal)

*2 Cannot be connected with the EX600-SPR1, EX600-SPR2, EX600-SDN1, or EX600-SDN2

Wiring

EX250

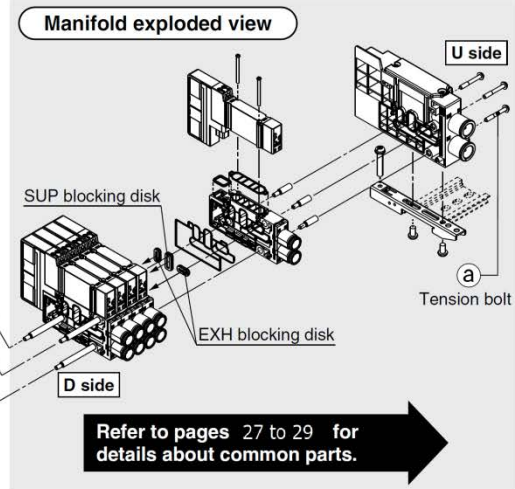
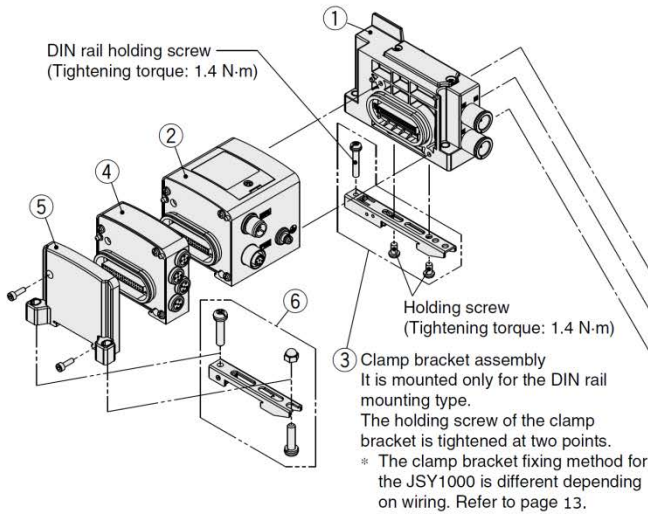

Manifold Parts Nos.

① SUP/EXH block assembly

JSY **3** 1M-1P-1A **C10**

Series

1	JSY1000
3	JSY3000
5	JSY5000

Mounting

Symbol	Mounting	JSY1000	JSY3000	JSY5000
Nil	Direct mounting	●	●	●
D00	DIN rail mounting (Without DIN rail)	●	—	—
D0	DIN rail mounting (With DIN rail)	—	●	●

Pilot, Silencer type

Symbol	Pilot type		Built-in silencer
	Internal	External (Made to Order)	
Nil	●	—	—
S	—	—	●
R	—	●	—

* 3/5(E) port is plugged for the built-in silencer type.

P, E port size (One-touch fittings)

Symbol	P, E port	JSY1000	JSY3000	JSY5000
C8	ø8 One-touch fitting	●	—	—
C10	ø10 One-touch fitting	—	●	—
C12	ø12 One-touch fitting	—	—	●
00 ^{*1}	Plug	●	●	●

*1 Can be selected when the pilot, silencer type symbol is "Nil" or "S." Not available for "R" type.

SUP/EXH block assembly (D side) accessories and the number of accessories

Accessories	JSY1000	JSY3000	JSY5000
Ⓐ Tension bolt	None ^{*1}	—	3 pcs.

*1 Since the nuts are embedded in the SUP/EXH block

② EX250 SI unit

EX250-S **DN1**

Communication protocol

DN1	DeviceNet™ (Negative common)
PR1	PROFIBUS DP (Negative common)
AS3	AS-Interface (8 in/8 out, 31 slave modes, 2 isolated common type) (Negative common)
AS5	AS-Interface (4 in/4 out, 31 slave modes, 2 isolated common type) (Negative common)
AS7	AS-Interface (8 in/8 out, 31 slave modes, 1 common type) (Negative common)
AS9	AS-Interface (4 in/4 out, 31 slave modes, 1 common type) (Negative common)
CA1A	CANopen (Negative common)
EN1	EtherNet/IP™ (Negative common)

③ Clamp bracket

Series	Part no.
JSY1000	JSY11M-15P-2A
JSY3000	SY30M-15-1A
JSY5000	SY50M-15-1A

* Part number is for one piece.

④ Input block

EX250-IE **1**

Block type

1	M12 connector, 2 inputs
2	M12 connector, 4 inputs
3	M8 connector, 4 inputs

⑤ EX250 End plate assembly

EX250-EA1

* With mounting screws (2 pcs. of M3 x 10)

⑥ Clamp bracket assembly for EX250

SY30M-15-3A

* Part number is for one assembly.

Wiring

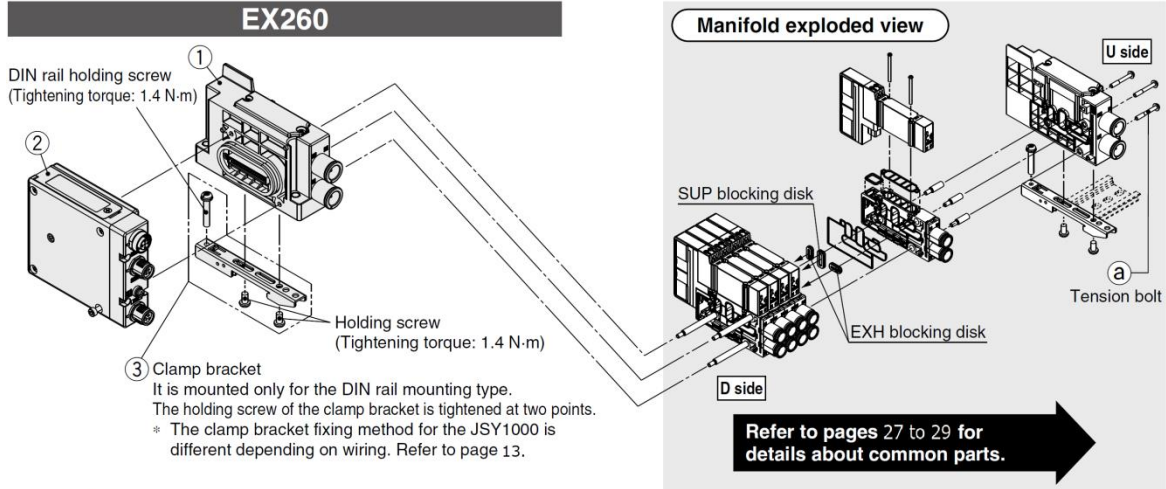

Manifold Parts Nos.

① SUP/EXH block assembly

JSY **3** 1M-1P-1A **C10**

Series

1	JSY1000
3	JSY3000
5	JSY5000

Mounting

Nil	Direct mounting
D0	DIN rail mounting (Without DIN rail)

Pilot, Silencer type

Symbol	Pilot type		Built-in silencer
	Internal	External (Made to Order)	
Nil	●	—	—
S	●	—	●
R	—	●	—

* 3/5(E) port is plugged for the built-in silencer type.

P, E port size (One-touch fittings)

Symbol	P, E port	JSY1000	JSY3000	JSY5000
C8	ø8 One-touch fitting	●	—	—
C10	ø10 One-touch fitting	—	●	—
C12	ø12 One-touch fitting	—	—	●
00*1	Plug	●	●	●

*1 Can be selected when the pilot, silencer type symbol is "Nil" or "S." Not available for "R" type.

SUP/EXH block assembly (D side) accessories and the number of accessories

Accessories	JSY1000/3000	JSY5000
a) Tension bolt	None*1	3 pcs.

*1 Since the nuts are embedded in the SUP/EXH block

② EX260 SI unit

EX260-S **PR1**

Communication protocol

Symbol	Protocol	Number of outputs	SI unit output polarity	Communication connector	Manifold symbol	Symbol	Protocol	Number of outputs	SI unit output polarity	Communication connector	Manifold symbol
DN1	DeviceNet™	32	Source/PNP (Negative common)	M12	QAN	EC1	EtherCAT	32	Source/PNP (Negative common)	M12	DAN
DN2			Sink/NPN (Positive common)		QA	EC2			Sink/NPN (Positive common)		DA
DN3		Source/PNP (Negative common)	QBN		EC3	Source/PNP (Negative common)		DBN			
DN4		Sink/NPN (Positive common)	QB		EC4	Sink/NPN (Positive common)		DB			
PR1	PROFIBUS DP	32	Source/PNP (Negative common)	M12	NAN	PN1	PROFINET	32	Source/PNP (Negative common)	M12	FAN
PR2			Sink/NPN (Positive common)		NA	PN2			Sink/NPN (Positive common)		FA
PR3		Source/PNP (Negative common)	NBN		PN3	Source/PNP (Negative common)		FBN			
PR4		Sink/NPN (Positive common)	NB		PN4	Sink/NPN (Positive common)		FB			
PR5		Source/PNP (Negative common)	NCN		EN1	Source/PNP (Negative common)		EAN			
PR6		Sink/NPN (Positive common)	NC		EN2	Sink/NPN (Positive common)		EA			
PR7		Source/PNP (Negative common)	NDN		EN3	Source/PNP (Negative common)		EBN			
PR8		Sink/NPN (Positive common)	ND		EN4	Sink/NPN (Positive common)		EB			
MJ1	CC-Link	32	Source/PNP (Negative common)	M12	VAN	PL1	Ethernet	32	Source/PNP (Negative common)	M12	GAN
MJ2			Sink/NPN (Positive common)		VA	PL3			POWERLINK		16
MJ3		Source/PNP (Negative common)	VBN		IL1	IO-Link	32	Source/PNP (Negative common)	M12		KAN
MJ4		Sink/NPN (Positive common)	VB								

*1 Enclosure is IP40 when the communication connector is D-sub.

③ Clamp bracket

Series	Part no.
JSY1000	JSY11M-15P-1A
JSY3000	SY30M-15-1A
JSY5000	SY50M-15-1A

* Part number is for one piece.

Wiring

EX120

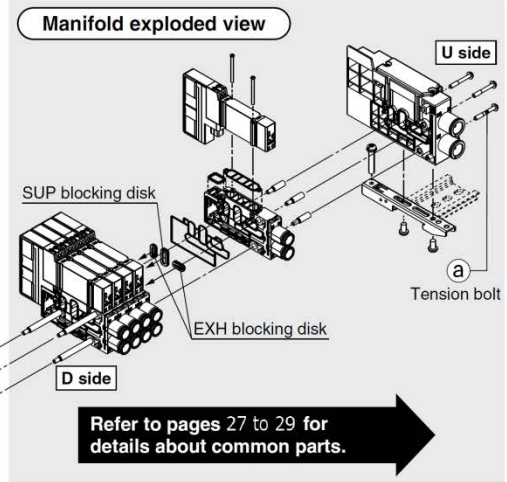
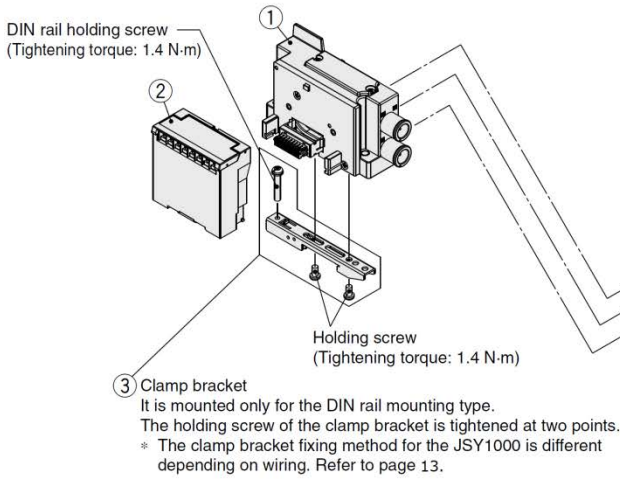

Manifold Parts Nos.

① SUP/EXH block assembly

JSY **3** 1M-1P-14A - C10

Series

1	JSY1000
3	JSY3000
5	JSY5000

Mounting

Nil	Direct mounting
D0	DIN rail mounting (Without DIN rail)

Pilot, Silencer type

Symbol	Pilot type		Built-in silencer
	Internal	External (Made to Order)	
Nil	●	—	—
S	●	—	●
R	—	●	—

* 3/5(E) port is plugged for the built-in silencer type.

P, E port size (One-touch fittings)

Symbol	P, E port	JSY1000	JSY3000	JSY5000
C8	ø8 One-touch fitting	●	—	—
C10	ø10 One-touch fitting	—	—	—
C12	ø12 One-touch fitting	—	—	●
00 ^{*1}	Plug	●	●	●

*1 Can be selected when the pilot, silencer type symbol is "Nil" or "S." Not available for "R" type.

SUP/EXH block assembly (D side) accessories and the number of accessories

Accessories	JSY1000/3000	JSY5000
② Tension bolt	None ^{*1}	3 pcs.

*1 Since the nuts are embedded in the SUP/EXH block

② EX120 SI unit

EX120-S **DN1**

Communication protocol

DN1	DeviceNet™ (Positive common)
CS1	OMRON Corp.: CompoBus/S (16 outputs) (Positive common)
CS2	OMRON Corp.: CompoBus/S (8 outputs) (Positive common)
MJ1	CC-Link (Positive common)
CM1	CompoNet™ NPN (Positive common)
CM3	CompoNet™ PNP (Negative common)

③ Clamp bracket

Series	Part no.
JSY1000	JSY11M-15P-1A
JSY3000	SY30M-15-1A
JSY5000	SY50M-15-1A

* Part number is for one piece.

Manifold Exploded View [Common Parts]

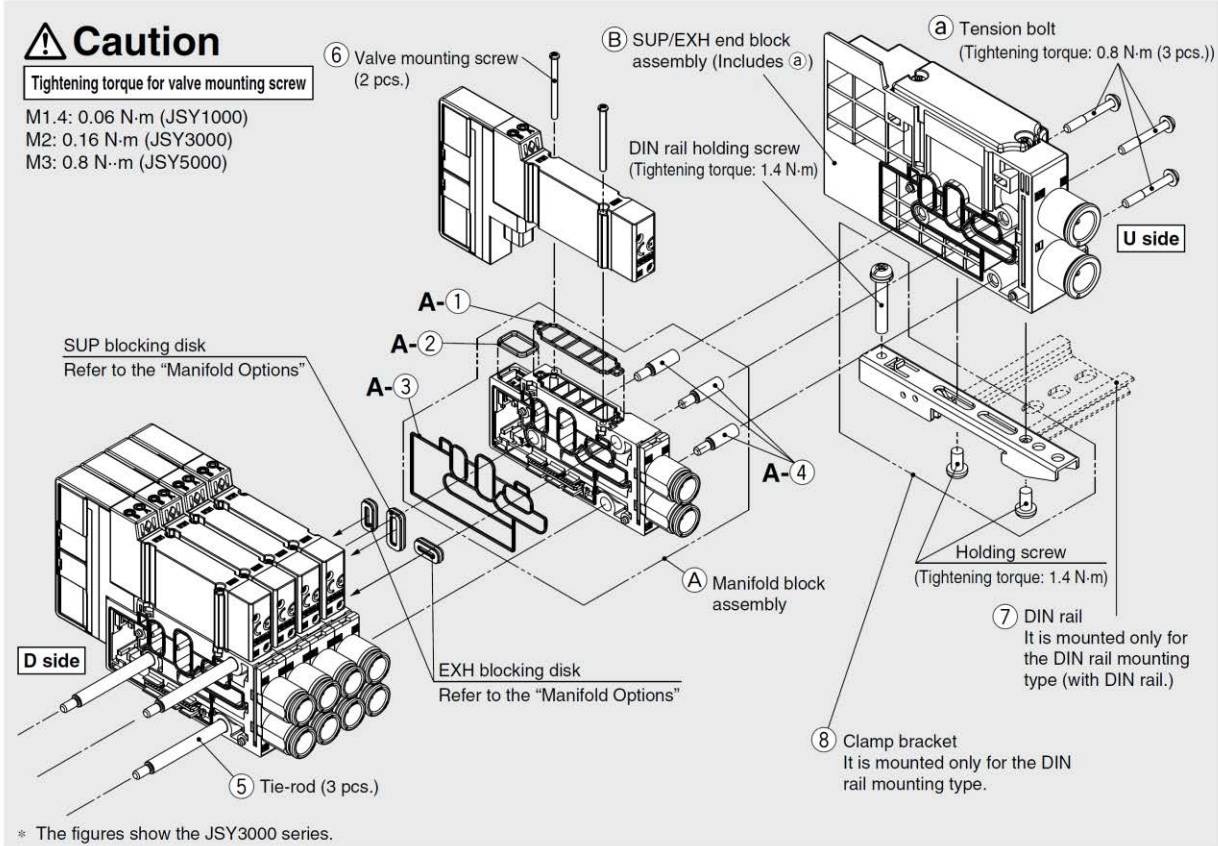

Type 10: How to Increase Connector Type Manifolds

- 1 Loosen the U-side tension bolt (a), and remove the B SUP/EXH end block assembly.
- 2 Screw in (4) tie-rods for additional stations to the (5) tie-rod of the manifold.
(Screw them in until there is no gap between the tie-rods.)
- 3 Connect the A manifold block assembly and B SUP/EXH end block assembly to be added, and tighten the tension bolt (a).

Tightening torque for tension bolt (a) (M3): 0.8 N·m

Caution

1. Be sure to shut off the power and air supplies before disassembly. Furthermore, since air may remain inside the actuator, piping and manifold, confirm that the air is completely exhausted before performing any work.
2. When disassembly and assembly are performed, air leakage may result if the tightening of the tension bolt is inadequate.

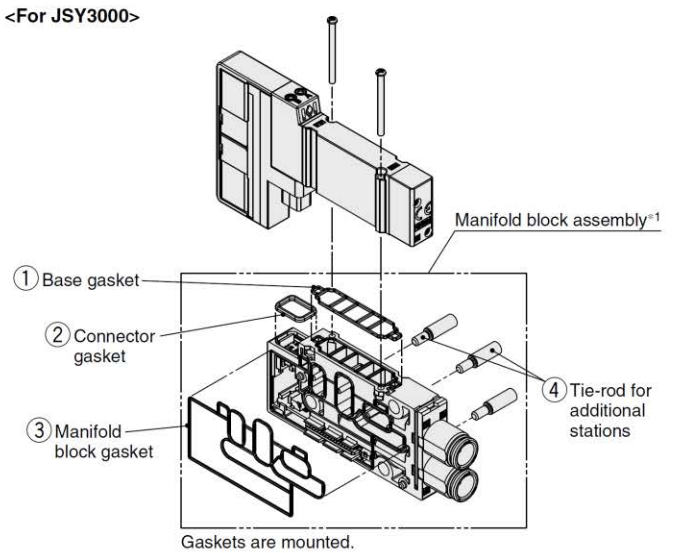

*1 Manifold block assembly

No.	Description	Quantity	Note
①②③	Gasket	1 pc. of each	For base, connector and manifold block
④	Tie-rod for additional stations	3	

* ② Connector gasket is not applicable to the JSY1000.

For JJ5SY1-10, JJ5SY3-10, JJ5SY5-10

No.	Description	JSY1000		JSY3000	JSY5000	Note
		6.5 mm pitch	9 mm pitch			
A-①	Manifold block assembly	JSY11M-9P-1A		JSY31M-9P-1A	JSY51M-9P-1A	Part numbers shown on the left are for 10 valves. (10 pcs.) Supplied individually
A-②		—		SX3000-146-2		
A-③	Manifold block gasket	JSY11M-9P-2		JSY31M-9P-2	JSY51M-9P-2	Supplied individually
A-④	Tie-rod for additional stations*1	JSY11M-49P-1-1-A (6.5 mm pitch)	JSY11M-49P-2-1-A (9 mm pitch)	JSY31M-49P-1-1-A (11.5 mm pitch)	SV2000-55-2A-A (16 mm pitch)	3 pcs. supplied
⑤	Tie-rod	JSY11M-49P-1-□-A (6.5 mm pitch)	JSY11M-49P-2-□-A (9 mm pitch)	JSY31M-49P-1-□-A (11.5 mm pitch)	SV2000-55-1-□-A (16 mm pitch)	□: Manifold stations (2 to 24 stations) 3 pcs. supplied
⑥	Valve mounting screw	JSY11V-23-1A (M1.4 x 21.5)		JSY31V-23-1A (M2 x 25)	JSY51V-23-1A (M3 x 29)	Part numbers shown on the left are for 10 valves. (20 pcs.)
⑦	DIN rail	VZ1000-11-1-□			VZ1000-11-4-□	
⑧	Clamp bracket*2 (for connector connecting base)	JSY11M-15P-1A (Refer to the table below.) JSY11M-15P-2A (Refer to the table below.)		SY30M-15-1A	SY50M-15-1A	Supplied individually

*1 The manifold of the JSY1000/3000 (JJ5SY1-10/JJ5SY3-10) can be assembled by connecting the tie-rods for number of manifold stations. The manifold of the JSY5000 (JJ5SY5-10) cannot be assembled by connecting the tie-rods for additional stations for the number of manifold. Tie-rod (SV2000-55-1-□-A) is necessary.

*2 Part number of the clamp bracket for the JSY1000 is different depending on the manifold wiring. Refer to the table below.

Table. JSY1000 series clamp bracket

Wiring (JSY1000 series)	JSY11M-15P-1A	JSY11M-15P-2A
F D-sub connector	●	—
P□ Flat ribbon cable	●	—
TC Spring type terminal block box	●	—
T Terminal block box	—	●
L Lead wire	●	—
S6 EX600	—	●
S□ EX250	—	●
S□□ EX260	●	—
S3 EX120	●	—

Manifold Parts Nos.

Ⓐ Manifold block assembly

JSY **3** 1M-2P-1 D A-C8

Series

1	JSY1000
3	JSY3000
5	JSY5000

Manifold pitch

1	JSY1000 (6.5 mm pitch) JSY3000 (11.5 mm pitch) JSY5000 (16 mm pitch)
2	JSY1000 (9 mm pitch)

Wiring type

S	Single wiring
D	Double wiring

A, B port size (One-touch fittings)

Symbol	A, B port	JSY1000		JSY3000	JSY5000
		6.5 mm pitch	9 mm pitch		
C2	ø2 One-touch fitting	●	—	—	—
C4	ø4 One-touch fitting	●	—	—	—
C6	ø6 One-touch fitting	—	●	●	—
C8	ø8 One-touch fitting	—	—	●	—
C10	ø10 One-touch fitting	—	—	—	●
C12	ø12 One-touch fitting	—	—	—	●

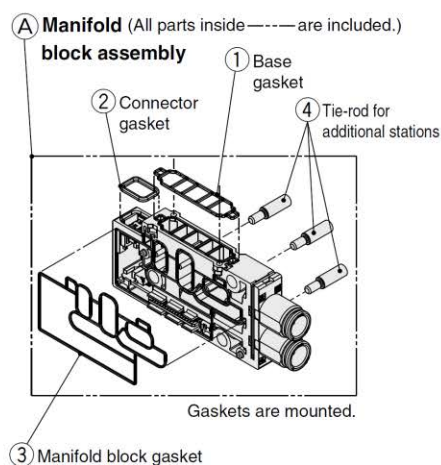

Manifold block assembly accessories and the number of accessories

Accessories	Quantity
① Base gasket	1 pc.
② Connector gasket*1	1 pc.
③ Manifold block gasket	1 pc.
④ Tie-rod for additional stations	3 pcs.

*1 Not applicable to the JSY1000 series.

Manifold Parts Nos.

⑧ SUP/EXH end block assembly

JSY 3 1M-3P-1A - **C10**

Series

1	JSY1000
3	JSY3000
5	JSY5000

Pilot, Silencer type

Symbol	Pilot type		Built-in silencer
	Internal	External (Made to Order)	
Nil	●	—	—
S	●	—	●
R	—	●	—

* 3/5(E) port is plugged for the built-in silencer type.

P, E port size (One-touch fittings)

Symbol	P, E port	JSY1000	JSY3000	JSY5000
C8	ø8 One-touch fitting	●	—	—
C10	ø10 One-touch fitting	—	●	—
C12	ø12 One-touch fitting	—	—	●
00*1	Plug	●	●	●

*1 Can be selected when the pilot, silencer type symbol is "Nil" or "S." Not available for "R" type.

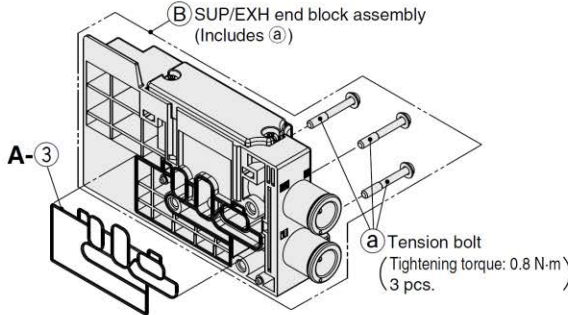

Mounting

Nil	Direct mounting
D0	DIN rail mounting (Without DIN rail)
D00*1	DIN rail mounting (Without DIN rail)

*1 Part number only for the JSY1000

Part number is different depending on the wiring. Refer to Table 1.

Table 1. JSY1000 series DIN rail mounting

Symbol	Wiring
D0	D-sub connector (F type)
	Flat ribbon cable (P□ type)
	Spring type terminal block box (TC type)
	Lead wire (L type)
D00	EX260 (S□□ type)
	EX120 (S3 type)
	Terminal block box (T type)
D00	EX600 (S6 type)
	EX250 (S□ type)

SUP/EXH end block assembly accessories and the number of accessories

Accessories	Quantity
① Tension bolt	3 pcs.
A-③ Manifold block gasket	1 pc.

* Gasket is mounted.

⑧ Clamp bracket

Series	Part no.	
JSY1000	For D0	JSY11M-15P-1A
	For D00	JSY11M-15P-2A
JSY3000		SY30M-15-1A
JSY5000		SY50M-15-1A

* Part number is for one piece.

* Part number of the JSY1000 is different depending on the manifold wiring. Refer to the Table 1. JSY1000 series DIN rail mounting for selecting a clamp bracket.

■ Cover, Silencer cover, Port block for SUP/EXH (end) block assembly

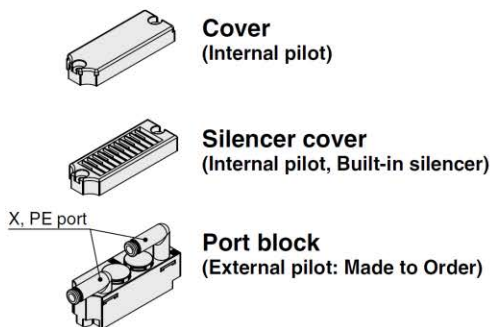

* Cover, silencer cover, and port block are included in the SUP/EXH (end) block assembly, but they need to be ordered for piping specification change.
* Mounting screws (2 pcs.) for SUP/EXH end block assembly are included.

Tightening torque for mounting screw
JSY1000 (M2.5): 0.32 N·m
JSY3000 (M3): 0.8 N·m
JSY5000 (M4): 1.4 N·m

JSY 3 1M-4P-1A

JSY 3 1M-5P-1A

JSY 3 1M-6P-1AR-00

Series

1	JSY1000
3	JSY3000
5	JSY5000

⚠ Caution

1. Be sure to shut off the power and air supplies before disassembly. Furthermore, since air may remain inside the actuator, piping and manifold, confirm that the air is completely exhausted before performing any work.
2. When disassembly and assembly are performed, air leakage may result if the tightening of the cover and port block assemblies are inadequate.

One-touch Fittings, Plug, Clip, Port Plate, Tube Releasing Tool

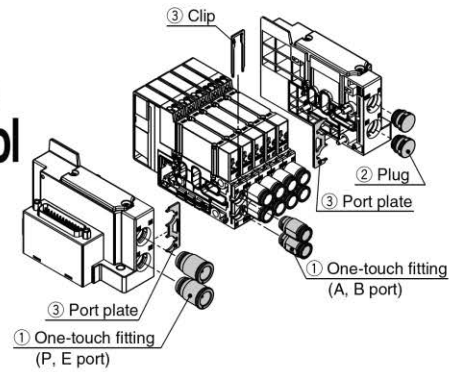

① One-touch Fittings

Port size	Series	JSY1000		JSY3000	JSY5000	Note
		6.5 mm pitch	9 mm pitch			
A, B port	ø2	KQSY10-C2	—	—	—	Part number is for one piece. Please order by 10 pieces.
	ø4	KQSY10-C4-X1336	—	—	—	
	ø6	—	KQSY11-C6-X1336	KQSY30-C6	—	
	ø8	—	—	KQSY30-C8-X1336	—	
	ø10	—	—	—	KQSY50-C10	
ø12	—	—	—	KQSY50-C12-X1336		
P, E port	ø8	KQSY30-C8-X1336		—	—	
	ø10	—	—	KQSY31-C10-X1336	—	
	ø12	—	—	—	KQSY50-C12-X1336	

② Plug

Piping port	Series	JSY1000	JSY3000	JSY5000	Note
P, E port		JSY11M-62P-1A	JSY31M-62P-1A	JSY51M-62P-1A	Part number is for one piece.

* A, B port plug does not exist. Use the KQ2P series.

③ Clip, Port Plate

Piping port	Series	JSY1000		JSY3000	JSY5000	Note
		For A, B port C2/C4 fittings	For A, B port C6 fittings			
A, B port (Clip)		SJ1000-CL-1	JSY11M-19P-1A	JSY31M-19P-1A	JSY51M-19P-1A	Part number is for 10 pieces.
P, E port (Port plate)		JSY11M-10P-1		JSY31M-10P-1	JSY51M-10P-1	Part number is for one piece.

■ Tube Releasing Tool (This tool is used for removing the tube from port A and B.)

Series	For JSY1000		For JSY3000	For JSY5000
	6.5 mm pitch	9 mm pitch		
Part no.	TG-0204	TG-0608	TG-0608	TG-1012
Applicable tubing O.D.	ø2/ø4	ø6	ø6/ø8	ø10/ø12



Tube removal procedure

- (1) Set the release tool to the outside diameter surface.
- (2) Push the fitting release bushing using the release tool.
- (3) Remove the tube.

Manifold Options

■ DIN rail dimensions/weight for the JSY1000/3000 **Plug-in** connector connecting base

VZ1000-11-1-□

* After confirming the L3 dimension in the dimensions table of each series, refer to the DIN rail dimensions table below and specify the number in the box □.

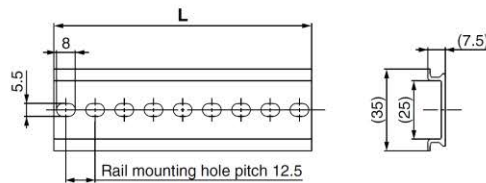

No.	0	1	2	3	4	5	6	7	8	9	10	11	12	13	14	15	16	17	18
L dimension	98	110.5	123	135.5	148	160.5	173	185.5	198	210.5	223	235.5	248	260.5	273	285.5	298	310.5	323
Weight [g]	17.6	19.9	22.1	24.4	26.6	28.9	31.1	33.4	35.6	37.9	40.1	42.4	44.6	46.9	49.1	51.4	53.6	55.9	58.1
No.	19	20	21	22	23	24	25	26	27	28	29	30	31	32	33	34	35	36	37
L dimension	335.5	348	360.5	373	385.5	398	410.5	423	435.5	448	460.5	473	485.5	498	510.5	523	535.5	548	560.5
Weight [g]	60.4	62.5	64.9	67.1	69.4	71.6	73.9	76.1	78.4	80.6	82.9	85.1	87.4	89.6	91.9	94.1	96.4	98.6	100.9
No.	38	39	40	41	42	43	44	45	46	47	48	49	50	51	52	53	54	55	56
L dimension	573	585.5	598	610.5	623	635.5	648	660.5	673	685.5	698	710.5	723	735.5	748	760.5	773	785.5	798
Weight [g]	103.1	105.4	107.6	109.9	112.1	114.4	116.6	118.9	121.1	123.4	125.6	127.9	130.1	132.4	134.6	136.9	139.1	141.4	143.6
No.	57	58	59	60	61	62	63	64	65	66	67	68	69	70	71				
L dimension	810.5	823	835.5	848	860.5	873	885.5	898	910.5	923	935.5	948	960.5	973	985.5				
Weight [g]	145.9	148.1	150.4	152.6	154.9	157.1	159.4	161.6	163.9	166.1	168.4	170.6	172.9	175.1	177.4				

■ DIN rail dimensions/weight for the JSY5000 **Plug-in** connector connecting base

VZ1000-11-4-□

* After confirming the L3 dimension in the dimensions table of each series, refer to the DIN rail dimensions table below and specify the number in the box □.

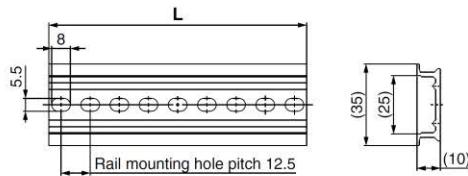

No.	0	1	2	3	4	5	6	7	8	9	10	11	12	13	14	15	16	17	18
L dimension	98	110.5	123	135.5	148	160.5	173	185.5	198	210.5	223	235.5	248	260.5	273	285.5	298	310.5	323
Weight [g]	24.8	28	31.1	34.3	37.4	40.6	43.8	46.9	50.1	53.3	56.4	59.6	62.7	65.9	69.1	72.2	75.4	78.6	81.7
No.	19	20	21	22	23	24	25	26	27	28	29	30	31	32	33	34	35	36	37
L dimension	335.5	348	360.5	373	385.5	398	410.5	423	435.5	448	460.5	473	485.5	498	510.5	523	535.5	548	560.5
Weight [g]	84.9	88	91.2	94.4	97.5	100.7	103.9	107	110.2	113.3	116.5	119.7	122.8	126	129.2	132.3	135.5	138.6	141.8
No.	38	39	40	41	42	43	44	45	46	47	48	49	50	51	52	53	54	55	56
L dimension	573	585.5	598	610.5	623	635.5	648	660.5	673	685.5	698	710.5	723	735.5	748	760.5	773	785.5	798
Weight [g]	145	148.1	151.3	154.5	157.6	160.8	163.9	167.1	170.3	173.4	176.6	179.8	182.9	186.1	189.2	192.4	195.6	198.7	201.9
No.	57	58	59	60	61	62	63	64	65	66	67	68	69	70	71				
L dimension	810.5	823	835.5	848	860.5	873	885.5	898	910.5	923	935.5	948	960.5	973	985.5				
Weight [g]	205.1	208.2	211.4	214.5	217.7	220.9	224	227.2	230.4	233.5	236.7	239.8	243	246.2	249.3				

⚠ Caution	Tightening torque for mounting screw
	M1.4: 0.06 N-m (JSY1000)
	M2: 0.16 N-m (JSY3000) M3: 0.8 N-m (JSY5000)

■ Blanking plate

[With two mounting screws]

Used when valve additions are expected or for maintenance.

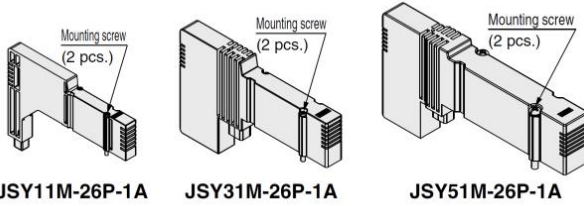

JSY 3 1M - 26P - 1A

● Series

1	JSY1000
3	JSY3000
5	JSY5000

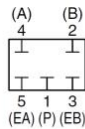

Circuit diagram

■ Individual SUP spacer

[With a connector gasket, a base gasket, and two mounting screws]

When the same manifold is used for different pressures, an individual SUP spacer assembly is used as a supply port for different pressures.

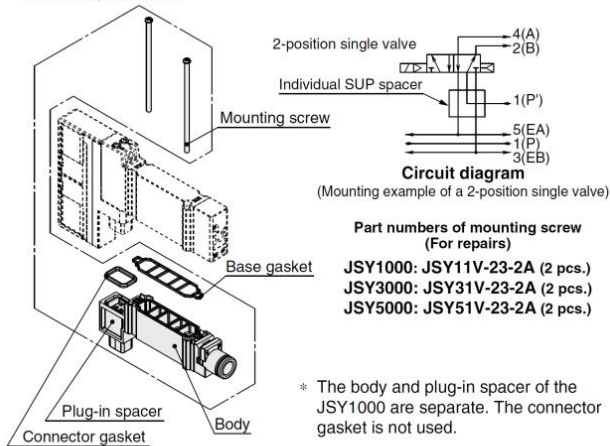

Circuit diagram
(Mounting example of a 2-position single valve)

Part numbers of mounting screw
(For repairs)
JSY1000: JSY11V-23-2A (2 pcs.)
JSY3000: JSY31V-23-2A (2 pcs.)
JSY5000: JSY51V-23-2A (2 pcs.)

* The body and plug-in spacer of the JSY1000 are separate. The connector gasket is not used.

JSY 3 1M - 38 P - 1A - C6

● Spacer type

38	Individual SUP spacer
39	Individual EXH spacer

● Series

1	JSY1000
3	JSY3000
5	JSY5000

● Port size (One-touch fittings)

Symbol	P, E port	JSY1000	JSY3000	JSY5000
C4	ø4 One-touch fitting	●	—	—
C6	ø6 One-touch fitting	—	●	—
C8	ø8 One-touch fitting	—	—	●
C10	ø10 One-touch fitting	—	—	●
C12	ø12 One-touch fitting	—	—	●

■ Individual EXH spacer

[With a connector gasket, a base gasket, and two mounting screws]

When valve exhaust affects other stations due to the circuit configuration, this spacer assembly is used for individual valve exhaust.

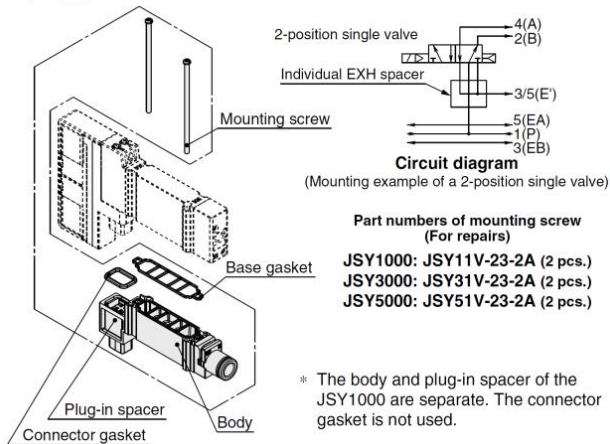

Circuit diagram
(Mounting example of a 2-position single valve)

Part numbers of mounting screw
(For repairs)
JSY1000: JSY11V-23-2A (2 pcs.)
JSY3000: JSY31V-23-2A (2 pcs.)
JSY5000: JSY51V-23-2A (2 pcs.)

* The body and plug-in spacer of the JSY1000 are separate. The connector gasket is not used.

■ **SUP/EXH blocking disk**

[SUP blocking disk]

By inserting the SUP blocking disk in the pressure supply passage of the manifold valve, can provide two different high and low pressure in one manifold.

[EXH blocking disk]

By inserting the EXH blocking disk in the exhaust passage of the manifold valve, can separate the exhaust from the valve so it does not affect the other valves. It can also be used for the manifold for the positive pressure and vacuum mixed manifold. (2 pieces are required to block EA/EB both sides of the EXH.)

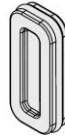

Series	SUP blocking disk	EXH blocking disk
JSY1000	JSY11M-40P-1A	JSY11M-40P-1A
JSY3000	JSY31M-40P-1A	JSY31M-40P-2A
JSY5000	JSY51M-40P-1A	JSY51M-40P-1A

■ **Label for blocking disk**

Label to indicate and confirm on the manifold where the SUP/EXH blocking disk assemblies were inserted. (3 labels of each)

SUP/EXH blocking disk label

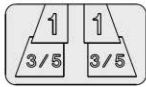

SUP blocking disk label

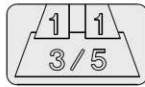

EXH blocking disk label

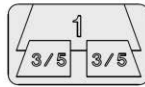

Series	Part no.
JSY1000	
JSY3000	SJ3000-155-1A
JSY5000	

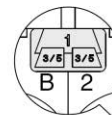

* If the blocking disk is ordered using the manifold specification sheet and ordered at the same time as the manifold, the position where the blocking disk is inserted will be labeled and shipped out.

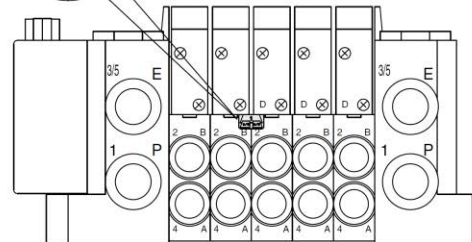

■ **Silencer**

(One-touch fitting connection type)

This silencer can be mounted to the 3/5 (E: EXH) port of the manifold in one step.

* Shipped together with the product

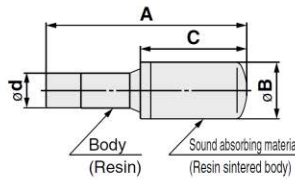

Series (ød)	Model	Effective area	A	B	C
For JSY1000 (ø8)	AN15-C08	20 mm ²	45	13	20
For JSY3000 (ø10)	AN20-C10	30 mm ²	57.5	16.5	30.5
For JSY5000 (ø12)	AN30-C12	41 mm ²	71.5	20	43.5

TROUBLESHOOTING

Should any trouble be found during operation, trace the source of the trouble in the following order and take corrective action.

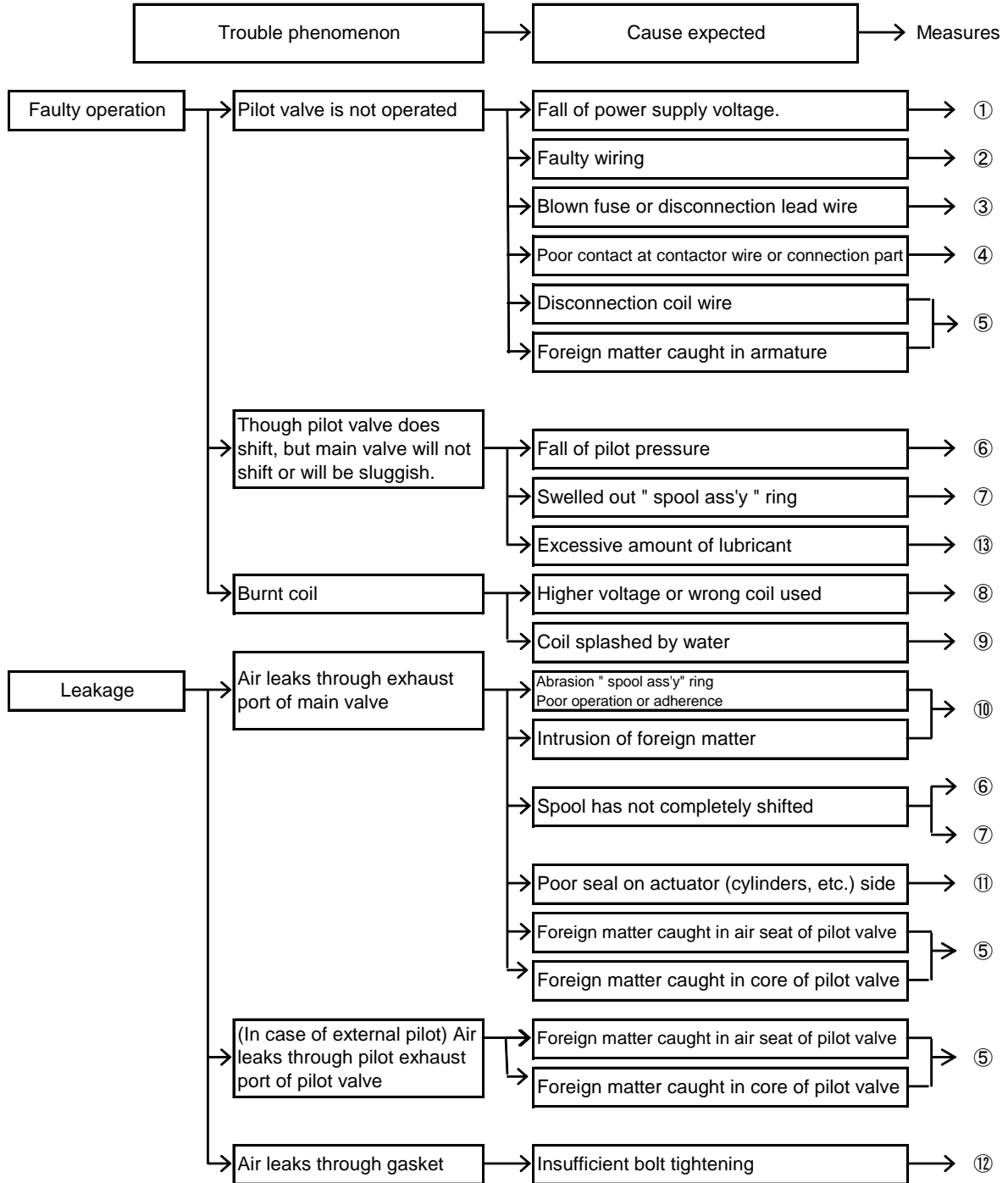

Remedy

No.	Remedy
①	Regulate voltage, so that the voltage at the time of the operation becomes specifications range.
②	Re-wire correctly.
③	Replace part.
④	Replace part or re-wire positively.
⑤	Replace valve.
⑥	Regulate pressure so that pilot pressure will fall within operating pressure range during operation.
⑦	· If wrong oil is used, completely air blow to remove oil, and replace valve. After valve is replaced, use turbine oil class 1 (ISO VG32). · When a large quantity of drain is given and cannot carry out drain omission surely, install either an auto-drain or a dryer. The valve should be replaced.
⑧	Check voltage. Replace valve (pilot valve).
⑨	Protect the valve so that water does not splash the coil.
⑩	In case of intrusion of foreign matter, to remove foreign matter by air blow of piping and then replace valve.
⑪	Repair or replace actuators.
⑫	After stopping air and re-tighten the bolts.
⑬	Reduce the amount of lubricant to the degree that no oil splashes out of the air exhaust (E) port.

If any of followings are carried out, inside of the valve may have some failure. In this case, stop using the valve immediately.

- ① Voltage out of rated voltage has been used.
- ② Oil other than the specified one has been lubricated.
- ③ Lubrication has been stopped intermediately, or lubrication was suspended temporary.
- ④ Water splashed directly. (Except IP65/67 protected product.)
- ⑤ Strong impact was given.
- ⑥ Alien substance such as drain and particle got into. Drain or garbage invaded a valve.
- ⑦ Prohibited way of using the valve which is written at "Precautions" section in this operation manual was carried out excluding above-mentioned.

In addition, in the case of trouble, please send it back to the supplier for repair or replacement.

Revision history

SMC Corporation

4-14-1, Sotokanda, Chiyoda-ku, Tokyo 101-0021 JAPAN

Tel: + 81 3 5207 8249 Fax: +81 3 5298 5362

URL <https://www.smcworld.com>

Note: Specifications are subject to change without prior notice and any obligation on the part of the manufacturer.
© 2020 SMC Corporation All Rights Reserved

No.JSY1000V-OMW0002