



Operation Manual

P r o d u c t N a m e

*Lightweight and Compact Type
Floating Joint*

M o d e l / S e r i e s / P r o d u c t N u m b e r

JT series

SMC Corporation

Contents

- 1. Safety Instructions----- P. 3-7
- 2. Specifications ----- P. 8
- 3. Construction ----- P. 8
- 4. How to Order ----- P. 9
- 5. Dimensions ----- P. 9



Floating Joint Safety Instructions

These safety instructions are intended to prevent hazardous situations and/or equipment damage. These instructions indicate the level of potential hazard with the labels of "Caution," "Warning" or "Danger." They are all important notes for safety and must be followed in addition to International Standards (ISO/IEC)*1), and other safety regulations.

*1) ISO 4414: Pneumatic fluid power -- General rules relating to systems.

ISO 4413: Hydraulic fluid power -- General rules relating to systems.

IEC 60204-1: Safety of machinery -- Electrical equipment of machines .(Part 1: General requirements)

ISO 10218-1992: Manipulating industrial robots -Safety.

etc.



Caution

Caution indicates a hazard with a low level of risk which, if not avoided, could result in minor or moderate injury.



Warning

Warning indicates a hazard with a medium level of risk which, if not avoided, could result in death or serious injury.



Danger

Danger indicates a hazard with a high level of risk which, if not avoided, will result in death or serious injury.

Warning

1. The compatibility of the product is the responsibility of the person who designs the equipment or decides its specifications.

Since the product specified here is used under various operating conditions, its compatibility with specific equipment must be decided by the person who designs the equipment or decides its specifications based on necessary analysis and test results.

The expected performance and safety assurance of the equipment will be the responsibility of the person who has determined its compatibility with the product.

This person should also continuously review all specifications of the product referring to its latest catalog information, with a view to giving due consideration to any possibility of equipment failure when configuring the equipment.

2. Only personnel with appropriate training should operate machinery and equipment.

The product specified here may become unsafe if handled incorrectly.

The assembly, operation and maintenance of machines or equipment including our products must be performed by an operator who is appropriately trained and experienced.

3. Do not service or attempt to remove product and machinery/equipment until safety is confirmed.

1. The inspection and maintenance of machinery/equipment should only be performed after measures to prevent falling or runaway of the driven objects have been confirmed.

2. When the product is to be removed, confirm that the safety measures as mentioned above are implemented and the power from any appropriate source is cut, and read and understand the specific product precautions of all relevant products carefully.

3. Before machinery/equipment is restarted, take measures to prevent unexpected operation and malfunction.

4. Contact SMC beforehand and take special consideration of safety measures if the product is to be used in any of the following conditions.

1. Conditions and environments outside of the given specifications, or use outdoors or in a place exposed to direct sunlight.

2. Installation on equipment in conjunction with atomic energy, railways, air navigation, space, shipping, vehicles, military, medical treatment, combustion and recreation, or equipment in contact with food and beverages, emergency stop circuits, clutch and brake circuits in press applications, safety equipment or other applications unsuitable for the standard specifications described in the product catalog.

3. An application which could have negative effects on people, property, or animals requiring special safety analysis.

4. Use in an interlock circuit, which requires the provision of double interlock for possible failure by using a mechanical protective function, and periodical checks to confirm proper operation.



Floating Joint Safety Instructions

Caution

1. The product is provided for use in manufacturing industries.

The product herein described is basically provided for peaceful use in manufacturing industries. If considering using the product in other industries, consult SMC beforehand and exchange specifications or a contract if necessary. If anything is unclear, contact your nearest sales branch.

Limited warranty and Disclaimer/Compliance Requirements

The product used is subject to the following “Limited warranty and Disclaimer” and “Compliance Requirements”.

Read and accept them before using the product.

Limited warranty and Disclaimer

1. The warranty period of the product is 1 year in service or 1.5 years after the product is delivered, whichever is first.*2)

Also, the product may have specified durability, running distance or replacement parts. Please consult your nearest sales branch.

2. For any failure or damage reported within the warranty period which is clearly our responsibility, a replacement product or necessary parts will be provided.

This limited warranty applies only to our product independently, and not to any other damage incurred due to the failure of the product.

3. Prior to using SMC products, please read and understand the warranty terms and disclaimers noted in the specified catalog for the particular products.

***2) Vacuum pads are excluded from this 1 year warranty.**

A vacuum pad is a consumable part, so it is warranted for a year after it is delivered.

Also, even within the warranty period, the wear of a product due to the use of the vacuum pad or failure due to the deterioration of rubber material are not covered by the limited warranty.

Compliance Requirements

1. The use of SMC products with production equipment for the manufacture of weapons of mass destruction (WMD) or any other weapon is strictly prohibited.

2. The exports of SMC products or technology from one country to another are governed by the relevant security laws and regulation of the countries involved in the transaction. Prior to the shipment of a SMC product to another country, assure that all local rules governing that export are known and followed.

Design / Selection



Warning

(1) Confirm the application.

This product is a shaft coupling for linear reciprocating motion used to absorb slight misalignment of the workpiece and the cylinder during linear motion. It is not a shaft coupling for rotation. Do not use it for an application in which rotation or oscillation is applied.

(2) Use a foot type or flange type bracket to mount a cylinder.

If a clevis type or trunnion type bracket is used, the cylinder shaft will not be fixed and it will be able to rotate. This mounting method, which exceeds the allowable eccentricity and rotation angle of the floating joint, may cause breakage or malfunction of the product.

(3) Confirm the specifications.

Do not operate the product under loading or temperatures outside of specification. This also applies to eccentricity and rotation angle exceeding the allowable value. Failure to use the joint correctly may cause breakage or malfunction of the product.

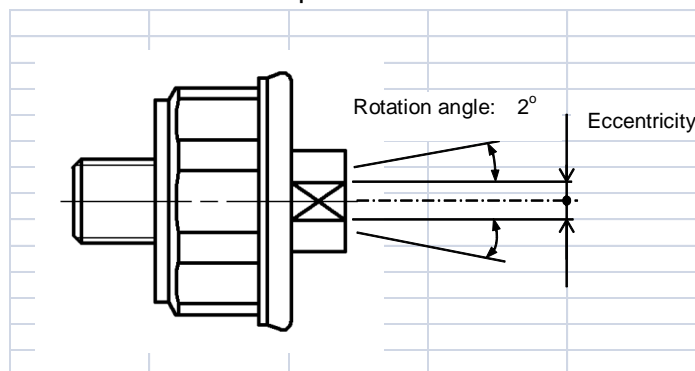

(4) Use cylinder with built-in cushion mechanism.

When a driven object is stopped, ensure the impact force of the object being transferred to the floating joint is prevented by using a cylinder with a built-in cushion mechanism (rubber cushion or air cushion).

To stop the cylinder at the intermediate position, use an external shock absorbing mechanism such as a shock absorber. If the cushion mechanism or the external shock absorbing mechanism is not used, an excessive impact force will be generated when stopping the cylinder and this may cause breakage or malfunction of the product.

(5) Install an external stopper to avoid run-away of the equipment.

If there is a risk of equipment damage or injury in the case of equipment running out of control or dropping of the driven object due to loose connecting screws or excessive impact load, install an external stopper to avoid run-away of the equipment.

(6) Play in the axial direction

JT series has play in the axial direction. (Default: 0.15 mm or less)

When positioning the driven object, avoid the influence of play using a knock pin or external stopper.

Mounting



Warning

(1) Maintenance space

Allow sufficient space for maintenance and inspection.

(2) Operate the socket by hand before mounting to ensure it moves smoothly.

The dust cover may stick to the socket. Move the dust cover at the base of the socket with fingers, or twist the socket right and left gently to free it before mounting.

(3) Tighten the product to the appropriate torque for the screw size using an appropriate tool. In addition, apply a locking adhesive.

When connecting the driven object to the cylinder rod with a floating joint, hold the octagonal and square parts with an appropriate spanner and tighten the floating joint to the appropriate tightening torque. Refer to the table below for the appropriate tightening torque.

The floating joint may be broken or malfunction if parts other than the octagonal or square part are gripped and rotated with pliers or a wrench, or if it is tightened to an excessive torque. As a countermeasure against loosening caused by vibration or other reasons, apply locking adhesive.

Spanner size and tightening torque

Model	Stud (male thread side)		Socket (female thread side)	
	Spanner size	Tightening torque	Spanner size	Tightening torque
JT20	Width: 22 mm	12 Nm	Width: 10 mm	8 to 12 Nm
JT32	Width: 27 mm	24 Nm	Width: 12 mm	15 to 24 Nm
JT40	Width: 36 mm	68 Nm	Width: 17 mm	40 to 68 Nm

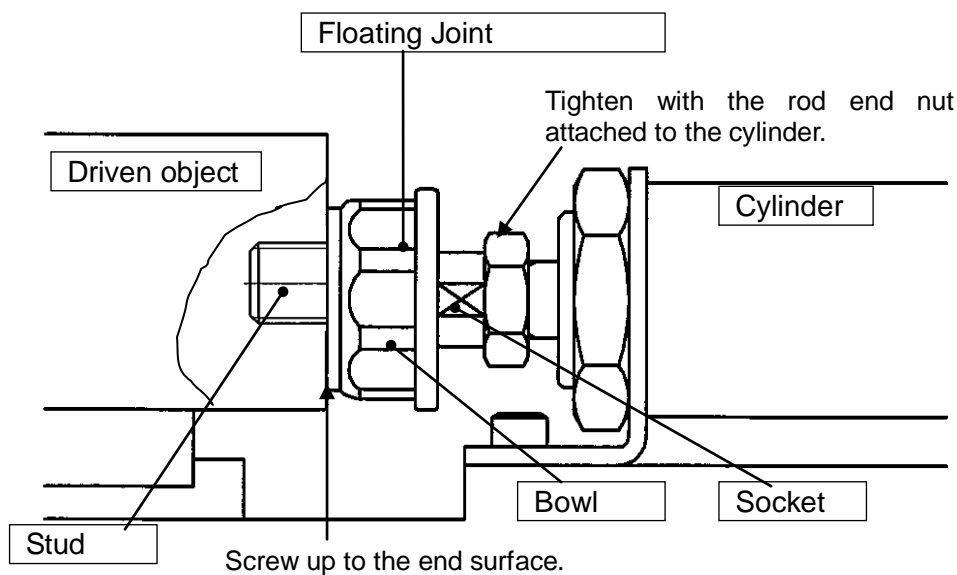

Operating Environment

Warning

- (1) Avoid using in a location where the product could be splashed by liquids such as coolants and water. Also avoid locations where exposed to a large amount of dust or foreign matter.**
If liquid or dust gets inside the floating joint from the gap of the dust cover, it may cause a malfunction. Install a protective cover if the product is directly splashed by liquids or foreign matter can be accumulated.
- (2) Do not use in an atmosphere containing corrosive gases, chemicals, sea water, steam, or where there is direct contact with any of these.**
- (3) Use a protective cover, etc. to shield the product from direct sunlight.**
- (4) Shield the product from radiated heat generated by nearby heat sources.**

Operation

Warning

- (1) Use the product so that the kinetic energy does not exceed the allowable value of the cylinder.**

The JC*M series cylinder is recommended to be used with the JT series. When operating the equipment, adjust the stroke end velocity according to the load so that the kinetic energy is no more than that of the allowable value of the cylinder.

$$\text{Speed when stopping (stroke end velocity)} \cong \text{Average speed} \times 1.4$$

Also, when using cylinders or equipment other than the JC*M series, adjust the stroke end velocity according to the load so that the kinetic energy is no more than that of the allowable value of the JC*M series.

Maintenance

Warning

- (1) Removal of equipment, and supply/exhaust of compressed air**

When equipment is serviced, first confirm that measures are in place to prevent dropping of driven objects and/or equipment running out of control, etc. Then cut the supply pressure and power, and exhaust all compressed air from the system using its residual pressure release function.

When the equipment is to be started again after remounting, first confirm that measures are in place to prevent lurching of actuators, etc., and then confirm that the equipment can operate normally.

- (2) Implement regular inspections as necessary when starting-up, etc. To confirm that there is no loosening of the connection between the driven object and the cylinder.**

When the equipment is operated at high frequency, screws and play in the axial direction can increase and occur easily over time. Make sure to inspect the equipment before starting work to confirm that the screws have not been loosened and the play has not significantly increased.

- (3) If the play in the axial direction becomes larger or abnormal operation is found, replace the product.**

Play in the axial direction of the floating joint will increase over time, even if the product is used constantly. If the amount of play becomes excessive to the application or the operation is inflexible, replace the product itself.

- (4) Confirm that there is no weakening of the rubber cushion within the cylinder or adjustment error of the air cushion.**

If the rubber cushion of the cylinder is weakened or the adjustment of the air cushion is incorrect, an excessive impact force will be generated when the cylinder reaches its end of stroke, this may cause breakage or malfunction of the product. Replace the cylinder if the rubber cushion is weakening or readjust the air cushion if an adjustment error is found.

2. Specifications

- Specifications

Model No.	Nominal screw size	Allowable axial force (N)	Allowable eccentricity (mm)	Rotation angle (°)	Operating temperature range
JT20	M8 x 1.25	220	0.5	+/- 2°	-10 to 70°C
JT32	M10 x 1.25	560	0.5	+/- 2°	
JT40	M14 x 1.5	880	0.75	+/- 2°	

- Applicable cylinders

Model	Note 1) Applicable cylinder		Recommended cylinder
	Tube I.D.	Operating pressure	
JT20	φ20	0.7 MPa or less	JC*M20 (Rod end: Male thread type)
JT32	φ25		JC*M25 (Rod end: Male thread type)
	φ32		JC*M32 (Rod end: Male thread type)
JT40	φ40		JC*M40 (Rod end: Male thread type)

Note 1) Make sure to use cylinder with a built-in cushion mechanism.

3. Construction

- Components

No.	Part name	Material	Note
1	Stud	Carbon steel	Zinc chromated
2	Bowl	Aluminum alloy	Chromated
3	Socket	Carbon steel	Zinc chromated
4	Ring	Rolled steel	Nitriding treatment
5	Slider	Rolled steel	Nitriding treatment
6	Plate	Rolled steel	Zinc chromated
7	Dust cover	Synthetic rubber	

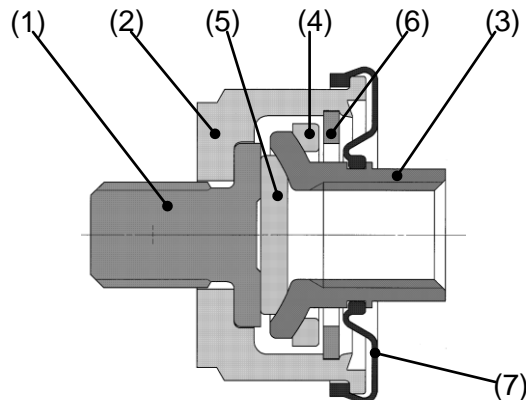

- Spare parts

Part name	Part No.	Applicable model
Dust cover	P215420-07	For JT20
	P215432-07	For JT32
	P215440-07	For JT40

4. How to Order

Symbol	Applicable cylinder	Nominal screw size
20	For $\phi 20$	M8 \times 1.25
32	For $\phi 25$	M10 \times 1.25
	For $\phi 32$	M10 \times 1.25
40	For $\phi 40$	M14 \times 1.5

5. Dimensions

Model	Connecting screw M	A	B	ϕC	ϕD	ϕE	$\square F$	G	Width across flats H	Maximum depth of the thread P	Weight
JT20	M8 x 1.25	19.2	8	11	25.4	23	10	13.7	22	9.5	22g
JT32	M10 x 1.25	23	10	13.4	30.8	28	12	16.3	27	11.5	38g
JT40	M14 x 1.5	29	14	19	40.4	37.4	17	20.3	36	15.5	98 g

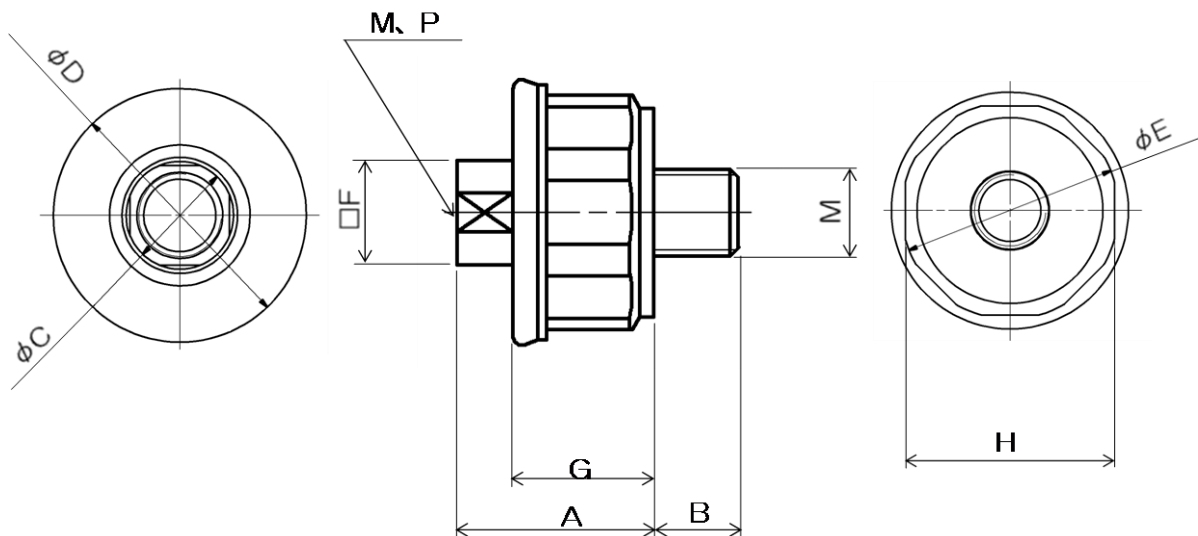

Revision history

SMC Corporation

4-14-1, Sotokanda, Chiyoda-ku, Tokyo 101-0021 JAPAN

Tel: +81 3 5207 8249 Fax: +81 3 5298 5362

URL <http://www.smcworld.com>

NOTE: This manual is subject to change without prior notice.
© 2012 SMC Corporation All Rights Reserved