



Operation Manual

PRODUCT NAME

Card Motor Controller (Serial Communication edition)

Model / Series / Product Number

LATCA Series

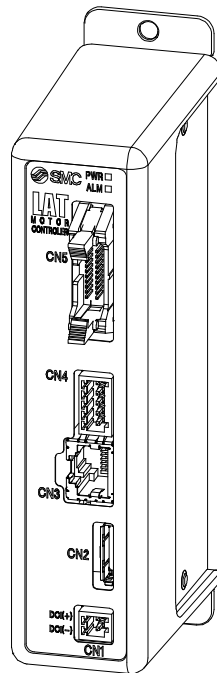

SMC Corporation



About this operation manual

This operation manual summarizes how to operate the Card Motor Controller (LATCA-*, Ver2.5) using the serial communication (RS485).

Refer to "Card Motor Controller (Step Data Input edition)" for information relating to all control modes. When using in Step Data input mode, refer to the "Card Motor Controller (Step Data Input edition)"; when using in pulse input mode, refer to the "Card Motor Controller (Pulse Input edition)"

When communicating using Modbus protocol, refer to the "Card Motor Controller (Modbus communication edition)" operation manual.

Controller history

Use the latest version of the controller.

Function	Controller version (the time in the bracket indicates the schedule for switching)		
	Ver 2.0 (August 2014)	Ver2.1 to Ver2.4 (Sept. 2015)	Ver2.5 (June 2020)
Corresponding card motor	6 types	LAT3M-50 LAT3F-50	LAT3M-50 LAT3F-50
Alarm history count	4 points	4 points	20 inputs
Communication speed	19200bps	2,400bps 9,600bps 19,200bps 38,400bps 57,600bps	2,400bps 9,600bps 19,200bps 38,400bps 57,600bps

1. Safety Instructions	4
2 Summary	6
2.1 Purpose of the Operation Manual.....	6
2.2 Notation	6
2.3 Abbreviations.....	6
3. Scope	7
3.1 Scope	7
4. Hardware Specifications	9
4.1 Input Specifications	9
4.2 Communication Connector Pin Assignment.....	9
4.3 Communication Circuit	9
4.4 Wiring Example.....	10
5. Software Specifications.....	11
5.1 Serial Communication Specification.....	11
5.2 Frame Format	12
5.3 Command List.....	14
5.4 Command Details	15
(1) Step Data Setting Command "EE" Details.....	15
(2) Step Data Save Command "EU" Details	22
(3) Step Data Reflection Command "AB" Details	22
(4) Monitor Command "MO" Details.....	23
(6) Details on Operation Command "OE"Details	26
(7) Alarm History Command "RE"Details.....	28
5.5 Error Code	30
6. Card Motor Controller Operation Examples.....	31
6.1 Basic Settings, I/O Configuration	31
6.2 Step Data Configuration	31
6.3 Operation Data Acquisition	32
6.4 Operation Instruction Method.....	32
6.5 Program Examples	33
(1) Basic Settings.....	33
(2) Communication check.....	33
(3) Step Data Configuration Examples	33
(4) Return to Origin	34

(5) Positioning Operation (Step Data Operation) Example.....	35
(6) Positioning Operation (Direct Operation) Example.....	36
(7) Operation Data Acquisition Example	37
(8) Alarm History Acquisition Example	37
(9) Alarm History Clearance Example	37
7. Option (Separately Sold Products)	38
7.1 Communication cable.....	38
7.2 Branch communication cable.....	39
8. Reference Information.....	41
8.1 Checksum Calculation Procedure	41
8.2. Checksum Calculation Examples	41
8.3 Communication Response Time Guides.....	41
8.4 ASCII Code List.....	42



LATCA Series Controller

1. Safety Instructions

These safety instructions are intended to prevent hazardous situations and/or equipment damage. These instructions indicate the level of potential hazard with the labels of "Caution," "Warning" or "Danger." They are all important notes for safety and must be followed in addition to International Standards (ISO/IEC)*1), and other safety regulations.

*1) ISO 4414: Pneumatic fluid power -- General rules relating to systems.

ISO 4413: Hydraulic fluid power -- General rules relating to systems.

IEC 60204-1: Safety of machinery -- Electrical equipment of machines .(Part 1:General requirements)

ISO 10218-1992:Manipulating industrial robots -Safety.

etc.



Caution

Caution indicates a hazard with a low level of risk which, if not avoided, could result in minor or moderate injury.



Warning

Warning indicates a hazard with a medium level of risk which, if not avoided, could result in death or serious injury.



Danger

Danger indicates a hazard with a high level of risk which, if not avoided, will result in death or serious injury.

Warning

1. The compatibility of the product is the responsibility of the person who designs the equipment or decides its specifications.

Since the product specified here is used under various operating conditions, its compatibility with specific equipment must be decided by the person who designs the equipment or decides its specifications based on necessary analysis and test results.

The expected performance and safety assurance of the equipment will be the responsibility of the person who has determined its compatibility with the product.

This person should also continuously review all specifications of the product referring to its latest catalog information, with a view to giving due consideration to any possibility of equipment failure when configuring the equipment.

2. Only personnel with appropriate training should operate machinery and equipment.

The product specified here may become unsafe if handled incorrectly.

The assembly, operation and maintenance of machines or equipment including our products must be performed by an operator who is appropriately trained and experienced.

3. Do not service or attempt to remove product and machinery/equipment until safety is confirmed.

1. The inspection and maintenance of machinery/equipment should only be performed after measures to prevent falling or runaway of the driven objects have been confirmed.

2. When the product is to be removed, confirm that the safety measures as mentioned above are implemented and the power from any appropriate source is cut, and read and understand the specific product precautions of all relevant products carefully.

3. Before machinery/equipment is restarted, take measures to prevent unexpected operation and malfunction.

4. Contact SMC beforehand and take special consideration of safety measures if the product is to be used in any of the following conditions.

1. Conditions and environments outside of the given specifications, or use outdoors or in a place exposed to direct sunlight.

2. Installation on equipment in conjunction with atomic energy, railways, air navigation, space, shipping, vehicles, military, medical treatment, combustion and recreation, or equipment in contact with food and beverages, emergency stop circuits, clutch and brake circuits in press applications, safety equipment or other applications unsuitable for the standard specifications described in the product catalog.

3. An application which could have negative effects on people, property, or animals requiring special safety analysis.

4. Use in an interlock circuit, which requires the provision of double interlock for possible failure by using a mechanical protective function, and periodical checks to confirm proper operation.



LATCA Series Controller

1. Safety Instructions

Caution

The product is provided for use in manufacturing industries.

The product herein described is basically provided for peaceful use in manufacturing industries.

If considering using the product in other industries, consult SMC beforehand and exchange specifications or a contract if necessary.

If anything is unclear, contact your nearest sales branch.

Limited warranty and Disclaimer/Compliance Requirements

The product used is subject to the following "Limited warranty and Disclaimer" and "Compliance Requirements".

Read and accept them before using the product.

Limited warranty and Disclaimer

1. The warranty period of the product is 1 year in service or 1.5 years after the product is delivered, whichever is first.*2)

Also, the product may have specified durability, running distance or replacement parts. Please consult your nearest sales branch.

2. For any failure or damage reported within the warranty period which is clearly our responsibility, a replacement product or necessary parts will be provided.

This limited warranty applies only to our product independently, and not to any other damage incurred due to the failure of the product.

3. Prior to using SMC products, please read and understand the warranty terms and disclaimers noted in the specified catalog for the particular products.

***2) Vacuum pads are excluded from this 1 year warranty.**

A vacuum pad is a consumable part, so it is warranted for a year after it is delivered.

Also, even within the warranty period, the wear of a product due to the use of the vacuum pad or failure due to the deterioration of rubber material are not covered by the limited warranty.

Compliance Requirements

1. The use of SMC products with production equipment for the manufacture of weapons of mass destruction (WMD) or any other weapon is strictly prohibited.

2. The exports of SMC products or technology from one country to another are governed by the relevant security laws and regulations of the countries involved in the transaction. Prior to the shipment of a SMC product to another country, assure that all local rules governing that export are known and followed.

Caution

SMC products are not intended for use as instruments for legal metrology.

Measurement instruments that SMC manufactures or sells have not been qualified by type approval tests relevant to the metrology (measurement) laws of each country.

Therefore, SMC products cannot be used for business or certification ordained by the metrology (measurement) laws of each country.

2 Summary

2.1 Purpose of the Operation Manual

This operation manual discloses the serial communication specifications for the Card Motor controller (LATCA-*, Ver 2.5).

2.2 Notation

Unless explicitly stated otherwise, this operation manual follows the notation detailed below.

- (1) Values are written in big-endian byte order.
- (2) Values are generally written in decimal, however those ending with "h" are in hexadecimal, and those ending in "b" in binary.

2.3 Abbreviations

This manual uses the following abbreviations.

GUI	: Graphical User Interface
I/O	: Input/Output
I/F	: Interface
MSB	: Most Significant Bit
ASCII	: American Standard Code for Information Interchange
BCD	: Binary-coded decimal
MFC	: Microsoft Foundation Class
API	: Application Programming Interface
PLC	: Programmable Logic Controller
PC	: Personal computer
COM	: Computer on Module
RS-485	: Recommended Standard 485
USB	: Universal Serial Bus

3. Scope

3.1 Scope

This operation manual applies only for communication between up to 16 Card Motor controllers (LATCA-, Version 2.5) and a communication device such as a PLC other than the Card Motor Controller Configuration Software, using the functions as described below.

(1) Step Data Configuration

The following parameters may be configured.

- Operation mode selection (positioning/pushing)
- Movement mode (ABS/REL)
- Target position
- Positioning time
- Speed
- Acceleration
- Deceleration
- Thrust setting value
- Load mass
- Pushing speed
- Positioning width
- Threshold
- Area range

(2) Operation Data Acquisition

The following internal Card Motor controller operation data is acquired.

- I/O data
- Positioning data
- Speed data
- Equivalent thrust value data
- Target position
- Step Data no. executed

(3) Step Data Operation

By employing pre-set Step Data, operation instructions will be given from the upper-level device such as a PLC without using parallel I/O signals input.

- * When setting Step Data, turn the power supply to the Card Motor off and ensure a Return to Origin is performed after the Step Data configuration is complete.

(4) Direct Operation

By employing Direct Operation Step Data, operation instructions will be given from the upper-level device such as a PLC without using parallel I/O signals input.

- *Direct operation step-data cannot be saved internally to the Card Motor controller. Return to origin operation is not required after setting direct operation step-data. The set step-data operation pattern will be reflected when executing the OE operation command.

- Differences between Step Data operation and direct operation:

Configuration of stepdata in Step Data operation and direct operation have the following differences.

Criteria	Step Data operation	Direct operation
Power supply to Card Motor turned OFF when settings are changed.	Yes	No
Step data saved/processed after each change in settings	Yes	No
Return to Origin to be executed after setting changes	Yes	No
Configuration data maintained even if the power supply is turned off	Saved	Not saved

(5) Acquisition and clearance of alarm history

The alarm history saved in the controller will be cleared / acquired.

 **Caution**

Please use the controller configuration software to pre-set the basic controller settings (see below).

1. Input type (step data input type/pulse input type)
2. Card Motor part number
3. Return to Origin method
4. Step Data inputmethod
5. Card Motor mounting orientation
6. Controller ID configuration (factory setting = 1)
7. Output signal function selection
8. Communication speed

When the controller is set to 'pulse input type', operation cannot be performed via the serial communication. Some step data settings, acquisition of operation information and alarm history only are available.

Please refer to **5.3 Command list** for the functions which are available with pulse input type.

4. Hardware Specifications

4.1 Input Specifications

Based on the RS485 (2-wire type)

4.2 Communication Connector Pin Assignment

Connector used: Hirose Electronics 「TM11R-5M2-88」

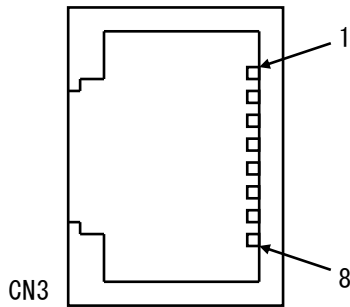

Terminal no.	Function	Description
1	NC	Not connected
2	NC	Not connected
3	SD +	Connect + signal lead ^{Note1)}
4	SD -	Connect - signal lead ^{Note1)}
5	NC	Not connected
6	NC	Not connected
7	NC	Not connected
8	NC	Not connected

Note 1) Please read the operation manual before connecting modules.

If the function is written as A/B, please connect +/- for the signals.

As this product is a 2-wire type, "TXD and RXD" are written together as "SD"

4.3 Communication Circuit

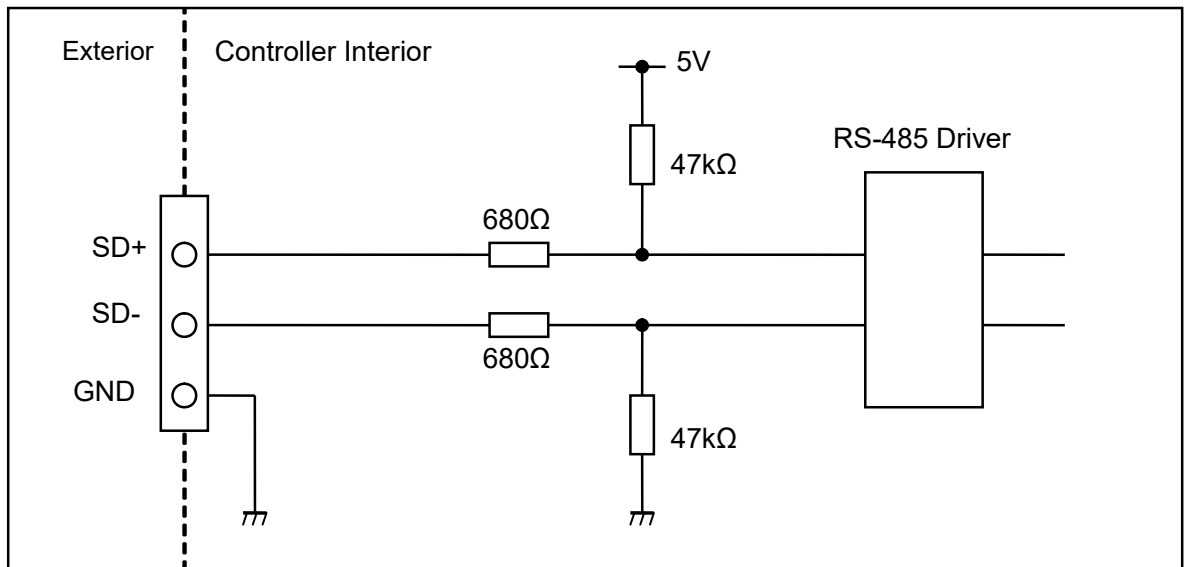

Note 1) There is no terminal resistor built into the controller communication circuit.

4.4 Wiring Example

An example of wiring when connecting one controller to upper level equipment such as a PLC using an optional communication cable (LATH6-*) is shown below.

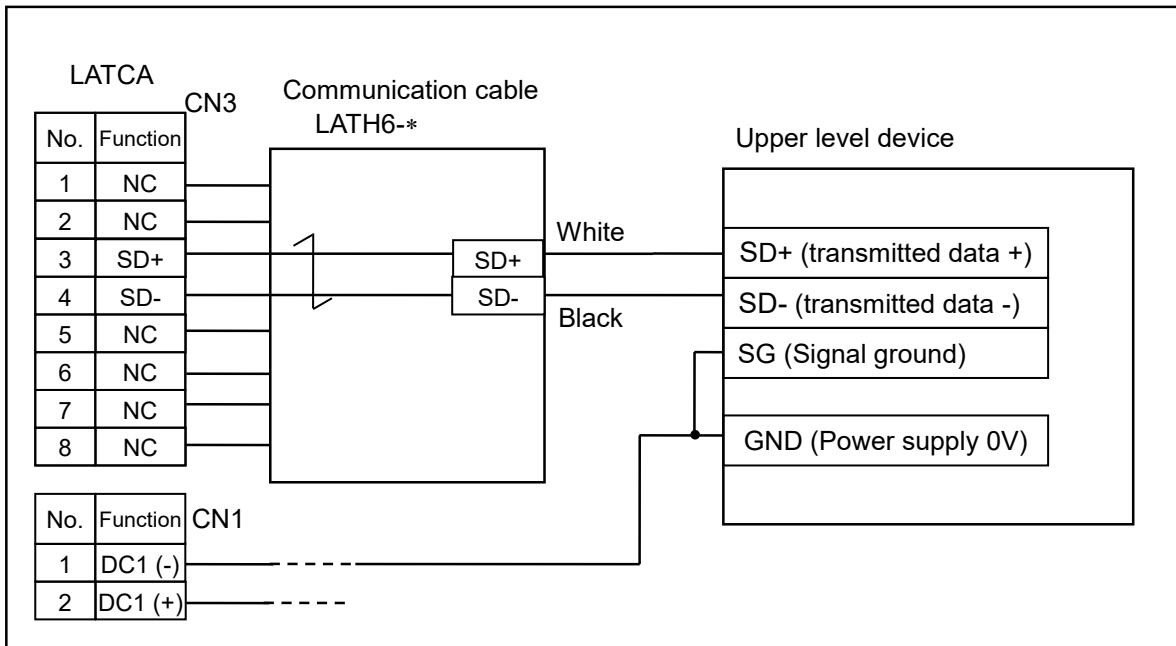

An example of wiring when multiple controllers (e.g. 3pcs.) using optional branch communication cables (LATH7-*), branch connector (LEC-CGD), branch-to-branch cables (LEC-CG2-*) and communication cable (LEC-CG1-*) are connected to upper level equipment such as a PLC is shown below.

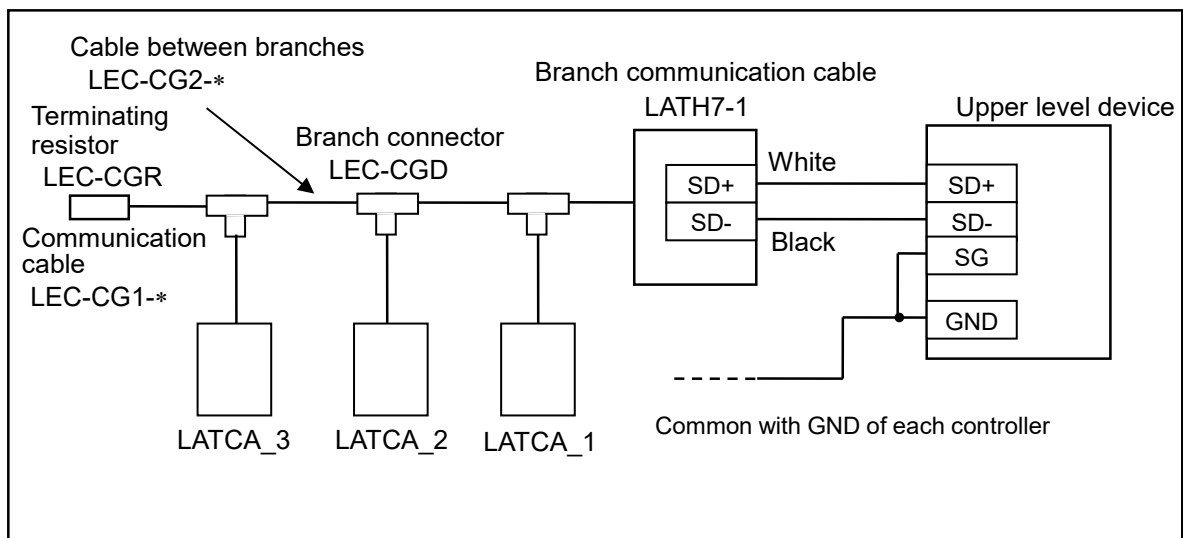

Warning

The power supply 0V of all controllers for communication and that of the master should be the same.

Turn OFF the power supply before connecting and removing the connector.

Otherwise the controller may be damaged.

5. Software Specifications

5.1 Serial Communication Specification

The LATCA specific (command type) protocol is shown below.

Criteria	Description	
Protocol	Specific to LATCA	
Communication data	ASCII hex	
Node type	Slave (controller)	
Error Check	None	
Frame size	Variable length; 128 bytes maximum	
Communication mode	RS-485; asynchronous mode	
	Communication speed	2,400bps 9,600bps 19,200bps (Default value) 38,400bps 57,600bps
	Data bits	8bits
	Parity	Even parity
	Stop bit	1bit
	Flow control	None

5.2 Frame Format

The frame formats used in serial communication are listed below.

(1) Frame Format

(i) Requirements (upper level equipment such as PLC → Card Motor controller)

Start Code	ID ^{Note1)}	Space	Command	Space	Parameter	Check Sum	End Code
1 byte	2 bytes	1 byte	2 bytes	1 byte	0 to 57 bytes	2 bytes	2 bytes
:	"01"- "FF"	20h	Command	20h	Depending on command	LRC	CR, LF

Note1) This is the controller ID set in the Card Motor controller (initial setting = 1).

ID configuration example)

ID 1 : "01"

ID15 : "0F"

ID16 : "10"

Note2) Insert a space (20h) between the ID and the command, and between the command and the parameter.

(ii) Response (Card Motor controller → upper-level device such as PLC)

(a) Normal response

Start Code	ID ^{Note1)}	Command	Result	Response Data	Check Sum	End Code
1 byte	2 bytes	2 bytes	2 bytes	0 to 55 bytes	2 bytes	2 bytes
:	"01"- "FF"	Sent command received.	"OK"	Depending on command	LRC	CR, LF

Note 1) This is the controller ID set in the Card Motor controller (initial setting = 1).

ID configuration example)

ID 1 : "01"

ID15 : "0F"

ID16 : "10"

(b) Irregular response

Start Code	ID ^{Note1)}	Command	Result	Error details	Check Sum	End Code
1 byte	2 bytes	2 bytes	2 bytes	2 bytes	2 bytes	2 bytes
:	"01"- "FF"	Sent command received	"NG"	Refer to "5.5 Error Code"	LRC	CR, LF

Note 1) This is the controller ID set in the card motor controller (initial setting = 1).

ID configuration example)

ID 1 : "01"

ID15 : "0F"

ID16 : "10"

(2) Guard processing of received frames

If the ASCII code is broken as a result of noise in the frame received and inaccurate data is mixed, an "NG" will be sent. If only inaccurate data is received, by discarding of the received data, the frame received can be protected. Inaccurate data refers to data other than the ASCII data below.

- (a) Alphabet (upper/lower case)
- (b) Special characters (BS, space, TAB, comma, full stop, hyphen)
- (c) Line-break code (CR+LF)

(3) ID

When communication is established between the Card Motor controller and upper level device such as a PLC, a request will be received and a response will be sent only when the pre-set Card Motor controller ID matches with the controller ID in the requested message frame.

If the controller ID in the communication data differs to the controller ID set in the Card Motor controller, the received communication data will be discarded and no response will be made.

 **Caution**

Please use the unique controller IDs for each controller within the same serial communication network.

The use of same IDs may result in interference in response data.

5.3 Command List

A list of possible commands is detailed below.

When the controller is set to 'pulse input type', the available functions are limited.

Command	Parameter	Meaning	Pulse input
EE	INDEX1 INDEX2 DATA	(1) Reading Step Data The INDEX 2 parameter related to the Step-Data no. in INDEX 1 will be read. (2) Step Data configuration ^{Note1) 2) 3)} The INDEX 2 parameter related to the step-data no. in INDEX 1 will be configured. ^{Note1)}	○
EU	None	All parameters set using an EE command are saved simultaneously. ^{Note1) 2) 3)}	○
AB	None	All parameters saved using the EU command are reflected simultaneously. ^{Note1) 2) 3)}	○
MO	None	I/O state, current card motor position, speed, equivalent thrust force value, target position and Step-Data no of current operation will be read.	○
MD	MODE	This changes the controller operation mode from parallel I/O to serial communication mode. (Parallel I/O operation mode using I/O signals will be activated when the power supply is turned on).	×
OE	STEP ENABLE ACTION	Card Motor operation instructions through serial communication (Serial I/O Operation). ^{Note1),Note4)}	×
RE	CLEAR	Acquisition and clearance of alarm history	○

○ : Available

× : N/A

Note1) Step Data no. 1-15 configured using the EE command will not be reflected until the EU or AB commands are executed. These Step Data cannot be used with OE command based operation instructions.

Step Data no. 20 configured using the EE command does not require execution of the EU or AB commands. This Step Data can be used with OE command based operation instructions.

Note2) When configuring and reflecting Step Data, execute the EE → EU → AB commands in that order.

Note3) When configuring and reflecting StepData, ensure the power to the Card Motor is turned OFF.

If the EU or AB commands are executed while power is ON to the Card Motor, unexpected malfunction may occur.

Note4) Please execute the OE command after changing the MODE to 1 (serial I/O operation) using the MD command. When set to MODE 0 (parallel I/O operation, no operation will be performed even if the OE command is executed.

5.4 Command Details

(1) Step Data Setting Command "EE" Details

Step Data values identified as "INDEX1" or "INDEX2" will be read.

Step Data values identified as "INDEX1" or "INDEX2" can also be set.

Please see the parameter table below for details.

(i) Required Format

- Data read

Start Code	ID	Space	Command	Space	INDEX1	Space	INDEX2	Check Sum	End Code
:	"01"- "FF"	20h	"EE"	20h	"3"- "17" "22"	20h	"0"- "14"	LRC	CR,LF

- Data Setting

Start Code	ID	Space	Command	Space	INDEX1	Space	INDEX2	Space	DATA	Check Sum	End Code
:	"01"- "FF"	20h	"EE"	20h	"3"- "17" "22"	20h	"0"- "14"	20h	ASCII hex	LRC	CR, LF

- DATA (Configuration Data)

Please set data value as a multiple of the configuration unit. Values smaller than the configuration unit will be discarded.

(ii) Response Format

- Data read

(a) Normal response

Start Code	ID	Command	Result	Response Data (Saved Data)	Check Sum	End Code
:	"01"- "FF"	"EE"	"OK"	ASCII hex	LRC	CR, LF

(b) Irregular response

Start Code	ID	Command	Result	Error details	Check Sum	End Code
:	"01"- "FF"	"EE"	"NG"	Refer to "5.5 Error Code"	LRC	CR, LF

- Data Setting

(a) Normal response

Start Code	ID	Command	Result	Check Sum	End Code
:	"01"- "FF"	"EE"	"OK"	LRC	CR, LF

(b) Irregular response

Start Code	ID	Command	Result	Error details	Check Sum	End Code
:	"01"- "FF"	"EE"	"NG"	Refer to "5.5 Error Code"	LRC	CR, LF

- DATA (Saved Data)

Data will be sent as a value to 5 decimal points.

Response Data	0.00000 to 60000.00000
---------------	------------------------

E.g. 1) When reading Step Data No. 1: Movement Time

Command sent ":EE 3 1D2 (D2 is the checksum)

Data Sent ":EEOK0.030008B" (8B is the checksum)

E.g. 2) When reading Step Data No. 10: Target Position

Command sent ":EE 12 0A3"(A3 is the checksum)

Data sent ":EEOK5000.00000F9" (F9 is the checksum)

Parameter List

INDEX1		INDEX2		DATA	
Parameter Value	Description	Parameter Value	Description	Configuration Unit	Value Range
0-2	-	Unavailable			
3	Step Data No. 1 (Step Data No. 0 ^{Note6})	0	Target Position [μm] ^{Note 1)}	1	Note 1)
		1	PositioningsTime [s]	0.01	0 to 60
		2	Speed [mm/s]	1	0 to 400
		3	Acceleration [mm/s ²]	1	0 to 60000
		4	Deceleration [mm/s ²]	1	0 to 60000
		5	PushingSpeed [mm/s] ^{Note2)}	1	1 to 20, 32768 to 32788
		6	Thrust Setting Value ^{Note 3)}	0.1	More than 1 ^{Note 3)}
		7	Load Mass [g]	50	0,50,100 to 1000
		8	MovementMode (0:ABS, 1:REL)	1	0 , 1
		9	ThresholdForceValue	0.1	0.1 to 5
		10	Positioning width [μm]	1	0 to Note1)
		11	AREA A Position 1 [μm] ^{Note1)}	1	0 to Note1)
		12	AREA A Position 2 [μm] ^{Note1)}	1	0 to Note1)
		13	AREA B Position 1 [μm] ^{Note1)}	1	0 to Note1)
		14	AREA B Position 2 [μm] ^{Note1)}	1	0 to Note1)
		15	Unused	-	-
4	Step Data No. 2 (Step Data No. 1 ^{Note6})	0-15	Same as above.	Same as above.	
5	Step Data No. 3 (Step Data No. 2 ^{Note6})	0-15	Same as above.	Same as above.	
6	Step Data No. 4 (Step Data No. 3 ^{Note6})	0-15	Same as above.	Same as above.	
7	Step Data No. 5 (Not used.)	0-15	Same as above.	Same as above.	
...	
17	Step Data No. 15 (Not used.)	0-15	Same as above.	Same as above.	
18-21	Step Data No. 16-19 (Not used.)	Unavailable			
22	Step Data No. 20 ^{Note4)} (Not used.)	0-15	Same as Step Data No. 1-15		

Note 1: The maximum value is the same as for the Card Motor maximum stroke [μm].

(e.g. Maximum value for the LAT3-10: 10000 [μm])

The minimum values vary depending on the movement mode as described below.

Minimum value in REL operation: Card Motor stroke [μm] x -1

(e.g. Minimum value for the LAT3-10: -10000 μm)

Minimum value in ABS operation: 0

Note 2: Refer to the following examples for how to set the pushing speed.

For "Pushing Speed" use 32768 as base value, and add speed in [mm/s]. If no value or a value equal to or less than 32768 is input, the pushing operation will not be performed, even if a thrust setting value has been input.

- Step Data No. 1 (in Pulse Input Mode, corresponding Step Data is No. 0):

The controller uses the pushing speed value set in Step Data No. 1 (Step Data No. 0) as the speed value for the Return to Origin operation.

(Example) When Step Data No. 1 is used for a positioning operation:

Recommended set value

Set value for pushing speed = **6** (Thus, positioning speed of Return to Origin: 6 mm/s,

Pushing speed for Step Data No. 1 positioning operation: 0 mm/s)

(Example) When Step Data No. 1 (Step Data No. 0) is used for a pushing operation and the speed is set to 6 mm/s:

Recommended set value

Set value for pushing speed = **32774** (Thus, Return to Origin speed and Pushing speed for Step Data No.1 (Step Data No. 0) pushing operation: 6 mm/s)

Caution

Do not set pushing speed value for Step Data No. 1 (Step Data No. 0 in Pulse Input Mode) to "0" or "32768".

If those values are input, the Return to Origin operation cannot be performed as the speed becomes 0 mm/s.

- Step Data No. 2 and higher (in Pulse Input Mode, corresponding Step Data is No. 1 and higher):

(Example) For positioning operation:

Recommended set value

Set value for pushing speed = **32768** (Thus, pushing speed: 0 mm/s)

(Example) Pushing operation with set speed of 6 mm/s:

Recommended set value

Set value for pushing speed = **32774** (Pushing speed: 6 mm/s)

Note 3: Maximum values differ depending on the Card Motor model.

(LAT3*-10: 5.0, LAT3*-20: 4.8, LAT3*-30: 3.9, LAT3*-50: 2.0)

Note 4: Step Data 20 is used in direct operation.

Note 5: If the Target Position exceeds the stroke range, the Card Motor operation speed is over 400mm/s, or any other impossible value is set, during the operation "Step Data error" will occur.

Please set values as appropriate.

Note 6: Step Data numbers in brackets are valid in Pulse Input mode.

Caution

Do not specify values other than between 3, 17 and 22 for INDEX1, and 0 and 14 for INDEX2.

Alarms may occur, or the card motor may malfunction unexpectedly.

If an address or flag has been written in error or the Card Motor makes an unexpected movement, initialize the LATCA controller using the controller configuration software to reset the controller to factory default settings.

When configuring/reflecting Step Data, please transmit the commands in the order of EE→EU→AB.

Step Data will not be changed by only sending an EE command.

Configure the contents of Step Data No.20 before using Direct Operation.

The content is reset when it is turned off.

Set the Load Mass and Speed for Return-to-Origin at those for Step Data No. 1.

(iii) Parameter Description

Parameter Name	Description
Step Data	The Step Data No. to be read and configured is defined.
Target Position	Configure either the target position or the thrust starting position.
PositioningTime	<p>Configures the positioning time in which the target position is to be reached. In "Step Data input" mode only "CycleTimeEntryMethod" can be used.</p> <div style="border: 1px solid black; padding: 5px;"> <p style="text-align: center;">⚠ Caution</p> <p>Depending on the order in which Step Data is read, certain conditions may mean that the commanded operations cannot be executed.</p> <p>In this case an alarm will be generated, and the operation will not be completed. Please set according to the customer operation condition.</p> </div>
Speed	<p>Configures the movement speed to either the Target Position or the thrust starting position. In "Step Data input" mode only "Speed Entry Method" can be used.</p> <div style="border: 1px solid black; padding: 5px;"> <p style="text-align: center;">⚠ Caution</p> <p>If parameters which cannot be executed are set, operation may not be able to be completed according to the settings.</p> <p>Acceleration and deceleration settings are detailed below.</p> </div>
Acceleration	<p>Setting the movement acceleration. In "Step Data input" mode only "Speed Entry Method" can be used.</p>
Deceleration	<p>Setting the movement deceleration. In "Step Data input" mode only "Speed Entry Method" can be used.</p>
PushingSpeed	<p>Configuration of movement speed for thrust control. Pushing speed configuration in Step Data no. 1 will be used for the Return to origin operation.</p>
Thrust Setting Value	<p>Sets the maximum controlled thrust force.</p> <div style="border: 1px solid black; padding: 5px;"> <p style="text-align: center;">⚠ Caution</p> <p>The thrust setting value is for reference only.</p> <p>Be sure to check the operation sufficiently before setting and using the card motor.</p> </div>
Load Mass	<p>Sets the weight of the work-piece to be applied to the Card Motor. Load Mass configuration in Step Data No. 1 will be used in the Return to origin operation.</p> <div style="border: 1px solid black; padding: 5px;"> <p style="text-align: center;">⚠ Caution</p> <p>The selected load mass is for reference only.</p> <p>Be sure to check the operation sufficiently before setting and using the card motor.</p> </div>

Parameter Name	Description						
Movement Mode	<p>Target position coordinates will be set.</p> <table border="1" data-bbox="416 239 1433 488"> <thead> <tr> <th data-bbox="416 239 657 293">Movement Mod</th> <th data-bbox="657 239 1433 293">Details</th> </tr> </thead> <tbody> <tr> <td data-bbox="416 293 657 392">ABS</td> <td data-bbox="657 293 1433 392">The target position will be set as an absolute coordinate with the Card Motor Origin point used as a reference point.</td> </tr> <tr> <td data-bbox="416 392 657 488">REL</td> <td data-bbox="657 392 1433 488">The target position will be set as a relative coordinate with the current position used as a reference point.</td> </tr> </tbody> </table>	Movement Mod	Details	ABS	The target position will be set as an absolute coordinate with the Card Motor Origin point used as a reference point.	REL	The target position will be set as a relative coordinate with the current position used as a reference point.
Movement Mod	Details						
ABS	The target position will be set as an absolute coordinate with the Card Motor Origin point used as a reference point.						
REL	The target position will be set as a relative coordinate with the current position used as a reference point.						
Threshold Force Value	<p>Specifies the conditions when to output the INF signal.</p> <p>The INF signal will turn ON when the thrust force generated by the Card Motor exceeds the Threshold Setting Value.</p> <p>The Threshold Force Value can be configured independent of the Thrust Setting Value, meaning that if a Thresold Force Value higher than the Thrust Setting Value is entered, the INF signal will not turn ON.</p>						
Positioning width	<p>Configures the range from the Target Position which outputs the INP signal.</p>						
AREA A Position 1	<p>Configures the table position range within which the AREA signal will be output.</p> <p>The AREA signal is output for both the AREA A and AREA B set configuration.</p> <p>Set as $AREA\ 1 \leq AREA\ 2$.</p>						
AREA A Position 2							
AREA B Position 1							
AREA B Position 2							

(2) Step Data Save Command "EU" Details

Use after executing Step Data setting comand "EE".

(i) Required Format

Start Code	ID	Space	Command	Check Sum	End Code
:	"01"- "FF"	20h	"EU"	LRC	CR, LF

(ii) Response Format

(a) Normal response

Start Code	ID	Command	Result	Check Sum	End Code
:	"01"- "FF"	"EU"	"OK"	LRC	CR, LF

(b) Irregular response

Start Code	ID	Command	Result	Error details	Check Sum	End Code
:	"01"- "FF"	"EU"	"NG"	Refer to "5.5 Error Code"	LRC	CR, LF

Caution

Execute the EU and AB command when the SVON signal is OFF in parallel I/O operation or when the ENABLE of the OE command is 0 in serial I/O operation.

Otherwise the Card Motor may malfunction unexpectedly.

(3) Step Data Reflection Command "AB" Details

Use after executing the Step Data save command "EU".

(i) Required Format

Start Code	ID	Space	Command	Check Sum	End Code
:	"01"- "FF"	20h	"AB"	LRC	CR, LF

(ii) Response Format

(a) Normal response

Start Code	ID	Command	Result	Check Sum	End Code
:	"01"- "FF"	"AB"	"OK"	LRC	CR, LF

(b) Irregular response

Start Code	ID	Command	Result	Error details	Check Sum	End Code
:	"01"- "FF"	"AB"	"NG"	Refer to "5.5 Error Code"	LRC	CR, LF

(4) Monitor Command "MO" Details

Execute the Return to Origin operation before using the Monitor Command.

If the Monitor Command is input before the Return to Origin operation, correct information may not be acquired.

(i) Required Format

Start Code	ID	Space	Command	Check Sum	End Code
:	"01"- "FF"	20h	"MO"	LRC	CR, LF

(ii) Response Format

(a) Normal response

Start Code	ID	Command	Result	I/O Data	Position Data	Speed Data	Thrust Data	Target position	Step Data No.	Check Sum	End Code
:	"01"- "FF"	"MO"	"OK"	4 bytes	8 bytes	4 bytes	2 bytes	8 bytes	2 bytes	LRC	CR, LF

(b) Irregular response

Start Code	ID	Command	Result	Error details	Check Sum	End Code
:	"01"- "FF"	"MO"	"NG"	Refer to "5.5 Error code"	LRC	CR, LF

(iii) Monitor Details

(a) I/O data

In binary, when I/O is ON "1" is displayed, and "0" when it is OFF, this will then be converted to ASCII and sent.

The input signal: Upper line is for the Step data input type and lower line is for the Pulse input type.

Available Signal	Reserved			INP	Origin Note1)	PLS	OUT 1	OUT 0	ALARM	BUSY	DRIVE SETUP	SVON SVON	IN 3 TL	IN 2 CLR	IN 1 IN 1	IN 0 IN 0
Condition	0	0	0	1b	1b	1b	1b	1b	1b	1b	1b	1b	1b	1b	1b	1b
ASCII hex	"0000" to "1FFF"															

Note 1) Changes to "1" after completion of the Return to Origin operation.

E.g) Sent data: 0A9Ch ⇒ 0000, 1010, 1001, 1100b

I/O state: After completion of the Return to Origin, during OUT1, ALARM signal output, during SVON, IN3, IN2 signal output

(b) Positioning Data (encoder count value)

The current position data is sent as an encoder count value.

Please calculate the position by multiplying the encoder resolution of the Card Motor model being used.

As a reference point, 0mm is set as a count value of 1,000,000.

The count decreases each time the position is moved from 0 mm position toward the opposite side to the connector.

Binary digit (decimal)	900,000 to 1,100,000
ASCII hex	"000DBBA0" to "0010C8E0"

Formula Example) LAT3-10 (encoder resolution: 0.03mm)

Data response: "000F418C" ⇒ 999,820count

CardMotor table position: (1,000,000-999,820) x 0.03 mm= 5.4 mm

(c) Speed data mm/s

Responds with data (absolute values) on the current Card Motor movement speed. Direction is not taken into consideration.

Binary digit (decimal)	0 to 1000
ASCII hex	"0000" to "03E8"

(d) Equivalent thrust value data

A value 10x that of the equivalent thrust force value will be sent.

Binary digit (decimal)	0 to 50
ASCII hex	"00" to "32"

(e) Target position (encoder count value): This item is valid for Pulse Input Type control signal mode only.

The target position data is sent as an encoder count value.

Count value 1,000,000 has been fixed for 0 mm as a reference point.

The 0 mm position is set to 1,000,000 count as a reference.

The count decreases each time the position is moved from 0 mm position toward the opposite side to the connector.

Binary digit (decimal)	900,000 to 1,100,000
ASCII hex	"000DBBA0" to "0010C8E0"

Formula example) LAT3-10 (encoder resolution: 0.03 mm)

Reply data: "000F418C" ⇒ 999,820 counts

Card motor table position: (1,000,000-999,820) x 0.03 mm= 5.4 mm

(f) Step Data number executed

Step Data number being executed sent.

Applicable numbers are as follows.

- For Step Data Input Type control signal mode
 - 0: Not executed
 - 1-15: Step Data Operation Step Data number
 - 20: Direct Operation
 - 99: Return to Origin position
- For Pulse Input Type
 - 0-3 : Step data No
 - 99 : When returned to origin

Binary digit (decimal)	0 to 99
ASCII hex	"00" to "63"

(5) Operation Instructions Method Change Command "MD" Details

This changes the controller operation mode from parallel I/O to serial communication mode.

(Parallel I/O operation mode using I/O signals will be activated when the power supply is turned on).

When using this command, after transitioning the CardMotor controller to serial communication operation mode, execute the "OE" command.

- Parallel I/O operation: Operation will follow operation instructions input using I/O signals. (Power ON)

-Serial I/O operation: Parallel I/O input will not be accepted.

Parallel I/O will be output in the same way as in Parallel I/O operation.

(i) Required Format

Start Code	ID	Space	Command	Space	MODE	Check Sum	End Code
:	"01"- "FF"	20h	"MD"	20h	"0","1"	LRC	CR, LF

(ii) Response Format

(a) Normal response

Start Code	ID	Command	Result	Check Sum	End Code
:	"01"- "FF"	"MD"	"OK"	LRC	CR, LF

(b) Irregular response

Start Code	ID	Command	Result	Error details	Check Sum	End Code
:	"01"- "FF"	"MD"	"NG"	Refer to "5.5 Error Code"	LRC	CR, LF

(iii) Parameter List

MODE		
Parameter Value	Description	Function
0	Parallel I/O Operation	Operation will follow operation instructions input using parallel I/O signals.
1	Serial I/O Operation	Command operation instructions through serial communication followed.

(iv) Precautions when executing the Operation Instructions Method Change Command [MD]

- The controller will automatically start up in I/O operation mode when power is switched on to the controller. If the power supply to the controller is reset, please re-enter serial I/O operation using the "MD" command.
- Perform the Return to Origin operation before operating the Card Motor after changing the controller operation instruction mode.
- When transitioning from serial I/O operation mode to parallel I/O operation mode, the parallel I/O signals being entered will be disabled. After transitioning to parallel I/O operation mode, please complete input the parallel I/O signals again.
- If the controller is configured to Pulse Input mode, serial I/O operation cannot be performed. Use the configuration software to switch between Step Data Input mode and Pulse Input mode.
- Use the "MD" command after turning off the power to the Card Motor (Sending ENABLE = "0" by "OE" command).

(6) Details on Operation Command "OE"Details

To be able to use this command, the controller must be set to serial I/O operation mode through the "MD" command in advance. This command should also be used in both Step Data and Direct Operation modes. Select the desired Step Data number and send ACTION "0", once ACTION "1" is send, please execute the Step Data selected in STEP.

Before operating in direct operation mode, use the "EE" command to set Step Data No. 20 parameters in advance. Direct operation will run according to the data configured to Step Data No. 20.

(i) Required Format

Start Code	ID	Space	Command	Space	STEP	Space	ENABLE	Space	ACTION	Check Sum	End Code
:	"01"- "FF"	20h	"OE"	20h	"0"- "15" ,"20"	20h	"0", "1"	20h	"0", "1"	LRC	CR, LF

(ii) Response Format

(a) Normal response

Start Code	ID	Command	Result	Check Sum	End Code
:	"01"- "FF"	"OE"	"OK"	LRC	CR, LF

(b) Irregular response

Start Code	ID	Command	Result	Error details	Check Sum	End Code
:	"01"- "FF"	"OE"	"NG"	Refer to "5.5 Error Code"	LRC	CR, LF

(iii) Parameter Description

STEP		ENABLE		ACTION	
Parameter Value	Description	Parameter Value	Description	Parameter Value	Description
0	Return to Origin	0	Card Motor power OFF	0	Maintain Current Position
1 to 15	Step Data Operation Step Data No.	1	Card Motor power ON	1	Operation Start
20	Direct Operation				

(iv) Operation and Parameter Examples

Operation	Parameter Value		
	STEP	ENABLE	ACTION
Power supply to Card Motor turned ON (servo ON)	0	1	0
Execution of Return to Origin	0	1	1
Position maintained after completion of the Return to Origin operation	0	1	0
Execution of Step Data	#	1	1
Maintain current position after Step Data execution	#	1	0
Card Motor power OFF	0	0	0

#: Operation Step Data No. (1-15, 20)

 **Caution**

Execute the following Step Data only after the Card Motor has completed the current operation.
Otherwise the Card Motor may malfunction unexpectedly.

(7) Alarm History Command "RE"Details

This command reads the alarm history saved in the controller. The alarm history can be cleared by setting the parameter to "0" (sets the whole alarm history to no.0)

This command can be used to check alarm details when they occur.

(i) Required Format

(a) Data read

Start Code	ID	Space	Command	Check Sum	End Code
:	"01"- "FF"	20h	"RE"	LRC	CR, LF

(b) Data clearance

Start Code	ID	Space	Command	Space	Clear	Check Sum	End Code
:	"01"- "FF"	20h	"RE"	20h	"0"	LRC	CR, LF

(ii) Response Format

(a) Data read

Start Code	ID	Command	Result	History 1 Alarm No.	History 2 Alarm No.	...	History 20 Alarm No.	Check Sum	End Code
:	"01"- "FF"	"RE"	"OK"	See the table below	See the table below	...	See the table below	LRC	CR, LF

(b) Data clearance

Start Code	ID	Command	Result	Check Sum	End Code
:	"01"- "FF"	"RE"	"OK"	LRC	CR, LF

* Response Format (Ver2.10 or earlier)

The number of alarm history of version 2.1 and before is up to 4.

(a) Data readout

Start code	ID	Command	Result	History 1 Alarm No.	History 2 Alarm No.	History 3 Alarm No.	History 4 Alarm No.	Check sum	End code
:	"01"- "FF"	"RE"	"OK"	See the table below	See the table below	See the table below	See the table below	LRC	CR,LF

(b) When clearing the data

Start code	ID	Command	Result	Checksum	End code
:	"01"- "FF"	"RE"	"OK"	LRC	CR,LF

(iii) Alarm No. and Name

Alarm No.	Hexadecimal value	Alarm name	Details
0	00h	No alarm	-
1	01h	Memory error	-
2	02h	Actuator cable disconnected	-
3	03h	Temperature error	-
4	04h	Over current error	Motor overload error
5	05h		I/O signalover current error
6	06h	Parameter error	Originparametererror
7	07h		Step Data parameter error
8	08h		Invalid parametererror
9	09h		Pulse speed error
10	0Ah	Pulse input error	Pulse overflow error
11	0Bh	Return to Origin position non-execution error	-

* Store the alarm number which is generated when the alarm occurred in History 1, and the existing entry will be moved to entry 2, the existing entry 2 moved to entry 3, and so on.

For details and solutions to alarms, see [Section 16, Alarm Detection](#) in the "Card Motor Controller (Step Data input edition)" operation manual.



Caution

Ensure the alarm history is cleared only after taking corrective action in response to the alarms.

When the alarm history is cleared, any currently occurring alarms will also be cleared.

5.5 Error Code

The data responses received from each command is converted to binary (1byte) → ASCII (2bytes).

Problems Code	Name	Description · Countermeasures
01h	ILLEGAL FUNCTION	<p>< Description > An undefined command has been specified.</p> <p>< Countermeasures > Return the command listed in 5.3 Command List.</p>
03h	ILLEGAL DATA VALUE	<p>< Description > Content of the sent data is incorrect. (1) The format of the transmitted data does not match the request format of each command. (2) The argument value of the transmitted data is out of range.</p> <p>< Countermeasures > Refer to 5.4 Command Details and send the value of the argument within the set range and in the correct frame format.</p>
06h	SLAVE DEVICE BUSY	<p>< Description > The request cannot be processed due to a controller busy status. (1) The following command was sent during a reply after receiving the communication. (2) EE command is sent while saving data to memory</p> <p>< Countermeasures > (1) After the controller has successfully replied, send the following command. (2) Perform a transmission retry on the upper level device.</p>
11h	CHECKSUM ERROR	<p>< Description > The sent checksum does not match the checksum calculated inside the controller.</p> <p>< Countermeasures > Send the correct checksum value referring to 8.1 Checksum Calculation Procedure 8.2 Checksum Calculation Examples.</p>
12h	NOT ADU	<p>< Description > Data does not exist.</p> <p>< Countermeasures > Refer to 5.4 Command Details and send the data in the correct frame format.</p>

Note) If a communication error (frame error, overrun error, parity error etc.) occurs, received data will be discarded, as a response cannot be made.

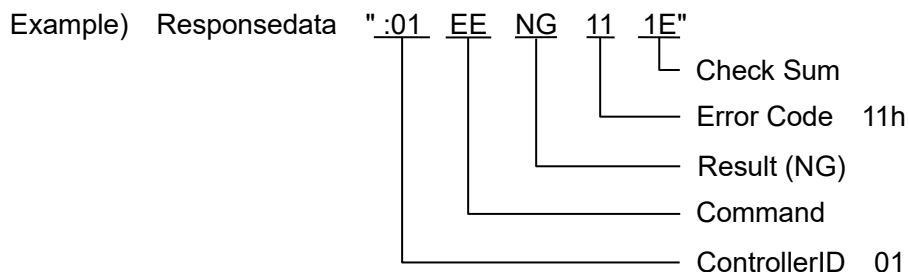

6. Card Motor Controller Operation Examples

6.1 Basic Settings, I/O Configuration

Set the following criteria in the controller using the controller configuration software.

(See the "Card Motor Controller (Step Data input edition)" operation manual for details)

- Input type (select Step Data input type)
- Card Motor Mounting Orientation
- Return to Origin Method
- Step Data Input Method
- Output signal functions
- Area Range
- Threshold Force Value

6.2 Step Data Configuration

See below for the Step Data configuration procedure.

- (1) Cut the Power from the Card Motor using the "OE" command during Step Data operation.
The power supply to the Card Motor does not need to be cut when configuring Step Data no. 20 in direct operation.
- (2) Step Data configuration is performed using the "EE" command.
- (3) Configured data is saved into the memory using the "EU" command. (Not required in direct operation)
- (4) Control data is reflected into the memory using the "AB" command. (Not required in direct operation)

* Points of caution while configuring Step Data

- (1) If a communication error (framing error, overrun error, parity error etc.) occurs, a response cannot be made, resulting in received data being discarded and no irregular response with error code sent. Therefore prepare retry/time-out processing in the transmission device.
- (2) Use the controller configuration software to pre-set the basic controller settings.
- (3) The Step Data overwrite target frequency for Step Data numbers 1-15 is 4,000,000. Please avoid excessive overwriting.
- (4) Do not cut the power while data is being saved.
It is recommended that the controller be initialised using the controller configuration software in the case that the power is cut accidentally.
- (5) Always ensure that Step Data configuration is made while the power supply to the Card Motor is off in Step Data operation (ENABLE byte set to "0" in the OE command). If Step Data configuration is done while the Card Motor is powered on, malfunction may occur.
- (6) Ensure that the Return to Origin operation is completed before operation after any Step Data changes for Step Data operation.

Caution

Execute the EU and AB command when the SVON signal is OFF in parallel I/O operation or when the ENABLE of the OE command is 0 in serial I/O operation.

Otherwise the Card Motor may malfunction unexpectedly.

6.3 Operation Data Acquisition

This explains the Card Motor operation data acquisition procedure.

(1) Operation data is acquired using the "MO" command.

6.4 Operation Instruction Method

This explains the procedure for operation instructions to the Card Motor using serial communication.

(1) Ensure the SVON signal input to the controller is turned OFF and the Card Motor power cut.

(2) Switch the controller to serial I/O operation using the "MD" command.

(3) Specify Step Data to executed and operation instructions using the "OE" command according to each operation method as indicated below.

In Step Data Operation: Step Data 1-15 will be defined.

In Direct Operation : Step Data 20 will be defined.

Caution

When driving with the OE command, be sure to send ACTION "0" before driving, and then send ACTION."1".

When the ACTION is changed from "0" to "1", the operation of the Step Data selected in STEP will start.

6.5 Program Examples

Program examples for how to perform Basic settings and Step Data setting by serial communication are listed below. In the following examples, the response data is indicated in ASCII notation; space is indicated as “_” and command monitor contents is indicated as “***”. The checksum and end code are omitted.

(1) Basic Settings

Use the dedicated “LATC Configurator” controller configuration software.

Please download this controller configuration software from the SMC website.

https://www.smcworld.com/products/pickup/en-jp/electric_actuator/download.html

(2) Communication check

Send an MO command to check if a successful response is returned.

	ASCII notation	Hexadecimal notation
Requested data	: 01_MOE3[CR,LF]	3Ah 30h 31h 20h 4Dh 4Fh 45h 33h 0Dh 0Ah
Response data (normal response)	: 01MOOK**	

For correspondence between ASCII notation and hexadecimal notation, refer to the [8.4 ASCII Code List](#). In ASCII notation, “_” indicates space (20h) and “CR, LF” indicates the end code.

“***” for the response data indicates the controller status.

(3) Step Data Configuration Examples

Instructions issued to set Step Data No. 1 in the Card Motor controller (controller ID1) to movement time: 0.1 sec and target position: 10 mm.

The "EU" and "AB" commands are not required in direct operation (Step Data No. 20).

No	Data Requested	Data Responded	Operation Details
1	:01_EE_3_1_1_0.1	:01EEOK	Step Data No. 1 PositioningTime set to 0.1sec.
2	:01_EE_3_0_10000	:01EEOK	Step Data No. 1 Target Position set to 10mm.
3	:01_EU	:01EUOK	Instruction to save altered Step Data sent.
4	:01_AB	:01ABOK	Instruction to reflect altered Step Data sent.

Caution

Do not specify values other than between 3, 17 and 22 for INDEX1, and between 0 and 14 for INDEX2.

Alarms or Card Motor malfunction may occur unexpectedly.

(4) Return to Origin

Change the Card Motor controller (controller ID1) operation mode to serial I/O operation, and send Return to Origin instructions.

No	Data Requested	Data Responded	Operation Details
1	:01_OE_0_0_0	:01OEOK	Instruction to turn Card Motor power OFF sent.
2	:01_MD_1	:01MDOK	Instruction to change the Card Motor controller operation mode to "serial I/O operation" sent.
3	:01_OE_0_1_0	:01OEOK	Instruction to turn Card Motor power ON sent.
4	:01_OE_0_1_1	:01OEOK	Instruction to perform the Return to Origin operation sent.
5	:01_MO	:01MOOK**	Monitor command to acquire INP signal information sent.
6	Repeat No. 5-6		Repeat until the INP changes to "1" for the I/O data received. Return to Origin is complete once the INP becomes "1".
7	:01_OE_0_1_0	:01OEOK	Transit to position retention and ends the return to origin operation.

(5) Positioning Operation (Step Data Operation) Example

Change the Card Motor controller (controller ID1) operation mode to serial I/O operation, perform Return to Origin and repeat Step Data No.1 and 2.

* If returning to origin has already been completed, omit No.1 to No.6 and start from No7.

No	Data Requested	Data Responded	Operation Details
1	:01_OE_0_0_0	:01OEOK	Instruction to turn Card Motor power OFF sent.
2	:01_MD_1	:01MDOK	Instruction to change the Card Motor controller operation mode to "serial I/O operation" sent.
3	:01_OE_0_1_0	:01OEOK	Instruction to turn Card Motor power ON sent.
4	:01_OE_0_1_1	:01OEOK	Instruction to perform the Return to Origin operation sent.
5	:01_MO	:01MOOK**	Monitor command to acquire INP signal information sent.
6	Repeat No. 5-6		Repeat until the INP changes to "1" for the I/O data received. (Return to Origin is complete once the INP becomes "1".)
7	:01_OE_1_1_0	:01OEOK	Instruction to hold current position sent. (Preparation for start of Step Data No. 1 operation)
8	:01_OE_1_1_1	:01OEOK	Instruction to execute Step Data no.1 sent.
9	:01_MO	:01MOOK**	Sends a monitor command to acquire the INP signal information.
10	Repeat No. 9-10		Acquires the information repeatedly until the received information shows that the INP is "1". (INP = 1 indicates that the target location has been reached.)
11	-		After settling time, the operation of step data No.1 is completed.
12	:01_OE_2_1_0	:01OEOK	Instruction to hold current position sent. (Preparation for start of Step Data No. 2 operation)
13	:01_OE_2_1_1	:01OEOK	Instruction to execute Step Data no.2 sent.
14	:01_MO	:01MOOK**	Sends a monitor command to acquire the INP signal information.
15	Repeat No. 14-15		Acquires the information repeatedly until the received information shows that the INP is "1". (INP = 1 indicates that the target location has been reached.)
16	-		After settling time, the operation of step data No.2 is completed.
17	Repeat No. 7-17		Step Data No. 1-2 will be repeated.

(6) Positioning Operation (Direct Operation) Example

Change the pre-configured Card Motor controller (controller ID1, Cycle Time Input Method) operation mode to serial I/O operation, perform Return to Origin and direct operation instructions are used to move the table from 5 mm to 10 mm.

* If returning to origin has already been completed, omit No.1 to No.6 and start from No7.

No	Data Requested	Data Responded	Operation Details
1	:01_OE_0_0_0	:01OEOK	Instruction to turn Card Motor power OFF sent.
2	:01_MD_1	:01MDOK	Instruction to change the Card Motor controller operation mode to "serial I/O operation" sent.
3	:01_OE_0_1_0	:01OEOK	Instruction to turn Card Motor power ON sent.
4	:01_OE_0_1_1	:01OEOK	Instruction to perform the Return to Origin operation sent.
5	:01_MO	:01MOOK**	Monitor command to acquire INP signal information sent.
6	Repeat No. 5-6		Repeat until the INP changes to "1" for the I/O data received. Return to Origin is complete once the INP becomes "1".
7	:01_EE_22_0_5000	:01EEOK	Direct operation Step Data parameter no. 20 is configured for: Target position 5 mm, positioning time 0.1 s.
8	:01_EE_22_1_0.1	:01EEOK	
9	:01_OE_20_1_0	:01OEOK	Instruction to hold current position sent. (Preparation for start of Step Data No. 20 operation)
10	:01_OE_20_1_1	:01OEOK	Instructions to execute step-data no.20 sent.
11	: 01_MO	: 01MOOK**	Sends a monitor command to acquire the INP signal information.
12	Repeat No. 11-12		Acquires the information repeatedly until the received information shows that the INP is "1". (INP = 1 indicates that the target location has been reached.)
13	-		After settling time, the operation of step data No.20 is completed.
14	:01_EE_22_0_10000	:01EEOK	Step Data No. 20 target position changed to 10mm.
15	:01_OE_20_1_0	:01OEOK	Instruction to hold current position sent. (Preparation for start of Step Data No. 20 operation)
16	:01_OE_20_1_1	:01OEOK	Instruction to execute Step Data no.20 sent.
17	:01_MO	:01MOOK**	Sends a monitor command to acquire the INP signal information.
18	Repeat No. 17-18		Acquires the information repeatedly until the received information shows that the INP is "1". (INP = 1 indicates that the target location has been reached.)
19	-		After settling time, the operation of step data No.20 is completed.

Caution

The step data (e.g. target value) currently in operation will not be changed by simply changing Step Data No. 20 using only the EE command.

After sending ACTION,"0" ("OE_20_1_0") with the OE command, and then sending action,"1" ("OE_20_1_1"), the step data is changed and the operation begins.

Configure the contents of Step Data No.20 before using Direct Operation.

The content is reset when it is turned off.

(7) Operation Data Acquisition Example

E.g) Card Motor and controller operation data is acquired from the Card Motor controller (controller ID1, CycleTimeEntryMethod).

No	Data Requested	Data Responded	Operation Details
1	:01_MO	:01MOOK**	Monitor command to acquire Card Motor operation information sent.
2	Operation Data Judgement		The Card Motor operation state will be determined from the operation data acquired.

(8) Alarm History Acquisition Example

E.g) The alarm history saved in the Card Motor controller (controller ID1) is acquired.

No	Data Requested	Data Responded	Operation Details
1	:01_RE	:01REOK**	Alarm history command to acquire alarm history sent.
2	Operation Data Judgement		Judgement on acquired alarm history.

(9) Alarm History Clearance Example

E.g) The alarm history saved in the Card Motor controller (controller ID1) is cleared.

No	Data Requested	Data Responded	Operation Details
1	:01_RE_0	:01REOK	Alarm history command to clear alarm history sent.

Caution

Alarm Reset

When an alarm occurs, reset the alarm using the SVON reset function (turn the SVON signal ON and back OFF again) after taking corrective measures.

Ensure the alarm history is cleared only after taking corrective action in response to the alarms.

When the alarm history is cleared, any currently occurring alarms will also be cleared.

7. Option (Separately Sold Products)

7.1 Communication cable

The cable used to connect one controller to an upper level device (PLC).

(1) Communication cable

i. How to Order

LATH 6 - 1

● Cable length

1	1m
---	----

ii. Dimensions

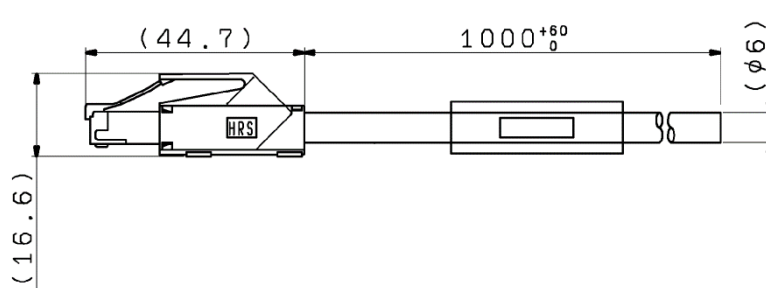

iii. Wiring diagram

Terminal No.	Insulation color	Function
1	—	NC
2	—	NC
3	White	SD+
4	Black	SD-
5	—	NC
6	—	NC
7	—	NC
8	—	NC
Connector case	Shield	FG

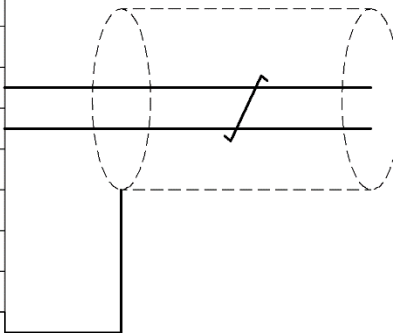

7.2 Branch communication cable

The cable used to connect multiple controllers to an upper level device (PLC).

(1) Branch communication cable (between an upper level device and a branch connector)

i. How to order

LATH7-1

● Cable length

1	1m
----------	----

ii. Dimensions

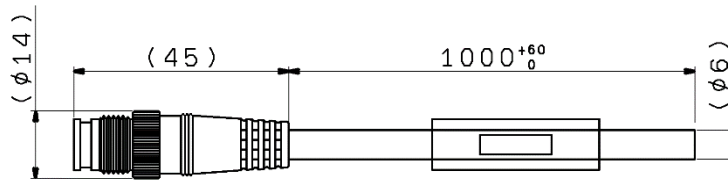

iii. Wiring diagram

Terminal	No.Insulation color	Function
1	—	NC
2	White	SD+
3	Shield	FG
4	Black	SD-

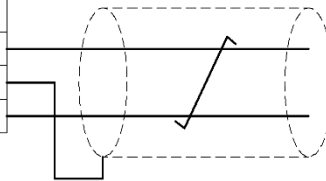

(2) Communication cable (between the branch connector and controller)

i. How to order

LEC-CG1-L

● Cable length

K	0.3m
L	0.5m
1	1m

ii. Dimensions

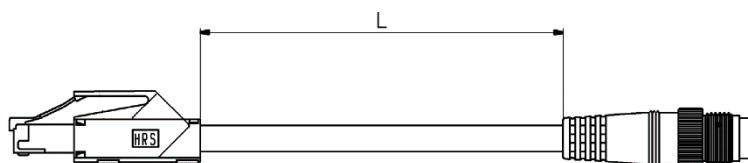

(3) Cable between branches (between the branch connectors)

i. How to order

LEC - CG2 - L

● Cable length

K	0.3m
L	0.5m
1	1m

ii. Dimensions

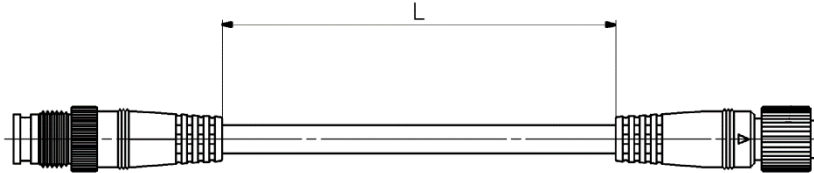

(4) Branch connector

i. How to order

LEC - CGD

● Branch connector

ii. Dimensions

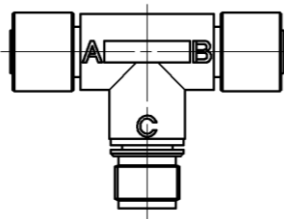

(5) Terminating resistor

i. How to order

LEC - CGR

ii. Dimensions

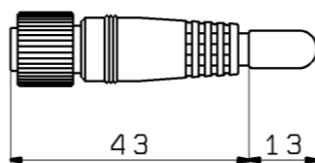

8. Reference Information

8. 1 Checksum Calculation Procedure

The checksum calculation is based on the LRC method.

- (1) All sent data is added, excluding the Start/End codes.
- (2) Subtract FFh from the last 2 bytes of the calculation result in step (1).
- (3) Add 1h to the calculation result in step (2).

8. 2. Checksum Calculation Examples

E.g) When sending the controller monitor command to a controller with ID1.

Transmission data to be used in the checksum calculation ... "0" , "1" , "space" ,"M" ,"O"

- (1) $30h + 31h + 20h + 4Dh + 4Fh = 11Dh$
- (2) $FFh - 1Dh = E2h$
- (3) $E2h + 1h = E3h$... Checksum = "E3" (= 45h,33h)

8. 3 Communication Response Time Guides

Guides for the communication response time are calculated below for each command request.

Command	Communication response time [ms] (guideline)		
	2400bps	19200bps	57600bps
EE	145	25	10
EU	105	20	10
AB	105	20	10
MO	245	35	15
MD	115	20	10
OE	130	20	10

* The communication response time does not include the processing time of the upper level device. When calculating the time taken for communication, take into account the processing time of the upper level equipment.

Calculation Example)

Number of controllers connected: 5

Required transmission commands: EE,EU, AB

Communication response time (25 + 20 + 20) x 5 = 325 ms

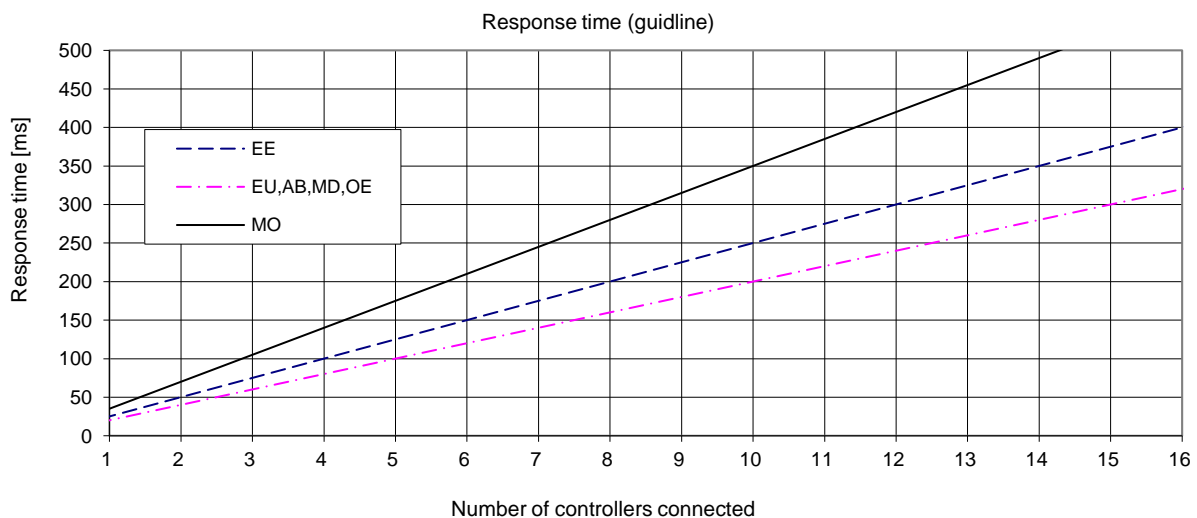

8. 4 ASCII Code List

Decimal	Hexadecimal	ASCII	Decimal	Hexadecimal	ASCII	Decimal	Hexadecimal	ASCII	Decimal	Hexadecimal	ASCII
0	0	NUL	32	20	SP	64	40	@	96	60	`
1	1	SOH	33	21	!	65	41	A	97	61	a
2	2	STX	34	22	"	66	42	B	98	62	b
3	3	ETX	35	23	#	67	43	C	99	63	c
4	4	EOT	36	24	\$	68	44	D	100	64	d
5	5	ENQ	37	25	%	69	45	E	101	65	e
6	6	ACK	38	26	&	70	46	F	102	66	f
7	7	BEL	39	27	'	71	47	G	103	67	g
8	8	BS	40	28	(72	48	H	104	68	h
9	9	HT	41	29)	73	49	I	105	69	i
10	0A	LF	42	2A	*	74	4A	J	106	6A	j
11	0B	VT	43	2B	+	75	4B	K	107	6B	k
12	0C	FF	44	2C	,	76	4C	L	108	6C	l
13	0D	CR	45	2D	-	77	4D	M	109	6D	m
14	0E	SO	46	2E	.	78	4E	N	110	6E	n
15	0F	SI	47	2F	/	79	4F	O	111	6F	o
16	10	DLE	48	30	0	80	50	P	112	70	p
17	11	DC1	49	31	1	81	51	Q	113	71	q
18	12	DC2	50	32	2	82	52	R	114	72	r
19	13	DC3	51	33	3	83	53	S	115	73	s
20	14	DC4	52	34	4	84	54	T	116	74	t
21	15	NAK	53	35	5	85	55	U	117	75	u
22	16	SYN	54	36	6	86	56	V	118	76	v
23	17	ETB	55	37	7	87	57	W	119	77	w
24	18	CAN	56	38	8	88	58	X	120	78	x
25	19	EM	57	39	9	89	59	Y	121	79	y
26	1A	SUB	58	3A	:	90	5A	Z	122	7A	z
27	1B	ESC	59	3B	;	91	5B	[123	7B	{
28	1C	FS	60	3C	<	92	5C	¥	124	7C	
29	1D	GS	61	3D	=	93	5D]	125	7D	}
30	1E	RS	62	3E	>	94	5E	^	126	7E	~
31	1F	US	63	3F	?	95	5F	_	127	7F	DEL

Revision history

1ST printing: Revised in December 2014
A: Revised in July 2015
B: Revised in November 2015
C: Revised in June 2020

SMC Corporation

4-14-1, Sotokanda, Chiyoda-ku, Tokyo 101-0021 JAPAN

Tel: + 81 3 5207 8249 Fax: +81 3 5298 5362

URL <https://www.smcworld.com/>

NOTE: Specifications are subject to change without prior notice and any obligation on the part of the manufacturer.

© 2020 SMC Corporation All Rights Reserved

