

Membrane Air Dryer

25A-IDG Series

Single Unit/Standard Dew Point -40°C/-60°C Specifications



How to Order

25A - IDG **50** **L** **A -** **03** **-** **P**

Series compatible with secondary batteries

Size

30
50
60
75
100

Semi-standard

Symbol	Contents
Nil	None
R	Flow direction (Right → Left)

Fitting for purge air discharge

Symbol	Contents
P	With fitting for purge air discharge

Standard dew point temperature

Symbol	Standard dew point [°C]
L	-40
S	-60

Symbol	30	50	60	75	100
L	●	●	●	●	●
S	—	—	●	●	●

Accessory

Symbol	Description
Nil	None
B	With bracket

* When symbol B is indicated, a bracket assembly with a part number shown in the table left below is shipped together as an accessory, (but not assembled).

Port size

Symbol	Bore	Size				
		30	50	60	75	100
02	Rc1/4	●	●	—	—	—
03	Rc3/8	●	●	●	●	●
04	Rc1/2	—	—	●	●	●

Piping materials

Piping to the outlet side with piping made of water-absorbent or hydrophilic material (nylon, etc.) may result in a rising dew point on the outlet side. Therefore, be sure to use either stainless steel or fluoropolymer piping and fittings.

Bracket Assembly (Accessory) Part Nos.

Part no.	Applicable model
25A-BM64	25A-IDG30LA, 50LA
25A-BM65	25A-IDG60LA, 75LA, 100LA

* Assembly of a bracket and 2 mounting screws

* The 25A- series specifications are the same as those of the standard model.

[Click here for details.](#)

Dimensions

25A-IDG30LA
25A-IDG50LA

Purge air for dew point indicator

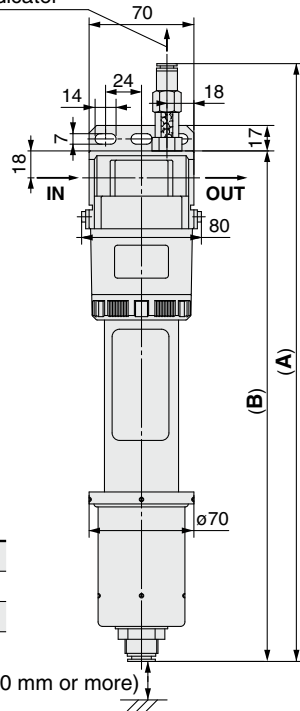

Model	A	B
25A-IDG30LA	361	302
25A-IDG50LA	400	341

(Maintenance space 100 mm or more)

Purge air discharge tubing port for dew point indicator
Applicable tubing O.D.: $\phi 8$

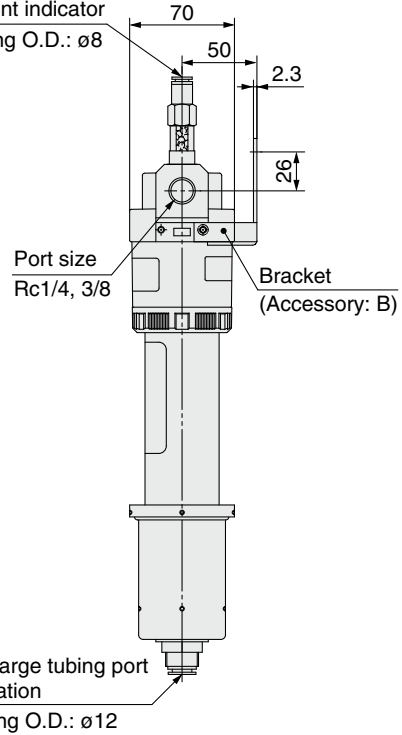

Purge air discharge tubing port for dehumidification
Applicable tubing O.D.: $\phi 12$

25A-IDG60LA
25A-IDG75LA
25A-IDG100LA

Purge air for dew point indicator

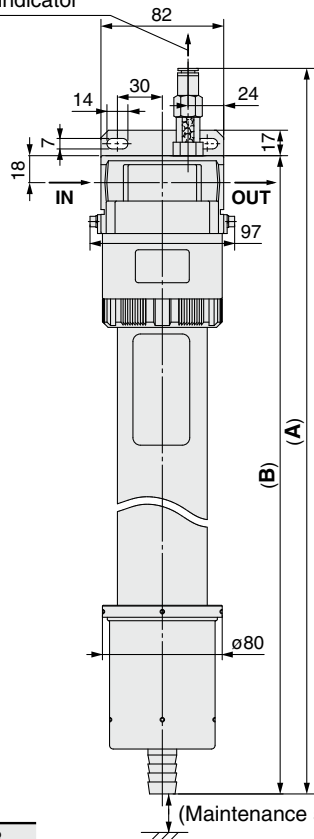

Model	A	B
25A-IDG60LA	426	367
25A-IDG75LA	495	436
25A-IDG100LA	560	501

(Maintenance space 100 mm or more)

Purge air discharge tubing port for dew point indicator
Applicable tubing O.D.: $\phi 8$

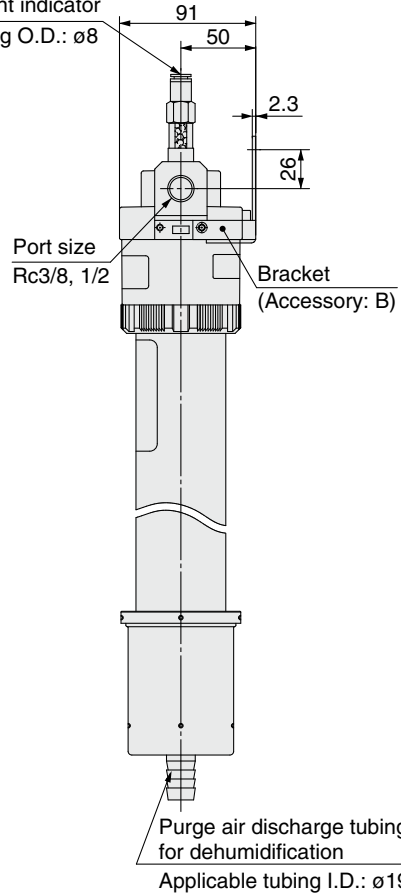

Purge air discharge tubing port for dehumidification
Applicable tubing I.D.: $\phi 19$

Directional Control Valves
Air Cylinders
Related Products
Rotary Actuators
Air Grippers
Vacuum Equipment
Air Preparation Equipment
Clean Air Filters
Modular F.R.L./Pressure Control Equipment
Fittings/Flow Control Equipment
Detection Switches
Fluid Control Equipment
Electric Actuators
Auto Switches

Main Line Filter

25A-AFF Series



How to Order

25A-AFF2C to 25A-AFF22C

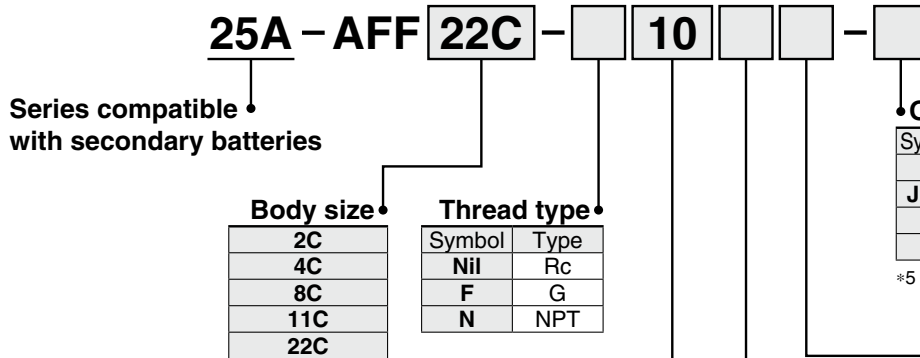

Bracket Assembly Part Nos.*3

Applicable model	Part no.
25A-AFF2C	25A-AM-BM101
25A-AFF4C	25A-AM-BM102
25A-AFF8C	25A-AM-BM103
25A-AFF11C	25A-AM-BM104
25A-AFF22C	25A-AM-BM105

*3 Assembly of a bracket and 2 mounting screws

Port size

Symbol	Size	Applicable body size				
		2C	4C	8C	11C	22C
01	1/8	●	—	—	—	—
02	1/4	●	●	—	—	—
03	3/8	—	●	●	—	—
04	1/2	—	—	●	●	—
06	3/4	—	—	—	●	●
10	1	—	—	—	—	●

Auto drain*4

Symbol	Description
Nil	Drain cock (Without auto drain)
C	N.C. auto drain
D	N.O. auto drain

*4 Only one drain exhaust method can be selected. The drain cock, N.C. auto drain, N.O. auto drain and drain guide cannot be selected together.

Accessory

Symbol	Description
Nil	—
B	Bracket *2

*2 When symbol "B" is indicated, a bracket assembly with a part number shown in the left table is shipped together as an accessory, (but not assembled).

25A-AFF37B/75B

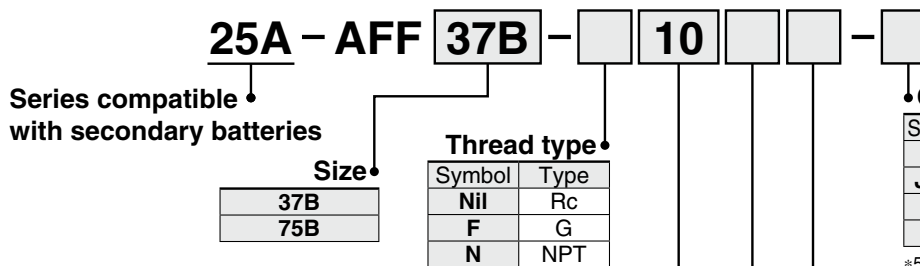

Symbol	Size	Applicable body size	
		37B	75B
10	1	●	—
14	1 1/2	●	●
20	2	—	●

Bracket Assembly Part Nos.*3

Applicable model	Part no.
25A-AFF37B	25A-BM56
25A-AFF75B	25A-BM57

*3 Assembly of a bracket and 2 mounting screws

Accessory

Symbol	Description
Nil	—
B	Bracket *1

*1 When symbol "B" is indicated, a bracket assembly with a part number shown in the left table is shipped together as an accessory, (but not assembled).

Auto drain*4

Symbol	Description
Nil	Drain cock (Without auto drain) *2
D	N.O. auto drain (37B only)

*2 Body size 75B is equipped with a ball valve (Rc 3/8 female threaded).

*4 Body size 37B: Only one drain exhaust method can be selected. The drain cock, N.O. auto drain and drain guide cannot be selected together.

* The 25A- series specifications and dimensions are the same as those of the standard model.

[Click here for details.](#)

Mist Separator

25A-AM Series



How to Order

25A-AM150C to 25A-AM550C

25A - AM 550C - [] 10 [] [] - []

Series compatible with secondary batteries

Body size

150C
250C
350C
450C
550C

Thread type

Symbol	Type
Nil	Rc
F	G
N	NPT

Option

Symbol	Description
Nil	—
J*4,*5	Drain guide 1/4 female threaded
R	IN-OUT reversal direction
T	With element service indicator

*5 Drain piping and piping for a stop valve such as ball valve are required.

Auto drain*4

Symbol	Description
Nil	Drain cock (Without auto drain)
C	N.C. auto drain
D	N.O. auto drain

*4 Only one drain exhaust method can be selected. The drain cock, N.C. auto drain, N.O. auto drain and drain guide cannot be selected together.

Accessory

Symbol	Description
Nil	—
B	Bracket *2

*2 When symbol "B" is indicated, a bracket assembly with a part number shown in the left table is shipped together as an accessory, (but not assembled).

Port size

Symbol	Size	Applicable body size				
		150C	250C	350C	450C	550C
01	1/8	●	—	—	—	—
02	1/4	●	—	—	—	—
03	3/8	—	●	—	—	—
04	1/2	—	—	●	●	—
06	3/4	—	—	—	●	●
10	1	—	—	—	—	●

Bracket Assembly Part Nos.*3

Applicable model	Part no.
25A-AM150C	25A-AM-BM101
25A-AM250C	25A-AM-BM102
25A-AM350C	25A-AM-BM103
25A-AM450C	25A-AM-BM104
25A-AM550C	25A-AM-BM105

*3 Assembly of a bracket and 2 mounting screws

25A-AM650/850

25A - AM 650 - [] 10 [] [] - []

Series compatible with secondary batteries

Body size

650
850

Thread type

Symbol	Type
Nil	Rc
F	G
N	NPT

Option

Symbol	Description
Nil	—
J*4,*5	Drain guide 1/4 female threaded (650 only)
R	IN-OUT reversal direction
T	With element service indicator

*5 Drain piping and piping for a stop valve such as ball valve are required.

Auto drain*4

Symbol	Description
Nil	Drain cock (Without auto drain) *2
D	N.O. auto drain (650 only)

*2 Body size 850 is equipped with a ball valve (Rc 3/8 female threaded).

*4 Body size 650: Only one drain exhaust method can be selected. The drain cock, N.O. auto drain and drain guide cannot be selected together.

Accessory

Symbol	Description
Nil	—
B	Bracket *1

*1 When symbol "B" is indicated, a bracket assembly with a part number shown in the left table is shipped together as an accessory, (but not assembled).

Port size

Symbol	Size	Applicable body size	
		650	850
10	1	●	—
14	1 1/2	●	●
20	2	—	●

Bracket Assembly Part Nos.*3

Applicable model	Part no.
25A-AM650	25A-BM56
25A-AM850	25A-BM57

*3 Assembly of a bracket and 2 mounting screws

* The 25A- series specifications and dimensions are the same as those of the standard model.

[Click here for details.](#)



Directional Control Valves

Air Cylinders

Related Products

Rotary Actuators

Air Grippers

Vacuum Equipment

Air Preparation Equipment

Clean Air Filters

Modular F.R.L./Pressure Control Equipment

Fittings/Flow Control Equipment

Detection Switches

Fluid Control Equipment

Electric Actuators

Auto Switches

Micro Mist Separator

25A-AMD Series



How to Order

25A-AMD150C to 25A-AMD550C

25A - AMD 550C - [] [10] [] [] - []

Series compatible with secondary batteries

Body size

150C
250C
350C
450C
550C

Thread type

Symbol	Type
Nil	Rc
F	G
N	NPT

Option

Symbol	Description
Nil	—
J*4,*5	Drain guide 1/4 female threaded
R	IN-OUT reversal direction
T	With element service indicator

*5 Drain piping and piping for a stop valve such as ball valve are required.

Auto drain*4

Symbol	Description
Nil	Drain cock (Without auto drain)
C	N.C. auto drain
D	N.O. auto drain

*4 Only one drain exhaust method can be selected. The drain cock, N.C. auto drain, N.O. auto drain and drain guide cannot be selected together.

Accessory

Symbol	Description
Nil	—
B	Bracket *2

*2 When symbol "B" is indicated, a bracket assembly with a part number shown in the left table is shipped together as an accessory, (but not assembled).

Bracket Assembly Part Nos.*3

Applicable model	Part no.
25A-AMD150C	25A-AM-BM101
25A-AMD250C	25A-AM-BM102
25A-AMD350C	25A-AM-BM103
25A-AMD450C	25A-AM-BM104
25A-AMD550C	25A-AM-BM105

*3 Assembly of a bracket and 2 mounting screws

Port size

Symbol	Size	Applicable body size				
		150C	250C	350C	450C	550C
01	1/8	●	—	—	—	—
02	1/4	●	●	—	—	—
03	3/8	—	●	●	—	—
04	1/2	—	—	●	●	—
06	3/4	—	—	—	●	●
10	1	—	—	—	—	●

25A-AMD650/850

25A - AMD 650 - [] [10] [] [] - []

Series compatible with secondary batteries

Body size

650
850

Thread type

Symbol	Type
Nil	Rc
F	G
N	NPT

Option

Symbol	Description
Nil	—
J*4,*5	Drain guide 1/4 female threaded (650 only)
R	IN-OUT reversal direction
T	With element service indicator

*5 Drain piping and piping for a stop valve such as ball valve are required.

Auto drain*4

Symbol	Description
Nil	Drain cock (Without auto drain) *2
D	N.O. auto drain (650 only)

*2 Body size 850 is equipped with a ball valve (Rc 3/8 female threaded).

*4 Body size 650: Only one drain exhaust method can be selected. The drain cock, N.O. auto drain and drain guide cannot be selected together.

Accessory

Symbol	Description
Nil	—
B	Bracket *1

*1 When symbol "B" is indicated, a bracket assembly with a part number shown in the left table is shipped together as an accessory, (but not assembled).

Bracket Assembly Part Nos.*3

Applicable model	Part no.
25A-AMD650	25A-BM56
25A-AMD850	25A-BM57

*3 Assembly of a bracket and 2 mounting screws

Port size

Symbol	Size	Applicable body size	
		650	850
10	1	●	—
14	1 1/2	●	●
20	2	—	●

* The 25A- series specifications and dimensions are the same as those of the standard model. [Click here for details.](#)

Micro Mist Separator with Pre-filter 25A-AMH Series

RoHS



How to Order

25A-AMH150C to 25A-AMH550C

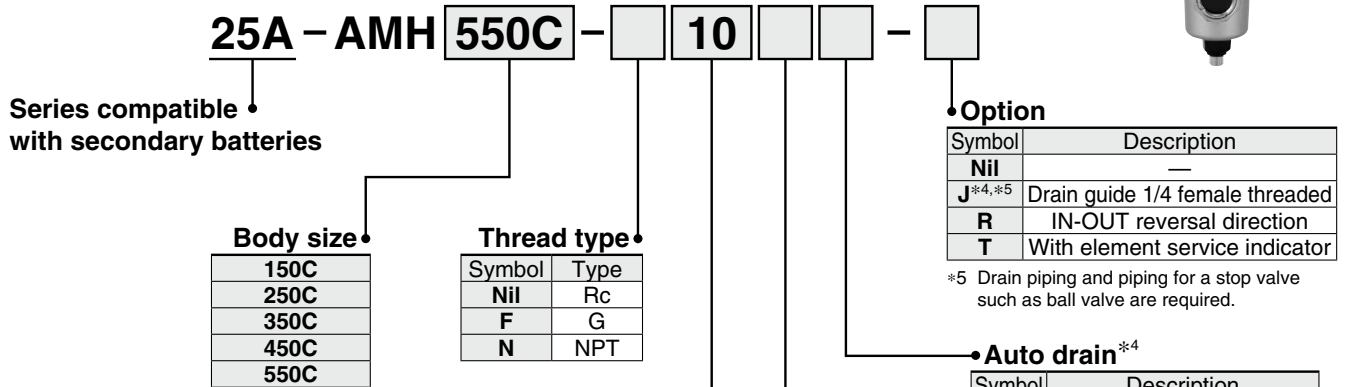

Bracket Assembly Part Nos.*3

Applicable model	Part no.
25A-AMH150C	25A-AMBM101
25A-AMH250C	25A-AMBM102
25A-AMH350C	25A-AMBM103
25A-AMH450C	25A-AMBM104
25A-AMH550C	25A-AMBM105

*3 Assembly of a bracket and 2 mounting screws

25A-AMH650/850

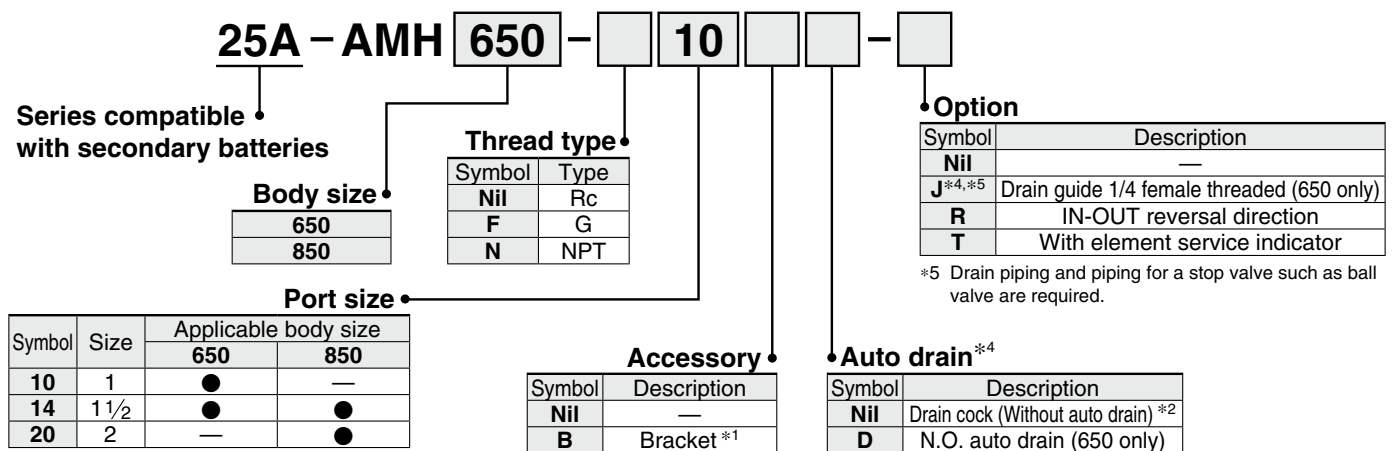

Bracket Assembly Part Nos.*3

Applicable model	Part no.
25A-AMH650	25A-BM56
25A-AMH850	25A-BM57

*3 Assembly of a bracket and 2 mounting screws

* The 25A- series specifications and dimensions are the same as those of the standard model. [Click here for details.](#)