

Low Particle Generation 2-Color Display Digital Flow Switch



0.2 to 10 L/min PFM710-X300
 0.5 to 25 L/min PFM725-X300
 1 to 50 L/min PFM750-X300

2 to 100 L/min PFM711-X300

2 to 200 L/min PFMB7201-X300

Particle Generation Characteristics (Reference Data)

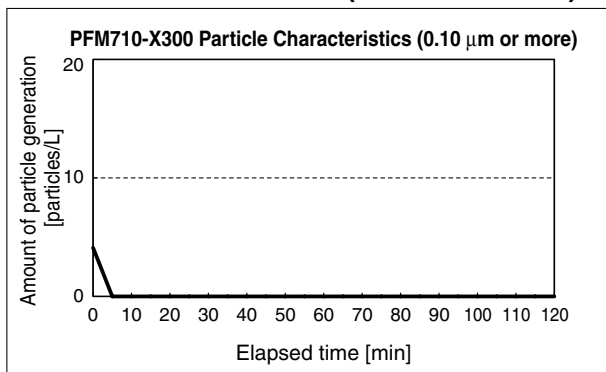

Metal Material of Parts in Contact with Fluid: Stainless Steel 304

<Application Example>

Flow control of a clean air blow in clean room environments

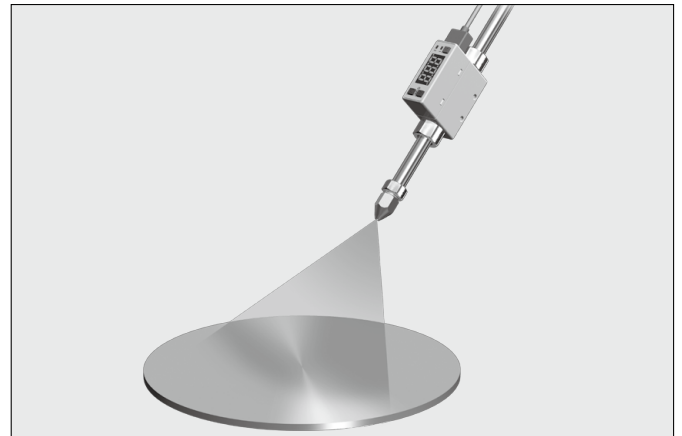

Specifications

Ultrasonic cleaning	Metal parts in contact with fluid: Fitting, Orifice, Mesh
Degreasing treatment	Body, O-ring
Air blow	Air blow of the fluid passage*1
Clean packaging	Antistatic bag (Double packaged)

*1 With Class 100 air in a Class 10000 clean room

* When the product is used for blowing, use caution to prevent the workpiece from being damaged by air entrained from the surrounding area.

Model	Applicable fluid	Detection method	Smallest settleable increment	Port size (Rc)	Rated flow range [L/min]									Reversible display mode	
					0.2	0.5	1	2	5	10	50	100	200		
PFM710-X300 	Dry air N ₂ Argon CO ₂	Thermal type (MEMS)	0.01 L/min	1/8	0.2 ————— 10									None	
					0.1 L/min	0.5 ————— 25									
						1 ————— 50									
						2 ————— 100									
PFMB7201-X300 	Dry air N ₂	Thermal type (MEMS) Bypass flow type	1 L/min	1/4	2 ————— 200										

PFM7/PFMB7-X300



PFM7/PFMB7-X300

Particle Generation Characteristics

Measuring Method

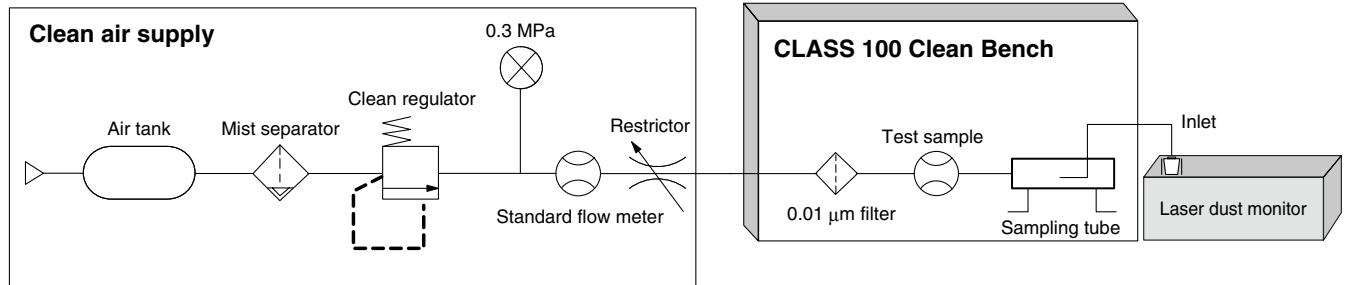

[Test Method]

Place a sampling tube at the latter stage of the test sample and measure the number of generated particles with a laser dust monitor.

[Measuring Conditions]

Measuring instrument	Description	Automatic particle counter using the light scattering method
		Minimum measurable particle diameter
	Suction flow rate	28 L/min
Setting conditions	Sampling time	1 min
	Interval time	4 min
	Sampling air flow	28 L

* The flow rate used during measuring is 100 L/min (30 L/min only for the PFM710).

Particle Generation Characteristics (Reference Data)

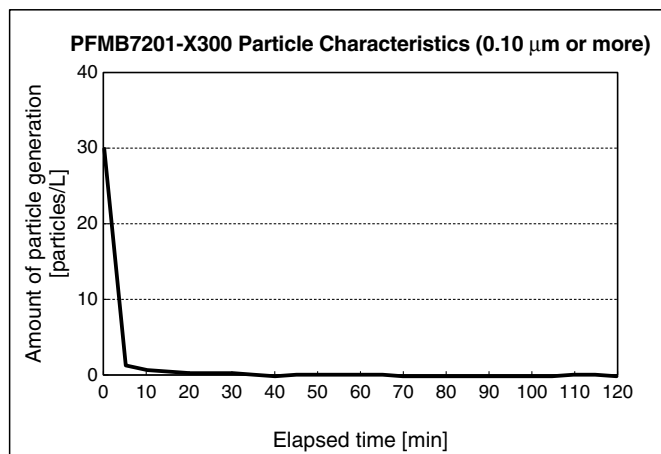
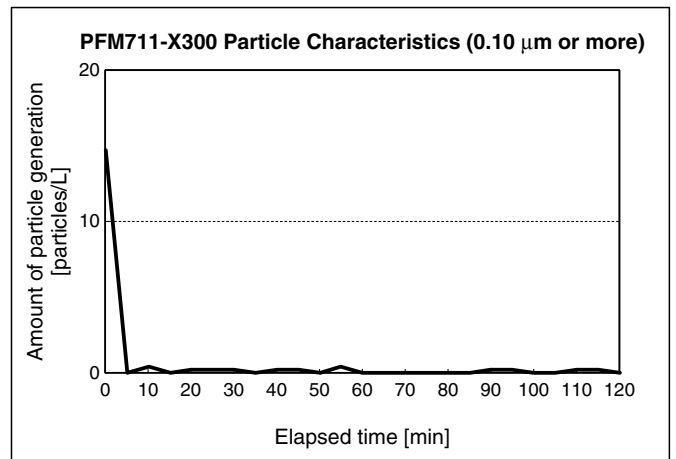
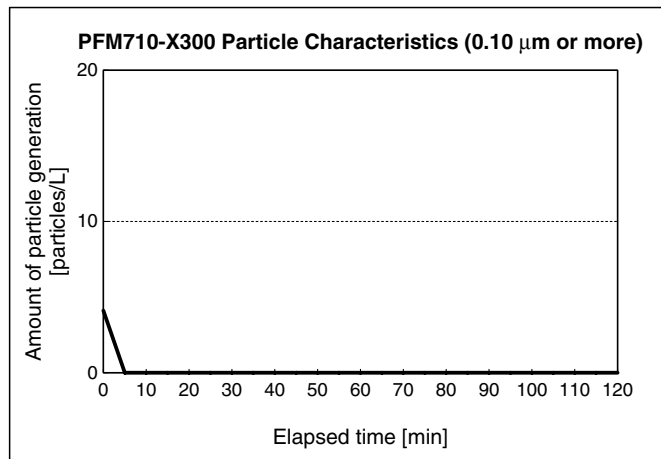



How to Order

Rated flow range:
0.2 to 100 L/min

PFM 7 10 - 01 - A - M - - - - X300

Rated flow range

10	0.2 to 10 (5) L/min
25	0.5 to 25 (12.5) L/min
50	1 to 50 (25) L/min
11	2 to 100 (50) L/min

* (): Fluid: CO₂

Port size

Symbol	Description	Flow range			
		10	25	50	11
01	Rc1/8	●	●	●	
02	Rc1/4				●

Output specification

	OUT1	OUT2
A	NPN	NPN
B	PNP	PNP
C	NPN	Analog 1 to 5 V
D	NPN	Analog 4 to 20 mA
E	PNP	Analog 1 to 5 V
F	PNP	Analog 4 to 20 mA
G	NPN	External input*1
H	PNP	External input*1

*1 User can select from accumulated value external reset, auto-shift, and auto-shift zero.

Unit specification

M	Fixed SI unit*1
Nil	With units selection function*2

*1 Fixed unit: Instantaneous flow: L/min
Accumulated flow: L

*2 This product is for overseas use only according to the New Measurement Act. (The SI unit type is provided for use in Japan.)

Operation manual

Nil	Yes (Japanese and English)
N	None

Calibration certificate

Nil	None
A	Yes

* The certificate is written in English and Japanese. Other languages are available as a special order.

Option 2

Nil	R
None	Bracket (For valve without flow adjustment) 10-ZS-33-M Tapping screw (Accessory)
T	
None	Panel mount adapter (For valve without flow adjustment) 10-ZS-33-J Panel mount adapter A Panel mount adapter B Panel Mounting bracket

* Options are shipped together with the product, but not assembled. When only optional parts are required, refer to Option 2/Part Nos.

Option 1

Nil	W
Lead wire with connector (2 m) Lead wire length 2 m	Lead wire with connector (2 m) + Rubber cover for connector (Silicone rubber) 10-ZS-33-F Lead wire length 2 m
Z	
Without lead wire with connector	* When only optional parts are required, refer to Option 1/Part Nos.

DIN Rail Mounting Bracket (Ordered Separately)

10-ZS-33-R

Stations

1	1 station
2	2 stations
3	3 stations
4	4 stations
5	5 stations

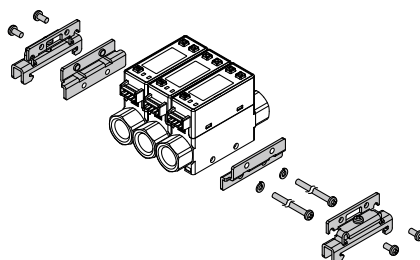

* The DIN rail should be provided by the customer.

Option 1/Part Nos.

Option	Part no.	Qty.	Note
Lead wire with connector	10-ZS-33-D	1	Lead wire: 2 m
Rubber cover (Silicone rubber)	10-ZS-33-F	1	For connector

Option 2/Part Nos.

Option	Part no.	Qty.	Note
Bracket	10-ZS-33-M	1	With 2 tapping screws (3 x 6)
Panel mount adapter	10-ZS-33-J	1	

PFM7-X300

Refer to the **Web Catalog** for flow switch precautions. For details on the specific product precautions, refer to the "Operation Manual" on the SMC website.

Specifications: PFM7-X300

Model		PFM710-X300	PFM725-X300	PFM750-X300	PFM711-X300
Applicable fluid		Dry air, N ₂ , Ar, CO ₂ (Air quality grade is JIS B 8392-1 1.1.2 to 1.6.2, ISO 8573-1 1.1.2 to 1.6.2)			
Rated flow range	Dry air, N ₂ , Ar	0.2 to 10 L/min	0.5 to 25 L/min	1 to 50 L/min	2 to 100 L/min
	CO ₂	0.2 to 5 L/min	0.5 to 12.5 L/min	1 to 25 L/min	2 to 50 L/min
Display range *1	Dry air, N ₂ , Ar	0.2 to 10.5 L/min	0.5 to 26.3 L/min	1 to 52.5 L/min	2 to 105 L/min
	CO ₂	0.2 to 5.2 L/min	0.5 to 13.1 L/min	1 to 26.2 L/min	2 to 52 L/min
Set point range *1	Dry air, N ₂ , Ar	0 to 10.5 L/min	0 to 26.3 L/min	0 to 52.5 L/min	0 to 105 L/min
	CO ₂	0 to 5.2 L/min	0 to 13.1 L/min	0 to 26.2 L/min	0 to 52 L/min
Smallest settable increment *2		0.01 L/min	0.1 L/min	0.1 L/min	0.1 L/min
Accumulated pulse flow rate exchange value		0.1 L/pulse	0.1 L/pulse	0.1 L/pulse	1 L/pulse
Indication unit *3		Instantaneous flow L/min, CFM x 10 ⁻² Accumulated flow L, ft ³ x 10 ⁻¹			
Accuracy		Display accuracy: ±3%F.S. Analog output accuracy: ±5%F.S. (Fluid: Dry air)			
Repeatability		±1%F.S. Analog output: ±3%F.S. (Fluid: Dry air)			
Pressure characteristics		±5%F.S. (0.35 MPa standard)			
Temperature characteristics		±2%F.S. (15 to 35°C) ±5%F.S. (0 to 50°C)			
Operating pressure range		-100 kPa to 750 kPa			
Rated pressure range		-70 kPa to 750 kPa			
Proof pressure		1 MPa			
Accumulated flow range		Max. 999999 L *4			
Switch output		NPN or PNP open collector output			
	Max. load current	80 mA			
	Max. applied voltage	28 VDC (at NPN output)			
	Internal voltage drop	NPN output: 1 V or less (at 80 mA), PNP output: 1.5 V or less (at 80 mA)			
	Response time	1 s (50 ms, 0.5 s, and 2 s can be selected.)			
	Output protection	Short-circuit protection			
Accumulated pulse output		NPN or PNP open collector output (Same as switch output)			
Analog output *5	Response time	1.5 s or less (90% response)			
	Voltage output	Voltage output: 1 to 5 V Output impedance: 1 kΩ			
	Current output	Current output: 4 to 20 mA Max. load impedance: 600 Ω, Min. load impedance: 50 Ω			
Hysteresis *6	Hysteresis mode	Variable			
	Window comparator mode	Variable			
External input		No-voltage input (Reed or Solid state), Input 30 ms or more			
Display method		3-digit, 7-segment LED 2-color display (Red/Green), Renewed cycle: 10 times/s			
Indicator LED		OUT1: Lights up when output is turned ON (Green), OUT2: Lights up when output is turned ON (Red)			
Power supply voltage		24 VDC ±10%			
Current consumption		55 mA or less			
Environment	Enclosure	IP40			
	Fluid temperature	0 to 50°C (No freezing or condensation)			
	Operating temperature range	Operating: 0 to 50°C Stored: -10 to 60°C (No freezing or condensation)			
	Operating humidity range	Operating/Stored: 35 to 85%R.H. (No condensation)			
	Withstand voltage	1000 VAC for 1 min between terminals and housing			
	Insulation resistance	50 MΩ or more (500 VDC measured via megohmmeter) between terminals and housing			
Standards		CE, UL (CSA), RoHS			
Main materials of parts in contact with fluid *7		LCP, PBT, HNBR, FKM, Si, Au, Stainless steel 304			
Weight		Straight: 70 g			
Cleanliness class (ISO class)		Class 4			

*1 When the smallest settable increment, 0.01 L/min, is selected for the 10 L/min type, the indication upper limit will be [9.99 L/min]. When the smallest settable increment, 0.1 L/min, is selected for the 100 L/min type, the indication upper limit will be [99.9 L/min].

*2 Users can select either 0.01 L/min or 0.1 L/min for the PFM710, and either 0.1 L/min or 1 L/min for the PFM711 respectively. If the indication unit is set to "CFM," the smallest settable increment cannot be changed. At the time of shipment from the factory, the smallest settable increment is set to 0.1 L/min for the PFM710 and 1 L/min for the PFM711 respectively.

*3 Set to "ANR" at the time of shipment from the factory. "ANR" is used for standard conditions: 20°C, 1 atm, and 65%R.H. "NL/min" is used for normal conditions: 0°C and 1 atm. When equipped with the units selection function. (The SI unit (L/min or L) is fixed for types with no units selection function.)

*4 This is cleared when the power supply is turned off. The hold function can be selected. (Intervals of 2 mins or 5 mins can be selected.)

If the 5 min interval is selected, the life of the memory device is limited to 1 million times. (If energized for 24 hours, life is calculated as 5 min x 1 million = 5 million min = 9.5 years). Therefore, if using the hold function, calculate the memory life for your operating conditions, and use within this life.

*5 Set to 1.5 s (90%), but can be changed to 100 ms.

*6 Set to hysteresis mode at the time of shipment from the factory. Can be changed to window comparator mode using push buttons.

*7 For details, refer to "Construction: Parts in Contact with Fluid" on page 8.

* For details about wiring and thread types, refer to the operation manual that can be downloaded from the SMC website (<http://www.smcworld.com>).

* Products with tiny scratches or display color or brightness variations which do not affect the performance of the product are verified as conforming products.



How to Order

Rated flow range:
2 to 200 L/min

PFMB 7 201 - 02 - A [] - M [] [] - X300

Rated flow range ●

201	2 to 200 L/min
-----	----------------

Port size ●

02	Rc1/4
----	-------

Output specification ●

	OUT1	OUT2
A	NPN	NPN
B	PNP	PNP
C	NPN	Analog 1 to 5 V
D	NPN	Analog 4 to 20 mA
E	PNP	Analog 1 to 5 V
F	PNP	Analog 4 to 20 mA
G	NPN	External input*1
H	PNP	External input*1

*1 Accumulated flow value, peak/bottom flow value can be reset by external signal input.

● Calibration certificate

Nil	None
A	Yes

* The certificate is written in English and Japanese. Other languages are available as a special order.

● Bracket

Nil	R
None	Bracket 10-ZS-33-M With 2 tapping screws
	T
	Panel mount adapter 10-ZS-33-J Panel mount adapter A Panel mount adapter B Mounting bracket Panel

* Bracket is shipped together with the product, but not assembled. If only brackets are required, refer to Bracket/Part Nos.

● Lead wire

Nil	W
Lead wire with connector (2 m) 10-ZS-33-D	Lead wire with connector (2 m) + Rubber cover for connector (Silicone rubber) 10-ZS-33-F 10-ZS-33-D
N	
Without lead wire with connector	* When only lead wires are required, refer to Lead Wire/Part Nos.

● Unit specification

M	Fixed SI unit*1
Nil	With units selection function*2

*1 Fixed unit: Instantaneous flow: L/min
Accumulated flow: L

*2 This product is for overseas use only according to the New Measurement Act. (The SI unit type is provided for use in Japan.)

DIN Rail Mounting Bracket (Ordered Separately)

10 - ZS - 33 - R []

Stations ●

1	1 station
2	2 stations
3	3 stations
4	4 stations
5	5 stations

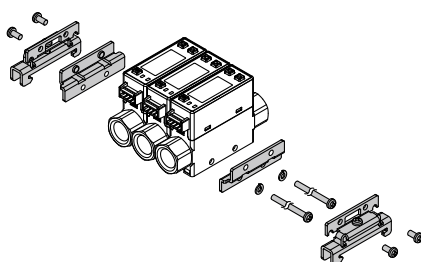

• The DIN rail should be provided by the customer.

● Lead Wire/Part Nos.

Option	Part no.	Qty.	Note
Lead wire with connector	10-ZS-33-D	1	Lead wire: 2 m
Rubber cover (Silicone rubber)	10-ZS-33-F	1	For connector

● Bracket/Part Nos.

Option	Part no.	Qty.	Note
Bracket	10-ZS-33-M	1	With 2 tapping screws (3 x 6)
Panel mount adapter	10-ZS-33-J	1	

PFMB7-X300

Refer to the **Web Catalog** for flow switch precautions. For details on the specific product precautions, refer to the "Operation Manual" on the SMC website.

Specifications: PFMB7-X300

Model		PFMB7201-X300	
Fluid	Applicable fluid*1	Dry air, N ₂ (Air quality grade is JIS B 8392-1 1.1.2 to 1.6.2, ISO 8573-1 1.1.2 to 1.6.2)	
	Fluid temperature range	0 to 50°C	
Flow	Detection method	Thermal type	
	Rated flow range	2 to 200 L/min	
	Set point range	Instantaneous flow	2 to 210 L/min
		Accumulated flow	0 to 999,999,999 L
	Smallest settable increment	Instantaneous flow	1 L/min
		Accumulated flow	1 L
	Accumulated volume per pulse (Pulse width = 50 ms)	1 L/pulse	
Accumulated value hold function*2	Intervals of 2 mins or 5 mins can be selected.		
Pressure	Rated pressure range	0 to 0.75 MPa	
	Proof pressure	1.0 MPa	
	Pressure characteristics*3	±5%F.S. (0 to 0.75 MPa, 0.35 MPa standard)	
Electrical	Power supply voltage	12 to 24 VDC±10%	
	Current consumption	55 mA or less	
	Protection	Polarity protection	
Accuracy*11	Display accuracy	±3%F.S.	
	Analog output accuracy	±3%F.S.	
	Repeatability	±1%F.S. (±2% F.S. when the response time is set to 0.05 s.)	
	Temperature characteristics	±5%F.S. (0 to 50°C, 25°C standard)	
Switch output	Output type	NPN open collector, PNP open collector	
	Output mode	Select from Hysteresis, Window comparator, Accumulated output, or Accumulated pulse output modes.	
	Switch operation	Select from Normal or Reversed output.	
	Max. load current	80 mA	
	Max. applied voltage (NPN only)	28 VDC	
	Internal voltage drop (Residual voltage)	NPN output type: 1 V or less (at load current of 80 mA), PNP output type: 1.5 V or less (at load current of 80 mA)	
	Response time*4	Select from 0.05 s, 0.1 s, 0.5 s, 1 s, or 2 s.	
	Hysteresis*5	Variable from 0	
Analog output*6	Output type	Voltage output: 1 to 5 V, Current output: 4 to 20 mA	
	Impedance	Voltage output	Output impedance: Approx. 1 kΩ
		Current output	Maximum load impedance at power supply voltage 24 V: 600 Ω, at power supply voltage 12 V: 300 Ω
	Response time*7	Linked to the response time of the switch output	
External input*8	External input	Input voltage: 0.4 V or less (Reed or Solid state) for 30 ms or longer	
	Input mode	Select from Accumulated value external reset or Peak/Bottom value reset.	
Display	Reference condition*9	Select from Standard conditions or Normal conditions.	
	Display mode	Select from Instantaneous flow or Accumulated flow.	
	Unit*10	Instantaneous flow	L/min or cfm can be selected.
		Accumulated flow	L or ft ³ can be selected.
	Display range	Instantaneous flow	-10 to 210 L/min (Displays [0] when value is within the -1 to 1 L/min range.)
		Accumulated flow	0 to 999,999,999 L
	Minimum display unit	Instantaneous flow	1 L/min
Accumulated flow		1 L	
Display	LED, Color: Red/Green, 3 digits, 7 segments		
Environment	Indicator LED	LED ON when switch output is ON (OUT1: Green, OUT2: Red)	
	Enclosure	IP40	
	Withstand voltage	1000 VAC for 1 min between terminals and housing	
	Insulation resistance	50 MΩ or more (500 VDC measured via megohmmeter) between terminals and housing	
Standards	Operating temperature range	Operating: 0 to 50°C, Stored: -10 to 60°C (No condensation or freezing)	
	Operating humidity range	Operating/Stored: 35 to 85%RH (No condensation or freezing)	
Piping	CE, UL (CSA), RoHS		
	Piping specification	Rc1/4	
Main materials of parts in contact with fluid*12	Piping entry direction	Straight	
		FKM, Stainless steel 304, PPS, PBT, HNBR, Si, Au, GE4F	
Weight	Rc1/4, Straight: 70 g		
Cleanliness class (ISO class)	Class 4		

*1 Refer to the "Example of recommended pneumatic circuit" in the Best Pneumatics catalog.

*2 When using the accumulated value hold function, use the operating conditions to calculate the product life, and do not exceed it. The maximum access limit of the memory device is 1 million times. If the product is operated 24 hours per day, the product life will be as follows:

- 5 min interval: life is calculated as 5 min x 1 million = 5 million min = 9.5 years
- 2 min interval: life is calculated as 2 min x 1 million = 2 million min = 3.8 years

If the accumulated value external reset is repeatedly used, the product life will be shorter than the calculated life.

*3 Do not release the OUT side piping port of the product directly to the atmosphere without connecting piping. If the product is used with the piping port released to atmosphere, accuracy may vary.

*4 The time from when the flow is changed by a step input (when the flow rate changes from 0 to the maximum value of the rated flow range instantaneously) until the switch output turns ON (or OFF) when set at 90% of the rated flow rate

*5 If the flow fluctuates around the set value, be sure to keep a sufficient margin. Otherwise, chattering will occur.

*6 When using a product with an analog output

*7 The time from when the flow is changed by a step input (when the flow rate changes from 0 to the maximum value of the rated flow range instantaneously) until the analog output reaches 90% of the rated flow rate

*8 When using a product with an external input

*9 The flow rate given in the specifications is the value under standard conditions.

*10 Can be selected only for models with the unit selection function.

*11 For details, refer to "Straight Piping Length and Accuracy" in the Best Pneumatics catalog.

*12 For details, refer to "Construction: Parts in Contact with Fluid" on page 8.

* Products with tiny scratches or display color or brightness variations which do not affect the performance of the product are verified as conforming products.

Set Point Range and Rated Flow Range

Set the flow rate within the rated flow range.

The set point range is the range of flow rate that can be set in the switch.

The rated flow range is the range that satisfies the switch specifications (accuracy, linearity, etc.).

It is possible to set a value outside of the rated flow range if it is within the set point range, however, the satisfaction of specifications can not be guaranteed. The flow range if using CO₂ is given in brackets.

PFM7-X300

Model	Flow range												
	-10 L/min	0 L/min	0.2 L/min	0.5 L/min	1 L/min	2 L/min	10 L/min	25 L/min	50 L/min	100 L/min	200 L/min		
PFM710		0.2 L/min	Rated flow range					10 L/min (5 L/min)					
		0.2 L/min	Set point range					10.5 L/min (5.2 L/min)					
		0	Display range					10.5 L/min (5.2 L/min)					
PFM725		0.5 L/min	Rated flow range					25 L/min (12.5 L/min)					
		0.5 L/min	Set point range					26.3 L/min (13.1 L/min)					
		0	Display range					26.3 L/min (13.1 L/min)					
PFM750			1 L/min	Rated flow range					50 L/min (25 L/min)				
			1 L/min	Set point range					52.5 L/min (26.2 L/min)				
			0	Display range					52.5 L/min (26.2 L/min)				
PFM711				2 L/min	Rated flow range					100 L/min (50 L/min)			
				2 L/min	Set point range					105 L/min (52 L/min)			
				0	Display range					105 L/min (52 L/min)			

PFMB7-X300

Model	Flow range											
	-10 L/min	0 L/min	0.2 L/min	0.5 L/min	1 L/min	2 L/min	10 L/min	25 L/min	50 L/min	100 L/min	200 L/min	
PFMB7201						2 L/min	Rated flow range					200 L/min
						2 L/min	Set point range					210 L/min
		-10 L/min	Display range									

Analog Output

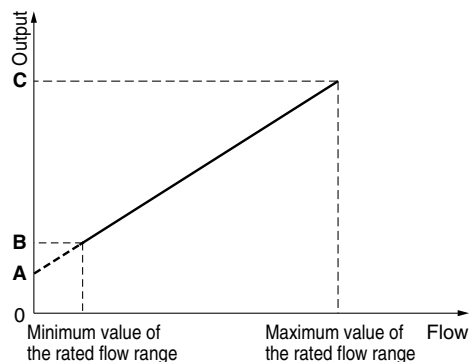

Flow/Analog Output

Model		A	B	C
		Voltage output	1 V	—
PFM7-X300	Current output	4 mA	—	20 mA
	Voltage output	1 V	1.04 V	5 V
PFMB7-X300	Current output	4 mA	4.16 mA	20 mA

Model	Minimum value of the rated flow range [L/min]	Maximum value of the rated flow range [L/min]
PFM710-X300	0.2	10 (5)
PFM725-X300	0.5	25 (12.5)
PFM750-X300	1	50 (25)
PFM711-X300	2	100 (50)
PFMB7201-X300	2	200

* (): Fluid: CO₂

* Analog output at maximum rated flow rate when CO₂ is selected for the PFM7-X300 is 3 [V] for the voltage output type and 12 [mA] for the current output type.

PFM7/PFMB7-X300

Internal Circuits and Wiring Examples

-A NPN (2 outputs)

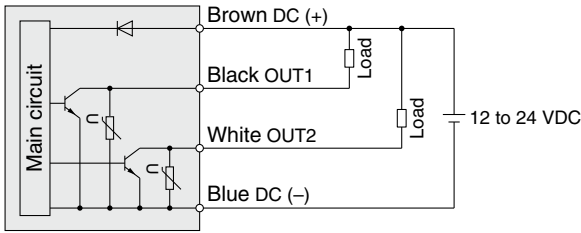

Max. applied voltage: 28 V, Max. load current: 80 mA,
Internal voltage drop: 1 V or less

-B PNP (2 outputs)

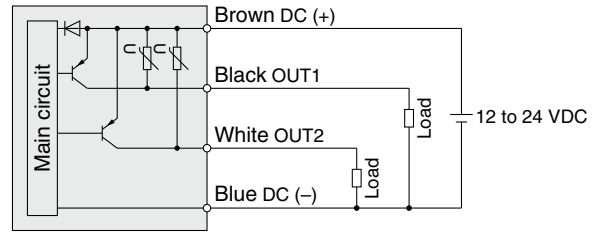

Max. load current: 80 mA, Internal voltage drop: 1.5 V or less

-C/D C: NPN (1 output) + Analog voltage output D: NPN (1 output) + Analog current output

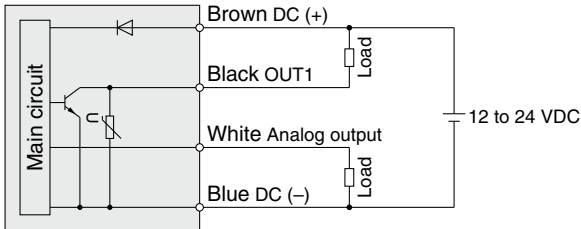

Max. applied voltage: 28 V, Max. load current: 80 mA,
Internal voltage drop: 1 V or less
C: Analog output: 1 to 5 V
Output impedance: 1 k Ω
D: Analog output: 4 to 20 mA
Max. load impedance: 600 Ω

-E/F E: PNP (1 output) + Analog voltage output F: PNP (1 output) + Analog current output

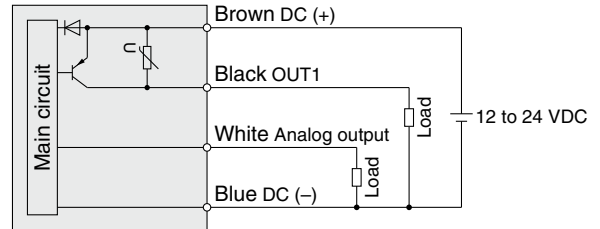

Max. load current: 80 mA, Internal voltage drop: 1.5 V or less
E: Analog output: 1 to 5 V
Output impedance: 1 k Ω
F: Analog output: 4 to 20 mA
Max. load impedance: 600 Ω

-G NPN (1 output) + External input

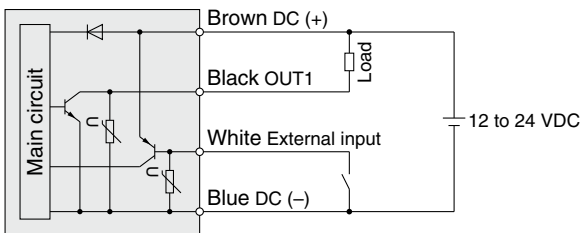

Max. applied voltage: 28 V, Max. load current: 80 mA,
Internal voltage drop: 1 V or less
External input: Input voltage 0.4 V or less (Reed or Solid state input)
for 30 ms or longer

-H PNP (1 output) + External input

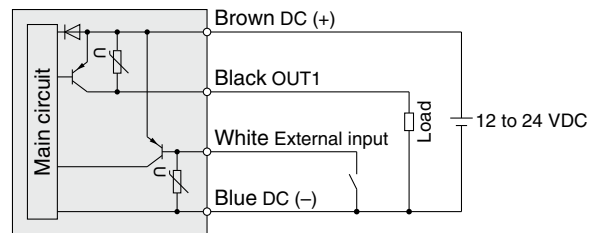

Max. load current: 80 mA, Internal voltage drop: 1.5 V or less
External input: Input voltage 0.4 V or less (Reed or Solid state input)
for 30 ms or longer

Accumulated pulse output wiring examples

-A/C/D/G

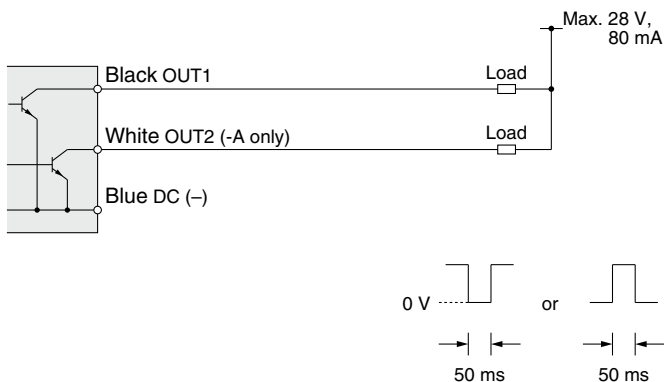

-B/E/F/H

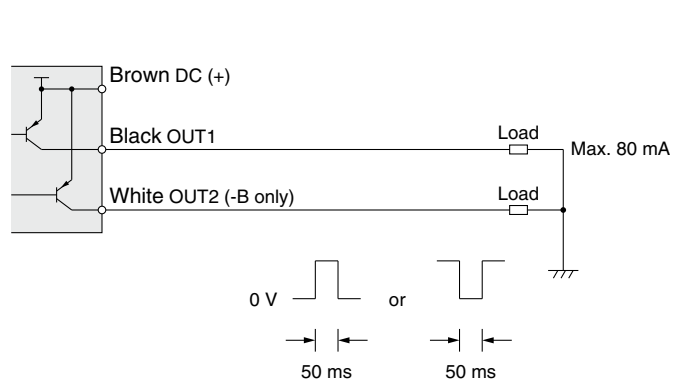

Construction: Parts in Contact with Fluid

PFM7-X300

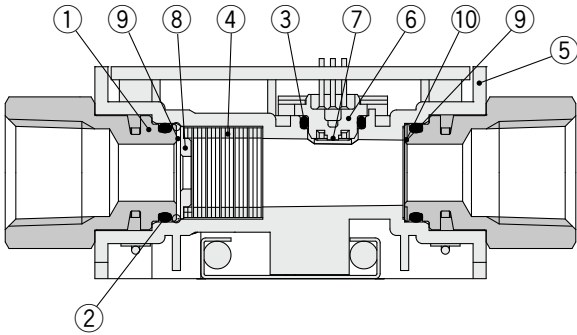

Component Parts

No.	Description	Material	Note
1	Fitting for piping	Stainless steel 304	
2	O-ring	FKM	Fluoro coating
3	O-ring	HNBR	Fluoro coating
4	Rectifying module	Stainless steel 304	
5	Body	PBT	
6	Sensor housing	LCP	
7	Sensor chip	Silicon	
8	Orifice	Stainless steel 304	
9	Seal	FKM	Fluoro coating
10	Mesh	Stainless steel 304	

PFMB7-X300

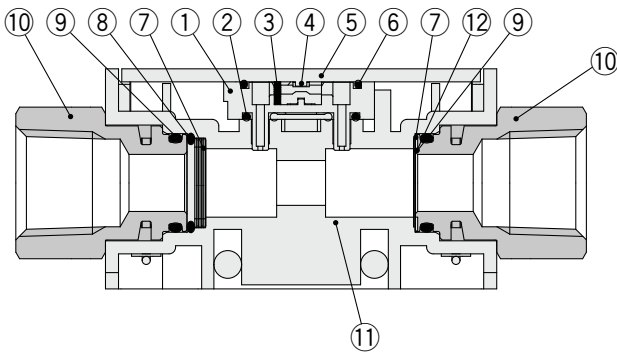

Component Parts

No.	Description	Material	Note
1	Sensor body	PPS	
2	Gasket	HNBR	
3	Flow rectifier	Stainless steel 304	
4	Sensor chip	Silicon	
5	Printed circuit board	GE4F	
6	Gasket	HNBR	
7	Flow rectifier	Stainless steel 304	
8	O-ring	FKM	Fluoro coating
9	O-ring	FKM	Fluoro coating
10	Fitting for piping	Stainless steel 304	
11	Body	PBT	
12	Gasket	HNBR	

Dimensions

PFM710/750/711-□-X300
PFMB7201-02-X300

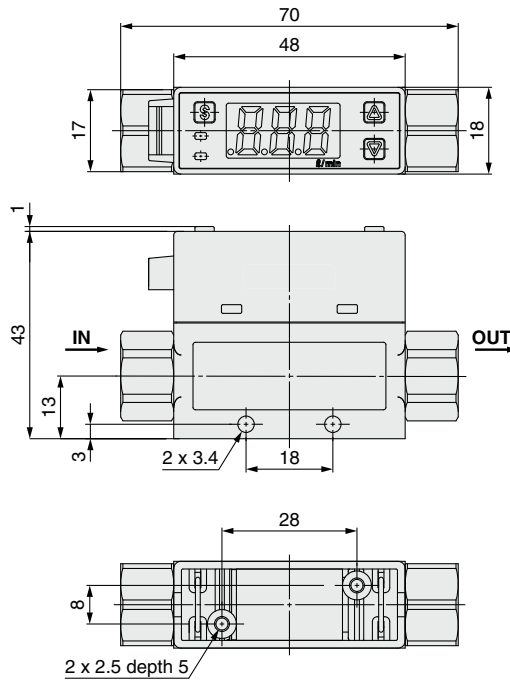
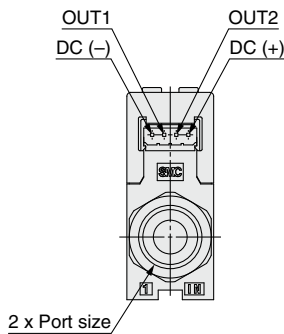

Model	Port size (Rc)
PFM710	1/8
PFM725	1/8
PFM750	1/8
PFM711	1/4
PFMB7201	1/4

⚠ Precautions

Flush the piping line before when the product for the first time and after it has been replaced. Also, if piping, etc., is to be connected, flush (air blow) using this product for the first time in order to reduce the effects of the dust generated from the connection, etc. Flushing the line is also required to eliminate contamination resulting from the installation of piping lines. Therefore, be sure to flush the line before running the system. Make sure all mounting parts are secure before use.

 **Safety Instructions** Be sure to read the "Handling Precautions for SMC Products" (M-E03-3) and "Operation Manual" before use.