

**IO-Link Compatible** **3-Screen Display**

**New**

# Digital Gap Checker



**Displayed value**

Converted value of the gap distance (Reference) 16-bit data

**Monitoring the placement condition of the workpiece**  
**Indicates failure/abnormality**

**Supply pressure value**

Product supply pressure (SUP) 16-bit data

**Outlet pressure value**

Detection nozzle side pressure (Back pressure) 16-bit data

## NPN/PNP Switch Function

Both NPN and PNP are available.

The number of stock items can be reduced.



## 3-Screen Display (Setting)

Upper 4-digit Lower 4-digit x 2-screen



## Window Comparator Type

The gap range is adjustable.

$50 \leq \text{Pass} \leq 70$



**Existing**

Checked only "Placed" or "Not placed"

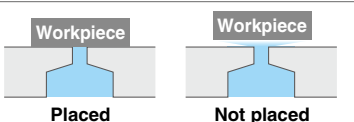

## Zero cut-off range can be changed.

The lower limit of the display/setting range has been extended.

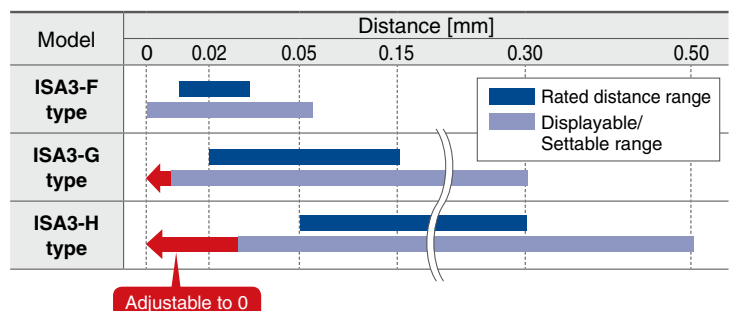

# ISA3-L Series



CAT.ES100-125A

# Double sensor providing improved preventive and predictive maintenance (IoT) based on IO-Link

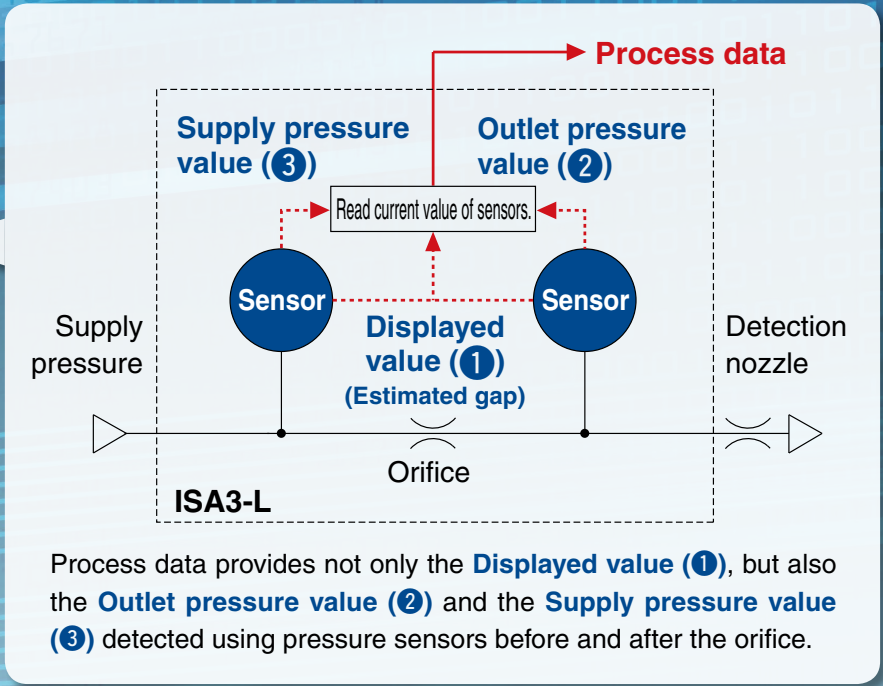

Process data provides not only the **Displayed value (1)**, but also the **Outlet pressure value (2)** and the **Supply pressure value (3)** detected using pressure sensors before and after the orifice.

## Process Data

Item	Gap size (Reference): 16 Bit signed integer															
Bit offset	63	62	61	60	59	58	57	56	55	54	53	52	51	50	49	48
Item	Supply pressure value: 16 Bit signed integer															
Bit offset	47	46	45	44	43	42	41	40	39	38	37	36	35	34	33	32
Item	Outlet pressure value: 16 Bit signed integer															
Bit offset	31	30	29	28	27	26	25	24	23	22	21	20	19	18	17	16
Item	Error diagnosis	0						Pressure diagnosis	0		Outlet side SW2	Outlet side SW1	Supply side SW2	Supply side SW1	Distance detection SW2	Distance detection SW1
Bit offset	15	14	13	12	11	10	9	8	7	6	5	4	3	2	1	0

**Diagnosis item**

- Abnormal temperature
- Display pressure range has exceeded the lower limit
- Internal product malfunction
- Outside of zero-clear range

**Diagnosis item**

- Detected pressure: Less than -20 kPa

## Example of Detection Applications Using the Switching Outputs and Value

Setting example	Outlet pressure value		Supply pressure value		Displayed value (Gap size)		Diagnosis item
	SW2	SW1	SW2	SW1	SW2	SW1	
Mode	Hysteresis	Window comparator	Hysteresis	Hysteresis	Hysteresis	Hysteresis	
Setting contents	Turns ON at 5 kPa or less	Turns ON at 25 to 50 kPa	Turns ON at 200 kPa or more	Turns ON at 100 kPa or less	Turns ON at 150 μm or less	Turns ON at 50 μm or less	
Output status	—	—	—	—	○	○	Confirmation of close contact: 50 μm or less
	—	—	—	—	○	—	Confirmation of approximate contact: 150 μm or less
	—	—	—	○	—	—	Insufficient supply pressure: 100 kPa or less
	—	—	○	—	—	—	Excessive supply pressure: 200 kPa or more
	○	○	—	—	—	—	Detection nozzle clogging
	○	—	—	—	—	—	Orifice clogging

○: The corresponding bit in the process data is "1:ON" —: The corresponding bit in the process data is "0:OFF" or not determined

**Process data provides (1) Displayed value, (2) Outlet pressure and (3) Supply pressure value.**

Not only the displayed value, but also the pressure value (supply pressure, outlet pressure) which affect the detection can be transmitted in real time.

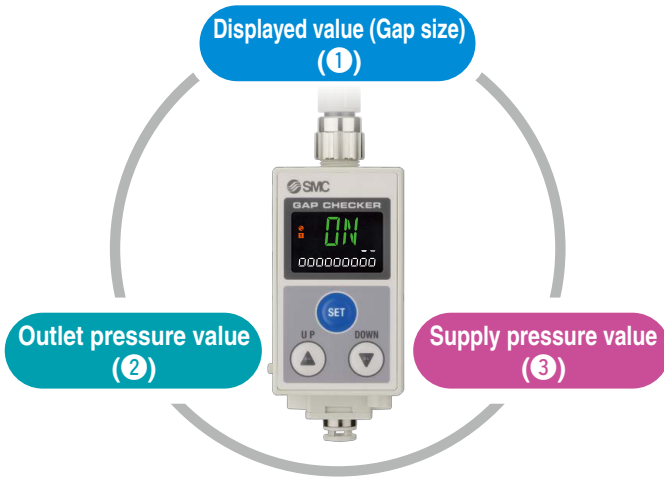

The displayed value is converted value of the gap distance and is a guideline.

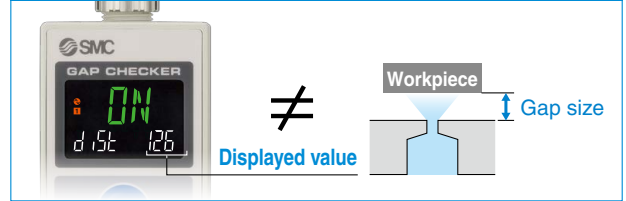

The relationship between the displayed value (gap distance guideline) and detection nozzle clogging/orifice clogging

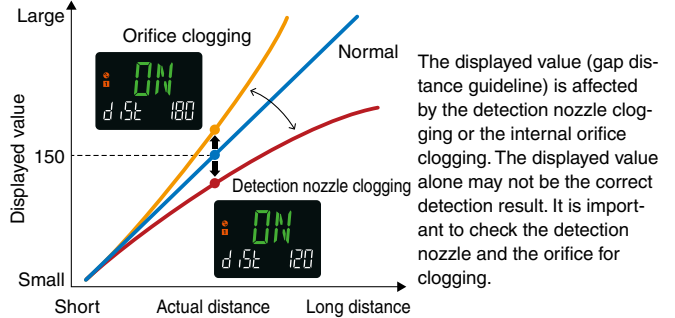

The displayed value (gap distance guideline) is affected by the detection nozzle clogging or the internal orifice clogging. The displayed value alone may not be the correct detection result. It is important to check the detection nozzle and the orifice for clogging.

**Monitoring of the outlet pressure value**

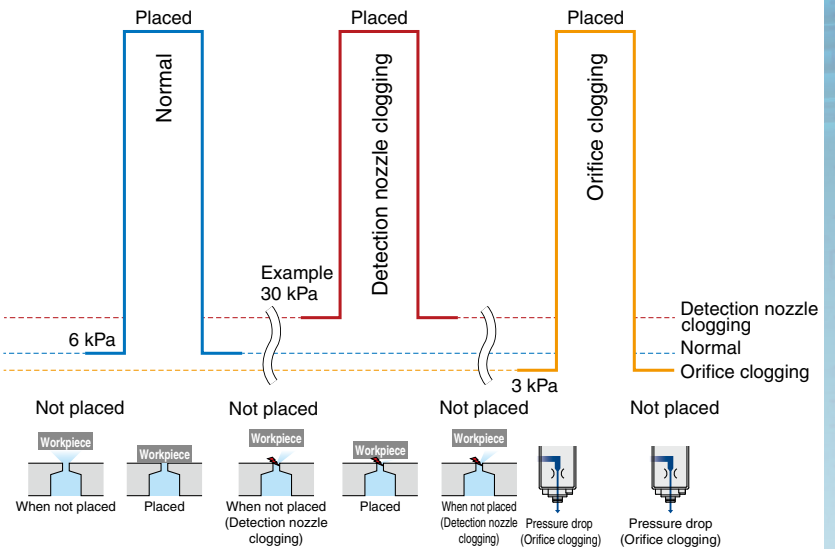
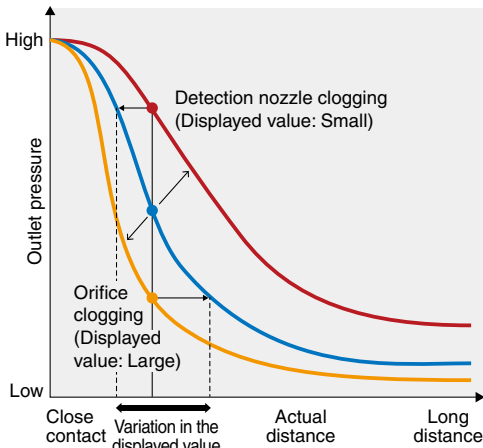

The displayed value varies if the detection nozzle or internal orifice is clogged. It is possible to detect clogging by monitoring the outlet pressure during workpiece transfer (the workpiece is not placed).

**Monitoring of the supply pressure value**

Change of the outlet pressure when the supply pressure changes

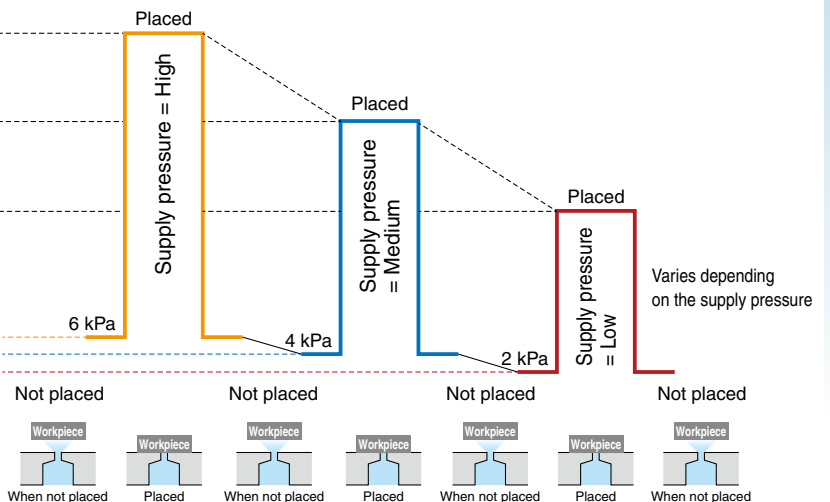
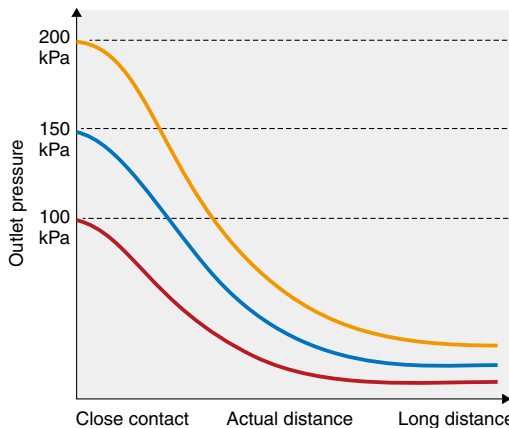

The outlet pressure while the workpiece is being transferred (not placed) also varies depending on the supply pressure. The supply pressure and the outlet pressure need to be monitored simultaneously.



IO-Link is an open communication interface technology between the sensor/ actuator and the I/O terminal that is an international standard, IEC61131-9.

## Visualization of operation/equipment status Remote monitoring and control by communication

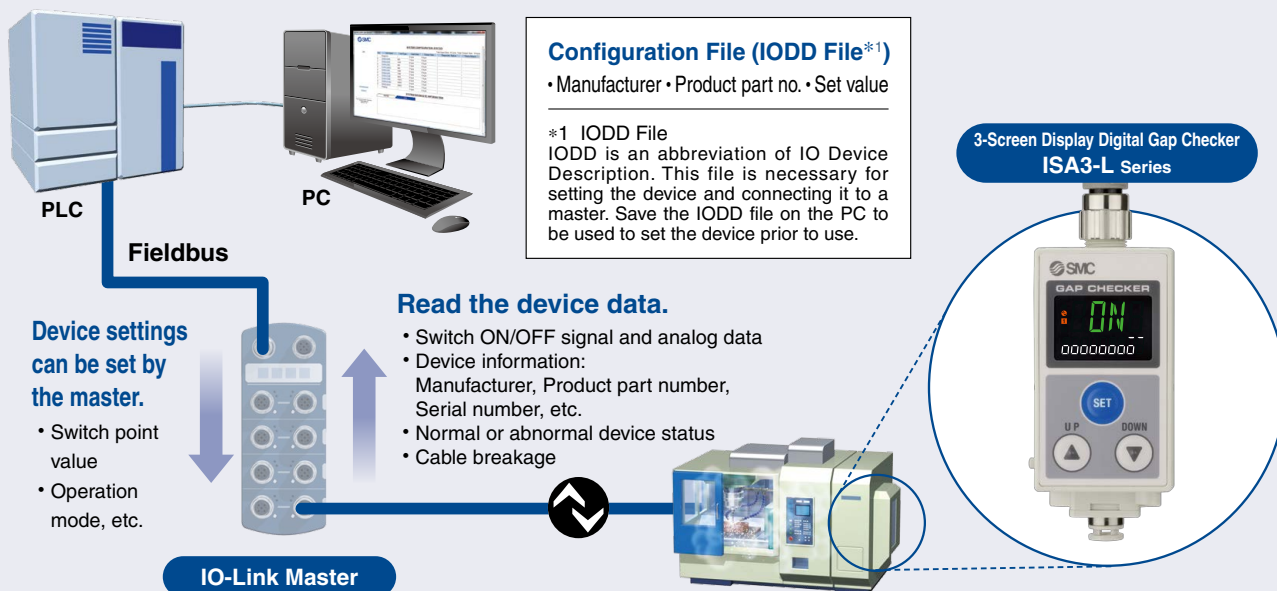

### Automatic setting function [Data storage function]

When replacing the sensor with the same type (the same device ID), the parameters (set values) stored in the IO-Link master are automatically copied (set) to the new sensor.

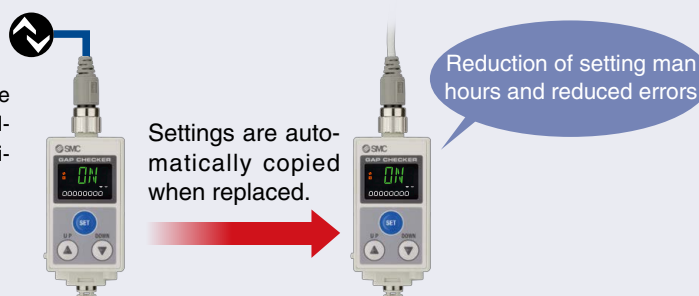

Displays the output communication status and indicates the presence of communication data



### Operation and Display

Communication with master	IO-Link status indicator light	Status	Screen display *2	Description	
Yes	*1	Normal	Operate	Mode oPE	Normal communication status (readout of measured value)  At the start of communication
			Start up	Mode Strt	
			Preoperate	Mode PrE	
No	*1 (Flashing)	Abnormal	Version does not match	Er 15 1/10	IO-Link version does not match that of the master. The master uses version 1.0. * The applicable IO-Link version is 1.1.
			Communication disconnection	Mode oPE Mode Strt Mode PrE	
	OFF	SIO mode	Mode S10	General switch output	

\*1 In IO-Link mode, the IO-Link indicator is ON or flashes. \*2 When the sub screen is set to Mode  
 \* "ModE LoC" is displayed when the data storage lock is enabled. (Except for version mismatch or when in SIO mode)

## Sub display improved for ease of use

### Pressure resolution improved

Values can be checked up to 0.1 kPa using 4-digits display.



### Line name display

Required characters string of 4 digits can be entered (up to 9 digits can be input) using a dual display.



### Level meter digits increased

6 digits → 9 digits



Status can be checked in more detail due to the increase of the level meter digits.

IO-Link Compatible **ISA3-L Series**

Level meter digits increased: **9 digits**

**ISA3 Series**

Number of level meter digits: **6 digits**



When the workpiece is away from the detection surface, the level meter will not reach the switch point value bar.

When the workpiece is seated on the detection surface, the level meter will reach the switch point value bar.

When the workpiece is away from the detection surface, the level meter will not reach the switch point value bar.

When the workpiece is seated on the detection surface, the level meter will reach the switch point value bar.

The number of level meter symbols changes depending on the clearance between the workpiece and the detection surface. Even clearances which cannot be visually confirmed are indicated on the display.

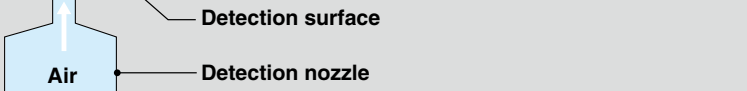

\*1 The displayed value (estimated gap distance) will vary depending on individual product differences and nozzle machining dimensions.

## 3-Step Setting (Switch Point Change Mode)

- Simple setting of the switch point value (point at which the clearance reaches the switch point value)

**Snap shot function**  
Pressing the ▲ and ▼ buttons simultaneously for a minimum of 1 second then releasing the buttons when the displayed switch point value disappears will make the switch point the same as the current displayed value.

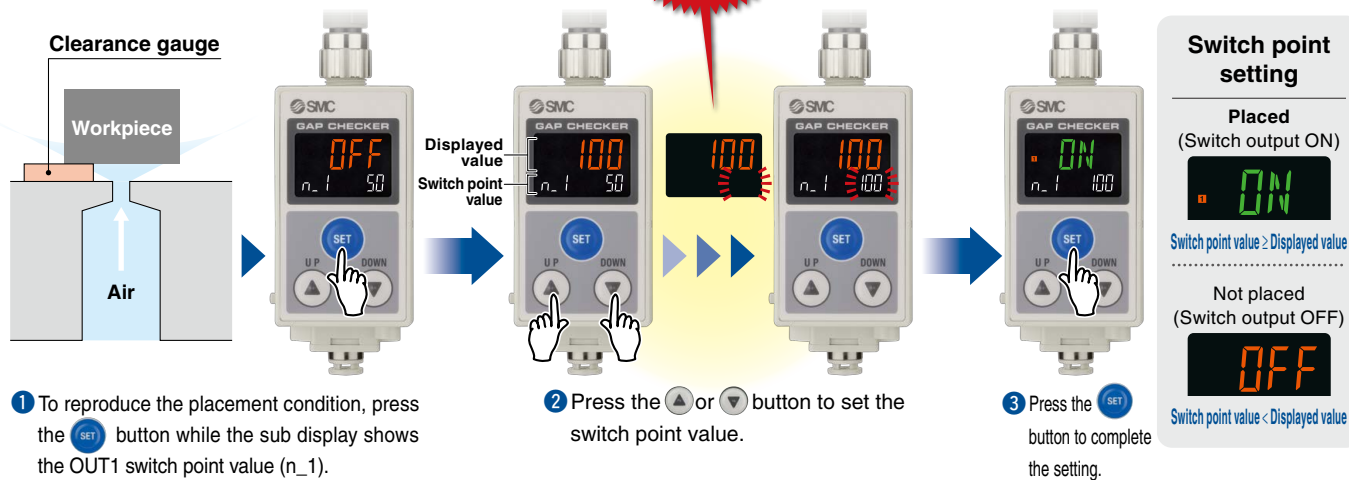

- To reproduce the placement condition, press the SET button while the sub display shows the OUT1 switch point value (n\_1).
- Press the ▲ or ▼ button to set the switch point value.
- Press the SET button to complete the setting.

\* Operation is different from products which are not IO-Link compliant (1 output, 2 outputs type).

## 3-Screen Digital Display

- The seating condition can be checked at a glance. The sub screen can display 1 of 12 display options.

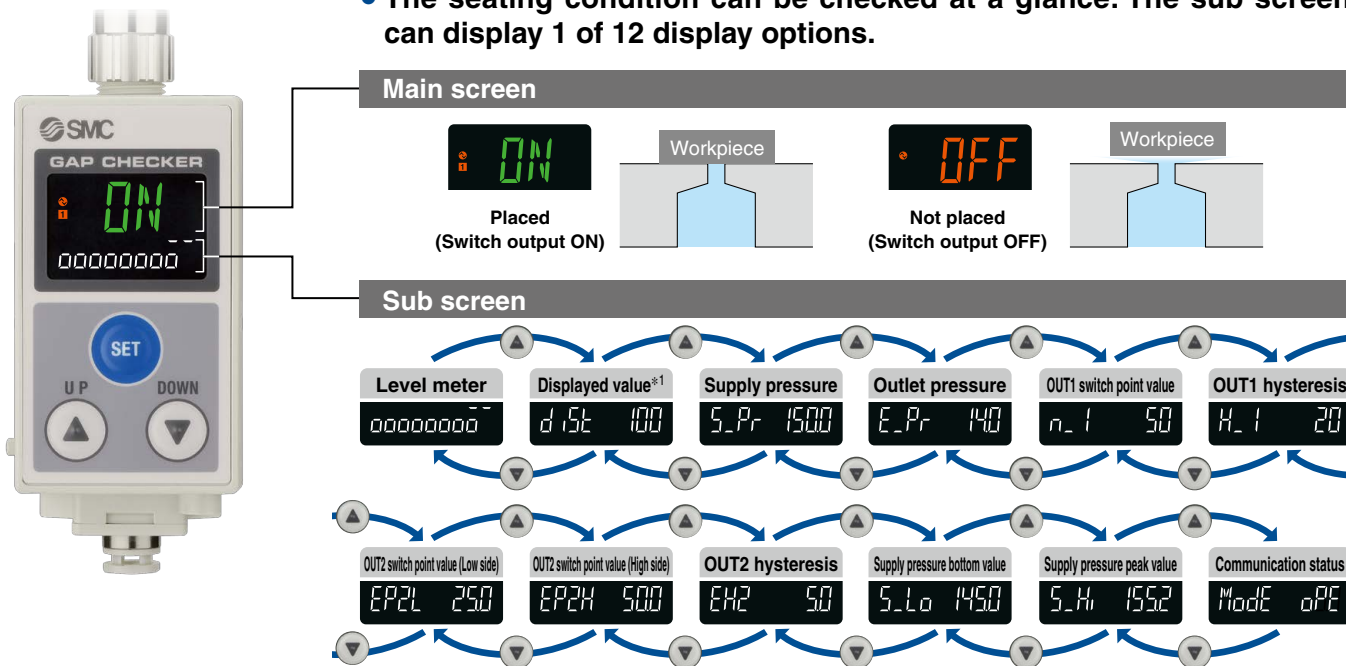

\*1 The displayed value is a reference value obtained by converting the distance between the workpiece and the detection surface into a digital numerical value. It is not displayed in units. For details, refer to the Relationship Between Displayed Value and Distance on page 18.

## Rated Distance Range: 3 types are available.

Model	Distance [mm]					
	0	0.02	0.05	0.15	0.30	0.50
ISA3-F type	Rated distance range		Displayable/ Settable range			
ISA3-G type	When zero cut-off is minimum		Rated distance range			
ISA3-H type	When zero cut-off is minimum		Rated distance range			

### 3 Setting Modes

Select the setting mode that best meets your needs.

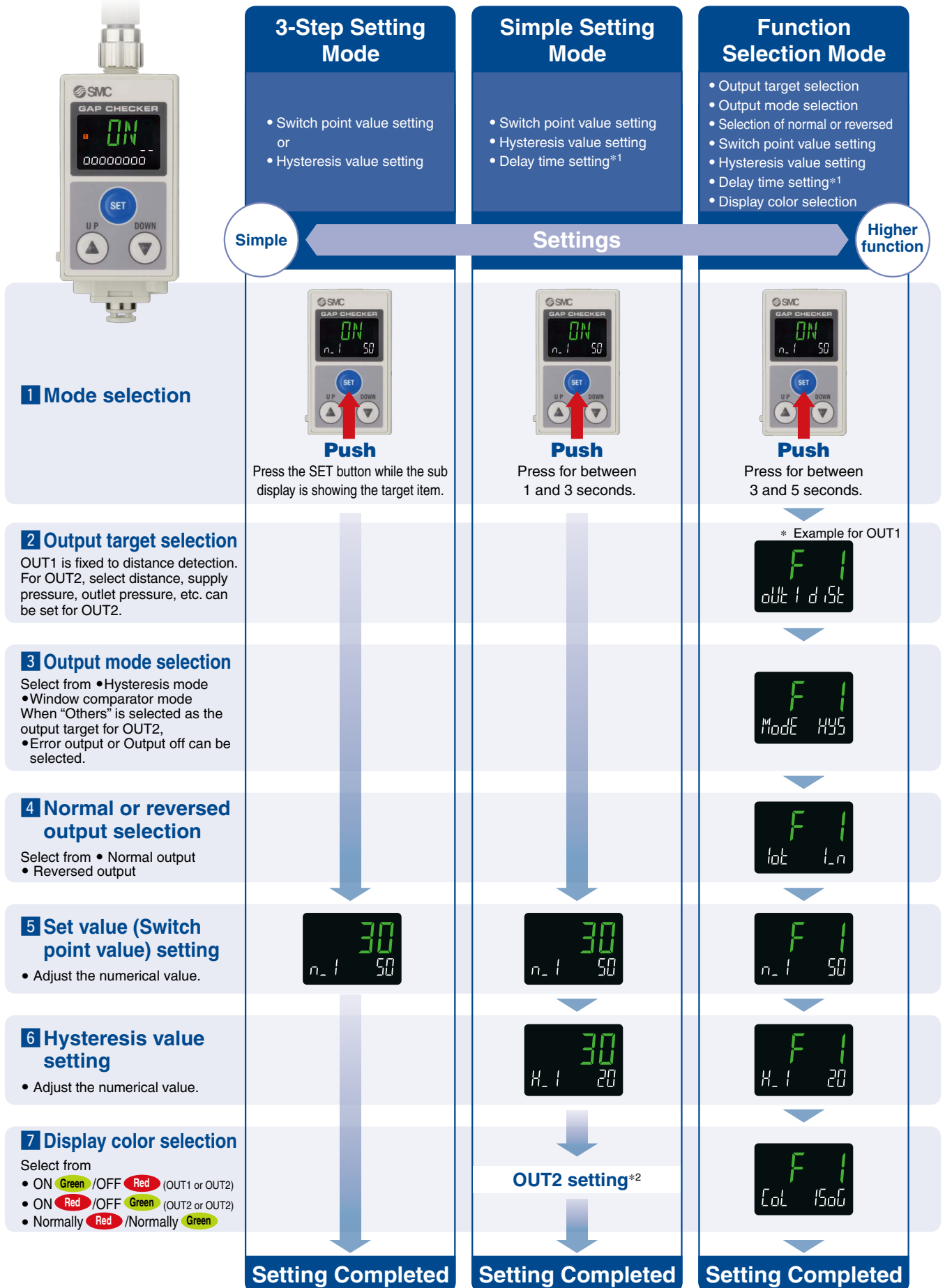

\*1 Available when OUT2 is not set for "distance." It can be set in the next step of the Hysteresis value setting.

\*2 Refer to the Operation Manual for details on setting the OUT2.

## 2 Outputs Type

- (1) Displayed value, (2) Outlet pressure value, and (3) Supply pressure value can be selected in OUT2.



The pressure and gap size are detected by the pressure sensors at the front and back of the orifice before output.

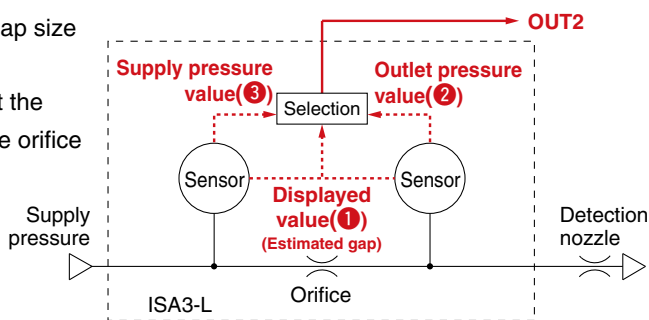

## Monitoring of the Outlet Pressure Value (2)

- **OUT2 detection of rising pressure when a workpiece is not placed that signifies detection nozzle clogging.**

Only nozzle clogging is detected by the window comparator mode and setting the response time.

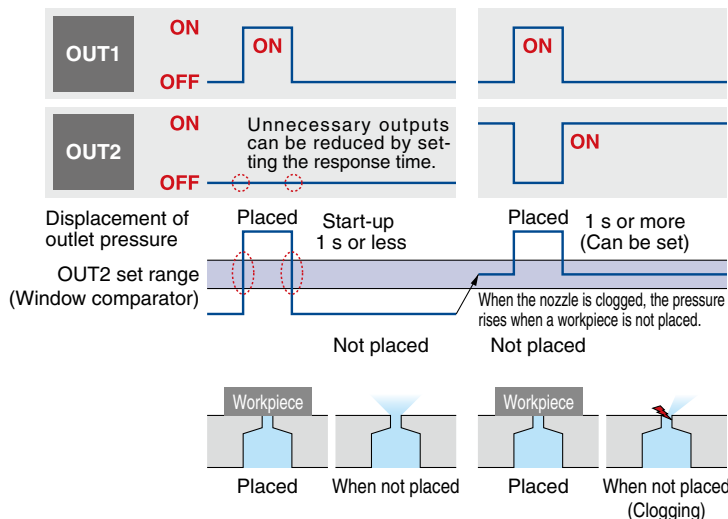

- **Can discern between 2 different types of workpiece**

Can detect raw material workpieces and defective workpieces via the pressure (OUT2)

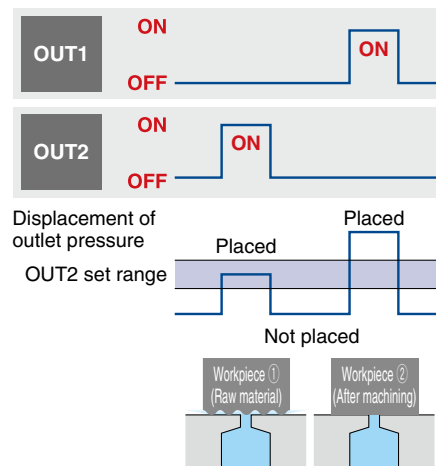

## Monitoring of the Displayed Value (Gap Size) (1)

- **Can discern between 2 different types of workpiece**

Can detect the difference between raw material workpieces and defective workpieces via the gap size

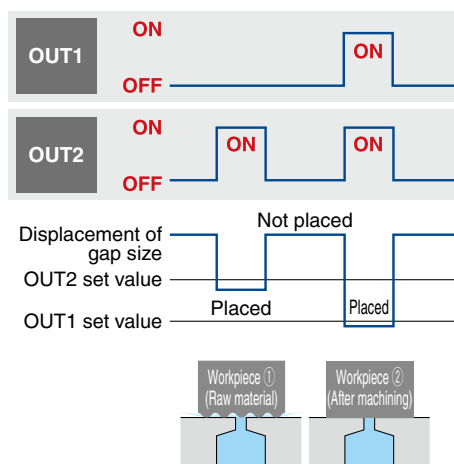

## Monitoring of the Supply Pressure Value (3)

- **Detection of rated pressure range via OUT2**

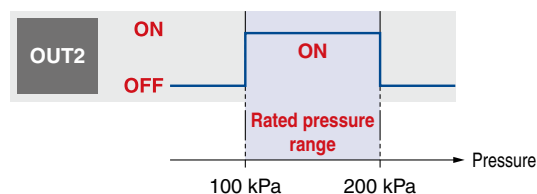



## Improved Environmental Resistance

### Easier maintenance

The internal orifice part can be removed for cleaning. It is not necessary to remove the piping or metal connection fitting for cleaning even when the product is installed in the user's equipment.



\* Once the orifice has been removed, the switch point will need to be set again.

### Measures against drainage

**Drainage resistance:** increased by **10 times or more**

\* Based on SMC's specific testing conditions (Oil proof test)  
\* Compared with the ISA2

### Withstand pressure increased by

**Max.: 600 kPa**

3 times\*1 compared with the ISA2

\*1 Compared with the ISA2 with a 0.2 MPa pressure gauge

### High-pressure flushing

\* The switch output will be OFF during flushing.

## Noise reduction, Energy saving, Measures against clogging

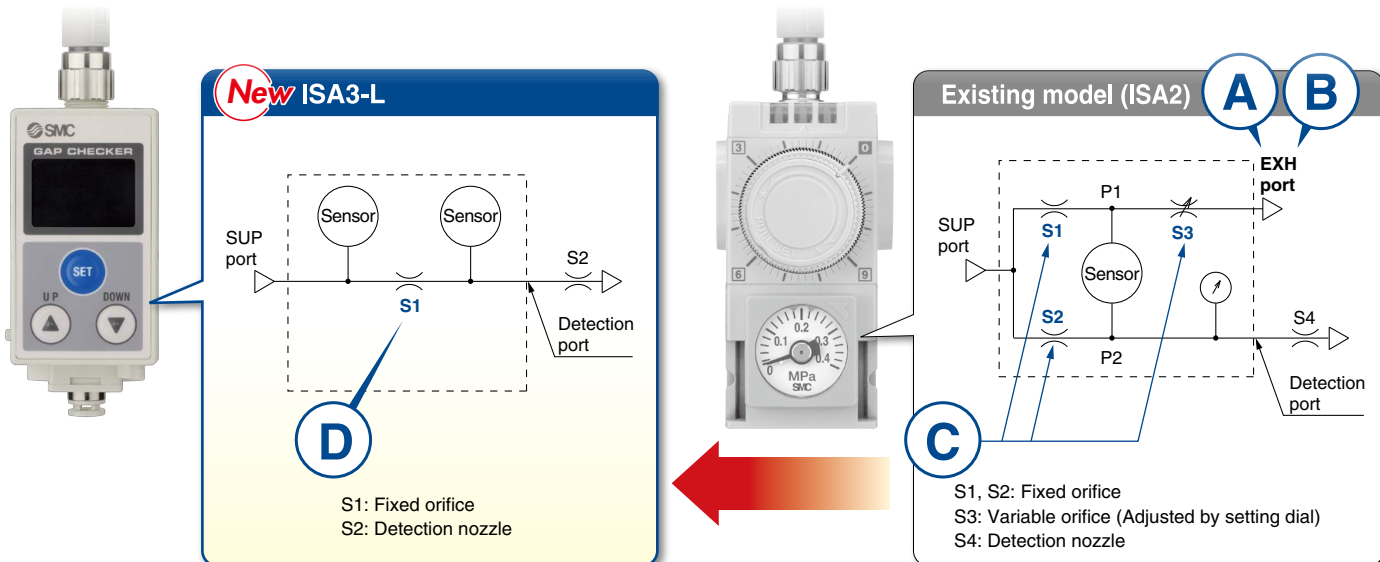

### A Exhaust noise: **Zero**

#### Noise reduction

The existing model (ISA2) needs to exhaust air from the exhaust port due to its bridge circuit. However, the ISA3 does not exhaust air from the product body. This reduces noise considerably compared with the existing model.

### B Air consumption: **60% reduction**\*1

#### Energy saving

The new detection principle eliminates the need for air to be exhausted from the product. This makes the flow consumption 0 L/min when a workpiece is seated. The result is a great reduction in air consumption compared with the existing model.

\*1 Conditions: Unseated for 5 seconds and seated for 20 seconds (For the G type)

### C Number of orifices: **3 → 1**

#### Measures against clogging

By reducing the number of internal orifices from 3 to 1, there is less possibility of fluctuations in the output due to clogging. By removing the setting dial for S3, fluctuations in the detection distance can be prevented.

### D Orifice area ratio: **68% increase**\*1

#### Measures against clogging

A larger orifice area lowers the possibility of clogging. However, even if the orifice does become clogged with foreign matter, the product construction allows for the internal orifice to be removed for cleaning.

\*1 Excludes the F type

## Compact & Lightweight

- Volume: **40% reduction**

Weight: **55% reduction**

(Comparison between the ISA3-GC and the existing model ISA2 with One-touch fitting)

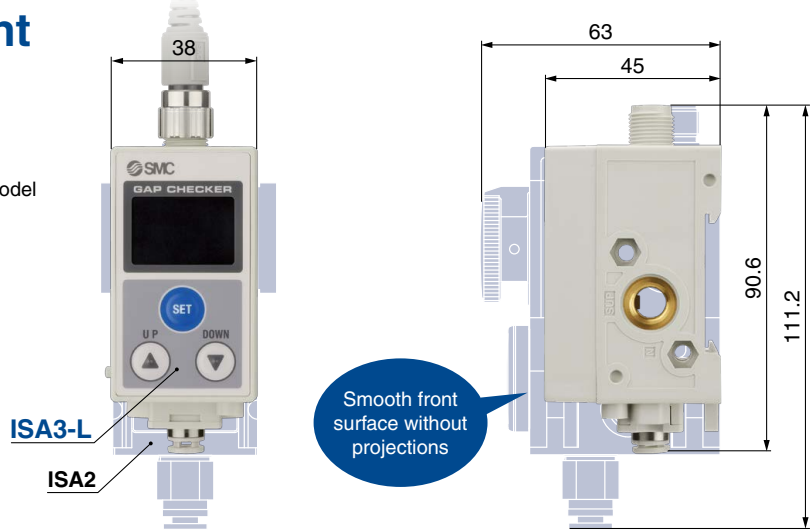

## Space saving and man-hour reduction by centralized lead wires

- Installation space: **30 mm reduction**

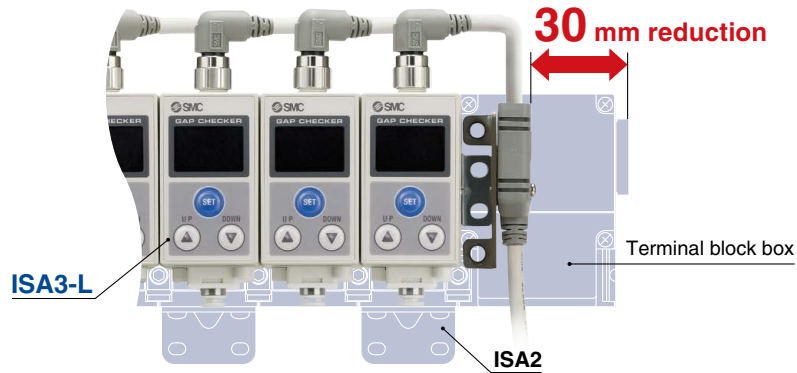

- Requires less wiring labor

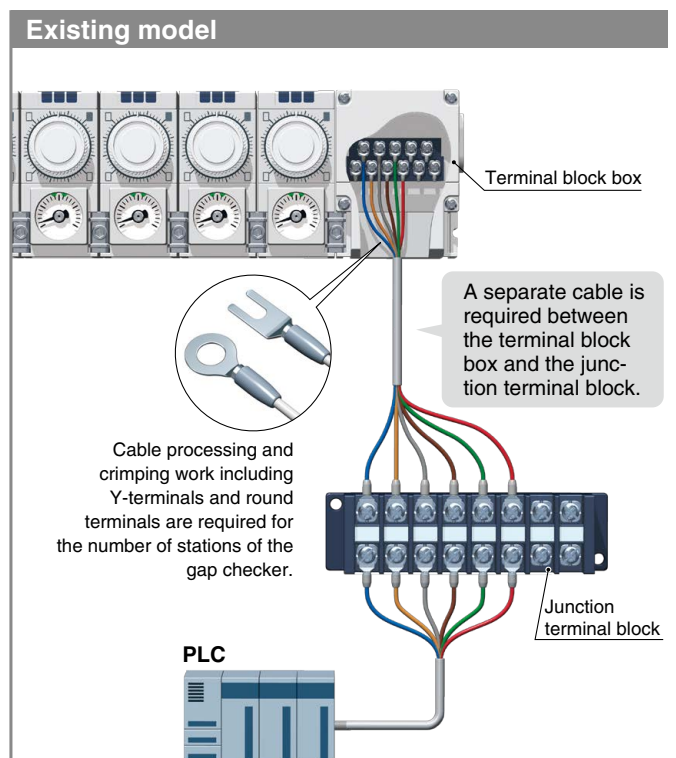
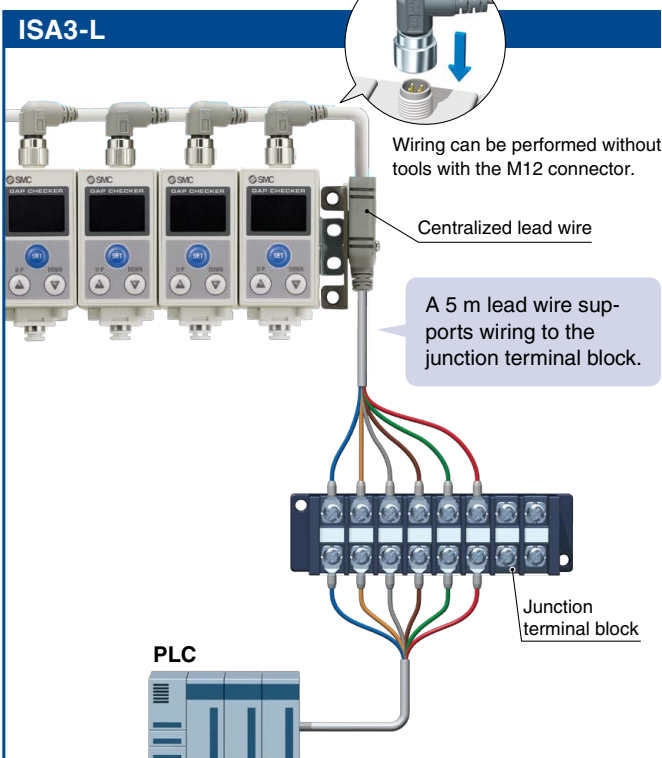

## Keylock Function

- A key LED turns ON when the product is locked and button operation is disabled to prevent unintentional changes to set values.

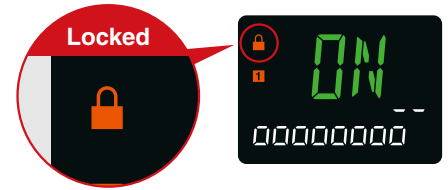

## Piping Variations

Piping specification: C type



Piping specification: F type



## Mounting

Bracket



DIN rail



## Manifold

With control unit

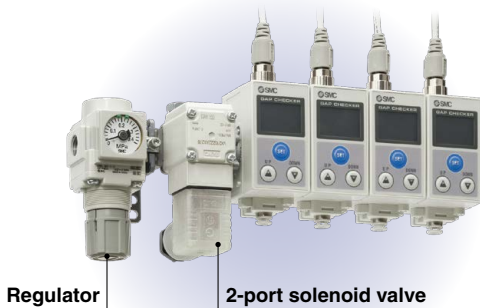

\* Bracket mounting only

Without control unit



Supply port: Left side



Supply port: Right side



\* The electrical entry of the centralized lead wire for the M12 connector is on the right side.  
When using a right-sided supply port, arrange the centralized lead wire so that it does not interfere with the control unit.

## Application Examples

### • Detection of the table and pallet seating

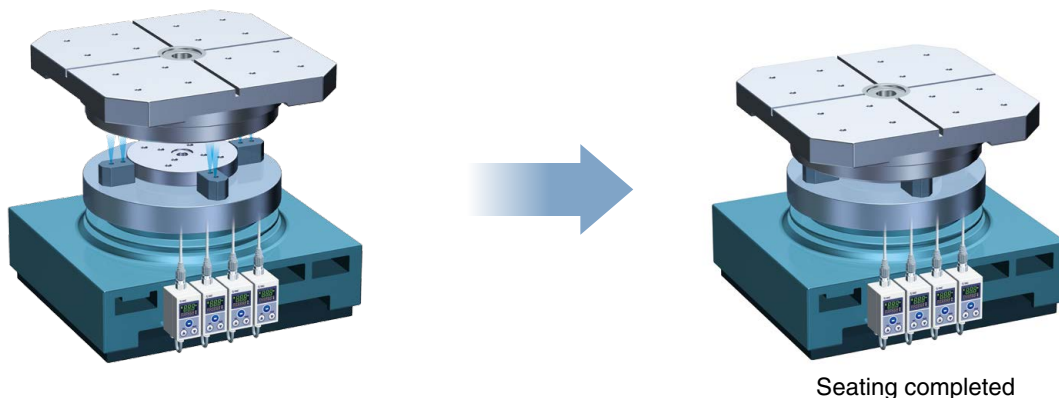

### • Workpiece clamp detection

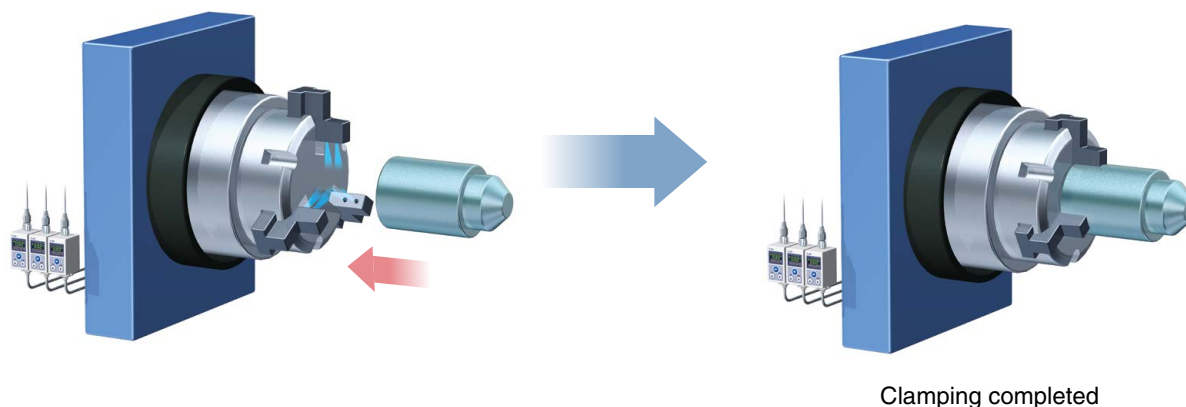

## Main Functions

### ■ Display OFF mode

Display OFF mode can be selected. The display can be turned OFF to reduce power consumption.



The numerical value disappears and only the decimal points blink.

### ■ Security code

When the security code is activated, the code needs to be entered before the product can be operated.

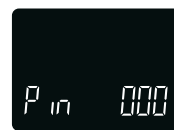

Security code: Input an arbitrary 3-digit code.

### ■ Display color

The color of the main display can be set to change depending upon the output activity. The display color change makes visual identification of the output ON/OFF easier.

When ON: Green When OFF: Orange

When ON: Orange When OFF: Green

Normally: Orange

Normally: Green

### ■ Displayed value compensation

The displayed value can be corrected within  $\pm 20\%$  R.D. of the displayed value at the time of shipment.

### ■ Unit selection function

the pressure unit displayed on the sub screen can be changed.

Display unit	kPa	bar	psi
Minimum setting resolution	0.1	0.001	0.02

### ■ Forced output

The output can be fixed to an ON/OFF state when starting the system or during maintenance. This enables the confirmation of the wiring and prevents system errors due to unexpected output.

### ■ Zero-clear of pressure value

The pressure value displayed on the sub screen can be cleared to zero.

## Series Variations



		ISA3-L	ISA3	
Number of display digits	Main	4	3	
	Sub	9	6	
Output specifications		IO-Link communication/ OUT1 + OUT2	1 output	2 outputs
OUT1	OUT1	<input checked="" type="checkbox"/>	<input checked="" type="checkbox"/>	<input checked="" type="checkbox"/>
	IO-Link communication	<input checked="" type="checkbox"/>	<input type="checkbox"/>	<input type="checkbox"/>
	OUT1 Window comparator mode	<input checked="" type="checkbox"/>	<input type="checkbox"/>	<input type="checkbox"/>
	OUT1 Normal/Reversed output setting	<input checked="" type="checkbox"/>	<input type="checkbox"/>	<input type="checkbox"/>
OUT2	OUT2	<input checked="" type="checkbox"/>	<input type="checkbox"/>	<input checked="" type="checkbox"/>
	OUT2 Window comparator mode	<input checked="" type="checkbox"/>	<input type="checkbox"/>	<input checked="" type="checkbox"/> (Cannot be selected when the output target is distance)
	OUT2 Normal/Reversed output setting	<input checked="" type="checkbox"/>	<input type="checkbox"/>	<input checked="" type="checkbox"/> (Cannot be selected when the output target is distance)
	OUT2 Error output, Output OFF setting	<input checked="" type="checkbox"/>	<input type="checkbox"/>	<input type="checkbox"/>
	OUT2 Delay time setting	<input checked="" type="checkbox"/>	<input type="checkbox"/>	<input checked="" type="checkbox"/> (Selectable)
Setting mode	3-step setting mode	<input checked="" type="checkbox"/> * Depends on the sub screen	<input checked="" type="checkbox"/>	<input checked="" type="checkbox"/>
	Simple setting mode	<input checked="" type="checkbox"/>	<input type="checkbox"/>	<input type="checkbox"/>
	Function selection mode	<input checked="" type="checkbox"/>	<input checked="" type="checkbox"/>	<input checked="" type="checkbox"/>
Function	Display fine adjustment	<input checked="" type="checkbox"/>	<input checked="" type="checkbox"/>	<input checked="" type="checkbox"/>
	Dual display	<input checked="" type="checkbox"/>	<input type="checkbox"/>	<input type="checkbox"/>
	Line name display	<input checked="" type="checkbox"/> Dual display is available.	<input type="checkbox"/>	<input type="checkbox"/>
	Zero cut-off range can be changed.	<input checked="" type="checkbox"/>	<input type="checkbox"/>	<input type="checkbox"/>
	Display OFF function	<input checked="" type="checkbox"/>	<input checked="" type="checkbox"/>	<input checked="" type="checkbox"/>
	Security code	<input checked="" type="checkbox"/>	<input checked="" type="checkbox"/>	<input checked="" type="checkbox"/>
	Setting of all functions	<input checked="" type="checkbox"/>	<input checked="" type="checkbox"/>	<input checked="" type="checkbox"/>
	Pressure zero-clear	<input checked="" type="checkbox"/>	<input checked="" type="checkbox"/>	<input checked="" type="checkbox"/>
	Pressure span adjustment	<input checked="" type="checkbox"/>	<input type="checkbox"/>	<input type="checkbox"/>
	Test output	<input checked="" type="checkbox"/>	<input checked="" type="checkbox"/>	<input checked="" type="checkbox"/>
Initialization	<input checked="" type="checkbox"/>	<input checked="" type="checkbox"/>	<input checked="" type="checkbox"/>	

# 3-Screen Display Digital Gap Checker Without Control Unit

## ISA3-L Series



### How to Order

ISA3 - **G** **C** **L** - **M** **2** **□** **□**

#### Rated distance range

<b>F</b>	0.01 to 0.03 mm
<b>G</b>	0.02 to 0.15 mm
<b>H</b>	0.05 to 0.30 mm

#### Piping specification

	Supply side	Detection side
<b>C</b>	Rc1/8	$\phi 4$ One-touch fitting *1
		$\phi 6$ One-touch fitting *2
<b>F</b>	G1/8 *3	G1/8 *3

- \*1 When F is selected for the rated distance range
- \*2 When G or H is selected for the rated distance range
- \*3 Conforming to ISO 1179-1

#### Output specification

**L** IO-Link: Switch output 1 + Switch output 2 (Switch output: NPN or PNP switching type)

OUT1: Gap size detection  
OUT2: Gap size, outlet pressure, supply pressure detection (Select from the above.)

#### Unit specification of pressure value

<b>Nil</b>	With unit selection function *9
<b>M</b>	Fixed SI unit *10

- \*9 Under the New Measurement Act, digital gap checkers with the unit selection function are no longer allowed for use in Japan.
- \*10 Unit: kPa

#### Stations

<b>1</b>	1 station
<b>2</b>	2 stations
<b>3</b>	3 stations
<b>4</b>	4 stations
<b>5</b>	5 stations
<b>6</b>	6 stations

#### Option 1 (Cable)

<b>Nil</b>	Straight *5 *6	<b>S</b>	Centralized lead wire (Lead wire only) *4 *5
<b>L</b>	Right angle *5 *6		
<b>N</b>	None	<b>T</b>	Centralized lead wire (With bracket) *4 *5
*4 Cannot be selected for 1 station. One set is provided per manifold. A centralized lead wire is provided with M12 connectors for the number of stations. Refer to page 25 for details. *5 At the factory, the options are not attached to the product, but packed together with it for shipment. *6 Cables are provided for the number of stations.			



#### Option 2 (Bracket)

<b>Nil</b>	None (DIN rail mounting) *7
<b>B</b>	With bracket *5 *8

- \*7 Order DIN rail separately. (Refer to page 21.)
- \*8 About the number of brackets, 1 station: 1 piece is packed, 2 stations or more: 2 pieces are packed.

#### Bracket mounting position

**2 stations**  
(Mount to 1st and 2nd stations)



**n stations**  
(Mount to 1st and nth stations)

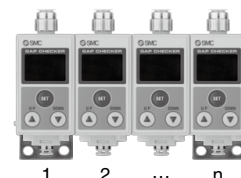

# 3-Screen Display Digital Gap Checker With Control Unit

## ISA3-L Series



### How to Order

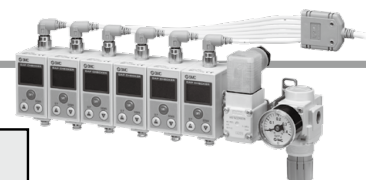

ISA3-GCL-M2 B-L1

#### Rated distance range

<b>F</b>	0.01 to 0.03 mm
<b>G</b>	0.02 to 0.15 mm
<b>H</b>	0.05 to 0.30 mm

#### Piping specification

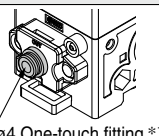
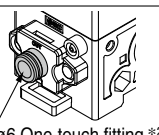
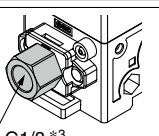
	Supply side	Detection side
<b>C</b>	Rc1/8	 ø4 One-touch fitting *1
		 ø6 One-touch fitting *2
<b>F</b>	G1/8 *3	 G1/8 *3

- \*1 When F is selected for the rated distance range
- \*2 When G or H is selected for the rated distance range
- \*3 Conforming to ISO 1179-1

#### Output specification

**L** IO-Link: Switch output 1 + Switch output 2 (Switch output: NPN or PNP switching type)

OUT1: Gap size detection  
OUT2: Gap size, outlet pressure, supply pressure detection (Select from the above.)

#### Unit specification of pressure value

<b>Nil</b>	With unit selection function *12
<b>M</b>	Fixed SI unit *13

\*12 Under the New Measurement Act, digital gap checkers with the unit selection function are no longer allowed for use in Japan.

\*13 Unit: kPa

#### Stations

<b>1</b>	1 station
<b>2</b>	2 stations
<b>3</b>	3 stations
<b>4</b>	4 stations
<b>5</b>	5 stations
<b>6</b>	6 stations

#### Option 1 (Cable)

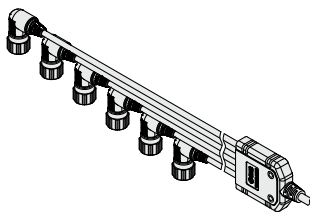
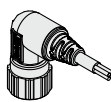
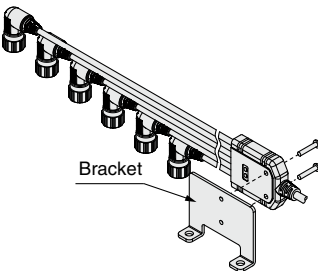
<b>Nil</b>	Straight *5 *6 	<b>S</b>	Centralized lead wire (Lead wire only) *4 *5 
<b>L</b>	Right angle *5 *6 		Centralized lead wire (With bracket) *4 *5 
<b>N</b>	None	<b>T</b>	

- \*4 Cannot be selected for 1 station. One set is provided per manifold. A centralized lead wire is provided with M12 connectors for the number of stations. Refer to page 25 for details.
- \*5 At the factory, the options are not attached to the product, but packed together with it for shipment.
- \*6 Cables are provided for the number of stations.

#### 2-port solenoid valve rated voltage

<b>Nil</b>	24 VDC
<b>1</b> *11	100 VAC
<b>2</b> *11	110 VAC

\*11 Produced upon receipt of order

#### Regulator (Refer to page 22.)

N *10	Without regulator		
<b>0</b> *10	Without pressure gauge		
<b>1</b>	Round type pressure gauge	0.4 MPa	MPa single notation
	Square type pressure gauge		
<b>2</b>	Round type pressure gauge	0.2 MPa	
	Square type pressure gauge		
<b>3</b>	Round type pressure gauge	0.4 MPa	MPa-psi double notation
	Square type pressure gauge		
<b>4</b>	Round type pressure gauge	0.2 MPa	
	Square type pressure gauge		
<b>5</b> *10	Round type pressure gauge	0.4 MPa	psi single notation
	Square type pressure gauge		
<b>6</b> *10	Round type pressure gauge	0.2 MPa	
	Square type pressure gauge		
<b>7</b> *10	Round type pressure gauge	0.4 MPa	MPa-psi double notation
	Square type pressure gauge		
<b>8</b> *10	Round type pressure gauge	0.2 MPa	
	Square type pressure gauge		

\*10 Produced upon receipt of order

#### Control unit (Regulator, 2-port valve)

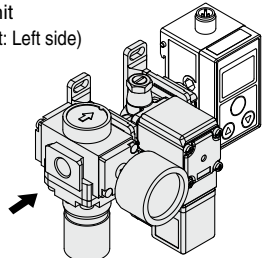
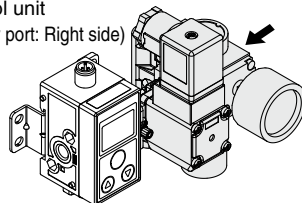
<b>L</b>	Control unit (Supply port: Left side) 
<b>R</b>	Control unit (Supply port: Right side) 

#### Control unit piping specification \*8

Gap checker piping specification	Supply port piping specification
<b>C</b>	Rc1/4
<b>F</b>	G1/4 *9

- \*8 When the control unit is mounted, the piping specifications of the supply port will be changed due to piping specification of the gap checker.
- \*9 Conforming to ISO 16030

#### Option 2 (Bracket)

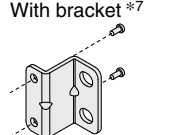
<b>B</b>	With bracket *7 
----------	--

\*7 The bracket for control unit is shipped mounted on the product.

# ISA3-L Series

For gap checker precautions and specific product precautions, refer to the "Operation Manual" on the SMC website. Click [here](#) for details.

## Specifications

Model		ISA3-FL	ISA3-GL	ISA3-HL
Applicable fluid		Dry air (Filtered through a 5 μm filter)		
OUT1 OUT2 *6	Rated distance range	0.01 to 0.03 mm	0.02 to 0.15 mm	0.05 to 0.30 mm
	Displayable/Settable range (Distance reference) *1	0 to 60 *2	0 to 300 *2 *3	0 to 500 *2 *4
	Minimum display resolution (Distance reference) *1	1		
	Rated pressure range	100.0 to 200.0 kPa		
	Displayable range (Pressure value) *5	-20.0 to 220.0 kPa		
	Repeatability	0.005 mm or less	0.010 mm or less	0.020 mm or less
	Temperature characteristics (Reference: 25°C)	0.010 mm or less	0.015 mm or less	0.030 mm or less
Hysteresis	0 to variable (Default: 3)	0 to variable (Default: 20)		
OUT2 *7	Rated pressure range	0.0 to 200.0 kPa		
	Set pressure range	-20.0 to 220.0 kPa		
	Minimum display/setting resolution	0.1 kPa		
	Repeatability	±0.5% F.S. ±1 digit		
	Temperature characteristics (Reference: 25°C)	±2% F.S.		
Hysteresis	0 to variable *8			
Withstand pressure	600 kPa			
Detection nozzle	ø1.5 *9			
Consumption flow rate	5 L/min or less	12 L/min or less	22 L/min or less	
Electrical	Power supply voltage	24 VDC ±10% with 10% voltage ripple or less		
	When used as a switch output device	18 to 30 VDC, including ripple (p-p) 10%		
	When used as an IO-Link device	25 mA or less		
Current consumption	Power supply polarity protection			
Protection	Select from NPN or PNP open collector output.			
Switch output	Select from NPN or PNP open collector output.			
Maximum load current	10 mA			
	Maximum applied voltage	30.0 V		
	Residual voltage	1 V or less (at 10 mA)		
	Short-circuit protection	Provided		
Display	2-screen display (3 types of display are available: Sub screen: 4-digit x 2) Main screen: 4-digit 7-segment, 2-color (Orange/Green) Sub screen: 9-digit (Upper 9-digit, 4-digit, 3-digit 11-segment, 7-segment for other)			
Environmental resistance	Enclosure	IP67 equivalent *10		
	Operating temperature range	Operating: 0 to 50°C, Stored: -20 to 70°C (No condensation or freezing)		
	Operating humidity range	Operating/stored: 35 to 85% RH (No condensation)		
	Withstand voltage	1000 VAC or more (in 50/60 Hz) for 1 minute between terminals and housing		
Insulation resistance	2 MΩ or more (500 VDC measured via megohmmeter) between terminals and housing			
Piping	For C type	Supply port	Rc1/8	
		Detection port	ø4 One-touch fitting	ø6 One-touch fitting
	For F type	Supply port	G1/8 (Conforming to ISO 1179-1)	
		Detection port	G1/8 (Conforming to ISO 1179-1)	
Cable	Lead wire with connector	M12 lead wire with 4 pin connector, 4 cores, ø4, 5 m Conductor O.D.: 0.72 mm, Insulator O.D.: 1.14 mm		
	Centralized lead wire	M12 lead wire with 4 pin connector part, 4 cores, ø4, Insulator O.D.: 1.14 mm Centralized lead wire part, 2 to 3 stations: 8 cores, ø6, 5 m, 4 to 6 stations: 14 cores, ø6, 5 m Conductor O.D.: 0.50 mm, Insulator O.D.: 1.00 mm (2 to 6 stations common)		
Weight	113 g (Cable not included, One-touch fitting)			
Standards	CE marking (EMC Directive, RoHS Directive)			
Communication (IO-Link mode)	IO-Link type	Device		
	IO-Link version	V1.1		
	Communication speed	COM2 (38.4 kbps)		
	Configuration file	IODD file *11		
	Minimum cycle time	4.2 ms		
	Process data length	Input data: 8 bytes, Output data: 0 bytes		
	On request data communication	Yes		
	Data storage function	Yes		
Event function	Yes			
Vendor ID	131 (0 x 0083)			

- \*1 For details, refer to the Relationship Between Displayed Value and Distance on page 18.
- \*2 If hysteresis is set to 3 (Default setting), the "Displayable/Settable range" of the F type is limited to 57. If hysteresis is set to 20 (Default setting), the G type is limited to 280 and the H type is limited to 480. (Reversed output: Factory default value)
- \*3 Due to the zero-cut function, the values of 8 and under are displayed as 0 at factory default setting.
- \*4 Due to the zero-cut function, the values of 29 and under are displayed as 0 at factory default setting.
- \*5 The pressure value will be the indicated on the sub screen.
- \*6 Refers to when OUT2 is set to detect the distance

- \*7 Refers to when OUT2 is set to detect the pressure
- \*8 If the applied pressure fluctuates around the set value, the hysteresis must be set to a value more than the fluctuating width, otherwise chattering will occur.
- \*9 For details on the detection nozzle, refer to the figures on page 18.
- \*10 Only applies to the digital gap checker body excluding the control unit.
- \*11 The configuration file can be downloaded from the SMC website, <https://www.smcworld.com>
- \* Products with tiny scratches, marks, or display color or brightness variations which do not affect the performance of the product are verified as conforming products.

### Rated Distance Range and Displayable/Settable Range

**⚠ Caution** The displayed value is a reference value obtained by converting the distance between the workpiece and the detection surface into a digital numerical value. It is not displayed in units. For details, refer to the Relationship Between Displayed Value and Distance on page 18.  
 Rated distance range: Distance range within which the product meets the specifications  
 Displayable/Settable range: Range within which it is possible to display or set values, (Not guaranteed to meet the specifications)

Model	Distance				
	0 mm	0.02 mm	0.05 mm	0.15 mm	0.30 mm
ISA3-F type	[Bar chart showing ranges for ISA3-F type]				
ISA3-G type	[Bar chart showing ranges for ISA3-G type]				
ISA3-H type	[Bar chart showing ranges for ISA3-H type]				

■ Rated distance range    ▒ Displayable/Settable range    ⋯ When zero cut-off is minimum



### Supply Pressure Dependence Characteristics

The distance for the product to turn ON varies depending on the supply pressure.

The graphs below show the variation of the distance for the product to turn ON, for 3 types of gap, by changing the supply pressure ( $\pm 50$  kPa) when the product is set to turn ON at 150 kPa supply pressure.

<b>Test conditions</b>	<b>Detection nozzle:</b> $\phi 1.5$ <b>Piping:</b> F type $\phi 4 \times \phi 2.5$ tube/G, H type $\phi 6 \times \phi 4$ tube <b>Reference pressure:</b> 150 kPa
------------------------	---

\* Use within the rated pressure range (100 kPa to 200 kPa).

It will be impossible to measure the gap when the operating pressure is less than 80 kPa or over 220 kPa. And the output will be OFF. (Refer to the Relationship Between Supply Pressure and Display on page 26.)

#### ISA3-FL

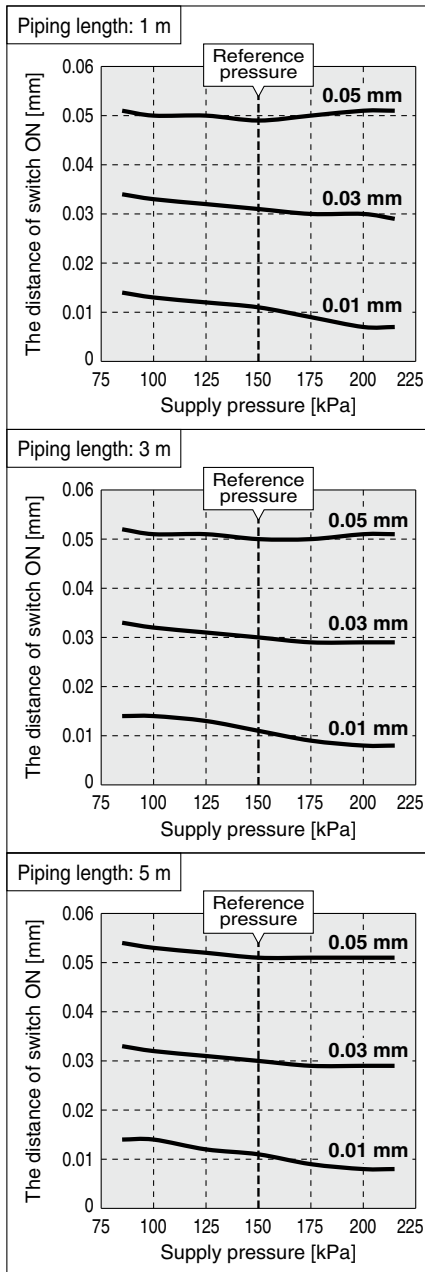

#### ISA3-GL

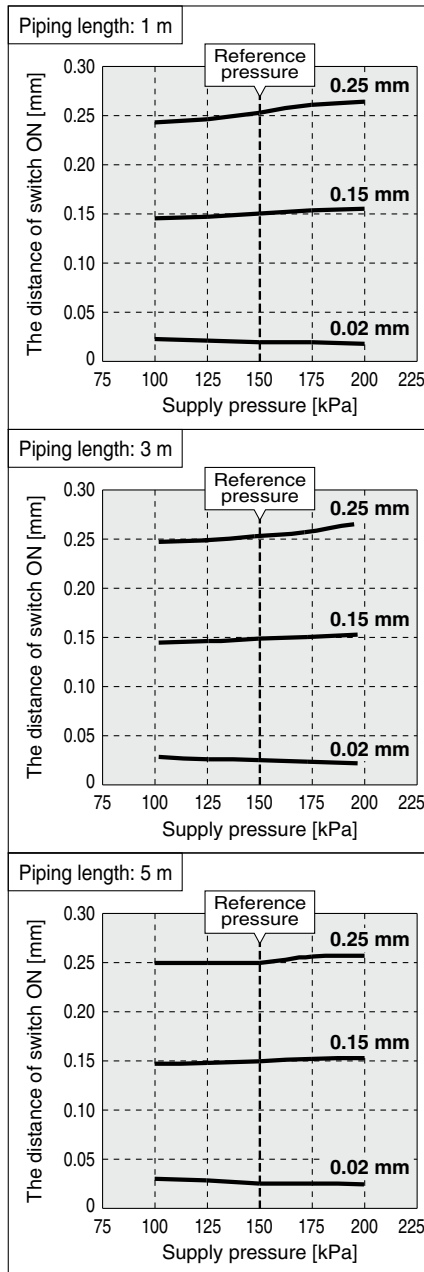

#### ISA3-HL

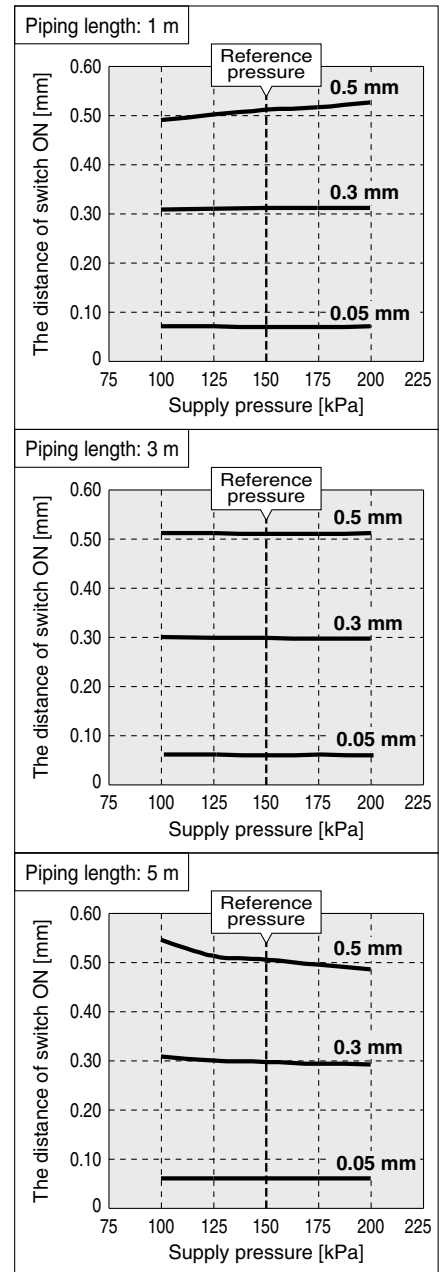

# ISA3-L Series

## Response Time

Response time is the elapsed time between the pressure supply and the turning ON of the switch output.

The response time varies depending on the piping length from the OUT port to the detection nozzle, and the seating condition of the workpiece. The graphs below show the response time when the workpiece is approached at 90% distance and 0% distance (close contact). (\* The switch point is 100% distance.)

(Example: When the switch point is set to 0.1 mm, the response time when the workpiece is at 0.09 mm and 0 mm are measured.)

<b>Test conditions</b>	<b>Detection nozzle:</b> $\phi 1.5$ <b>Piping:</b> F type $\phi 4 \times \phi 2.5$ tube/G, H type $\phi 6 \times \phi 4$ tube <b>Supply pressure:</b> 200 kPa
------------------------	--

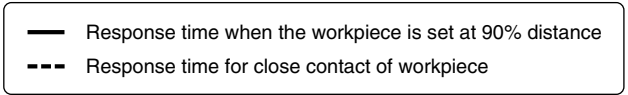

### ISA3-FL

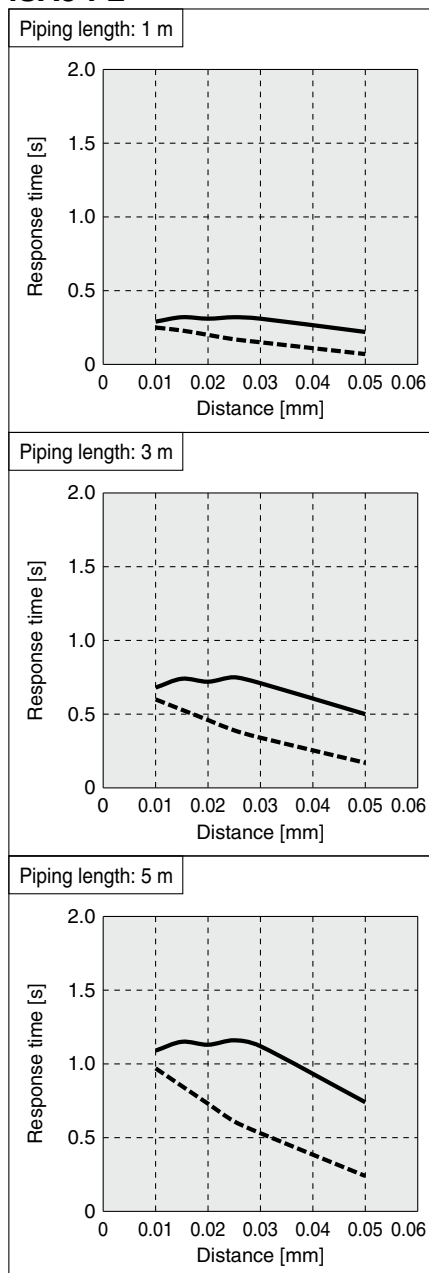

### ISA3-GL

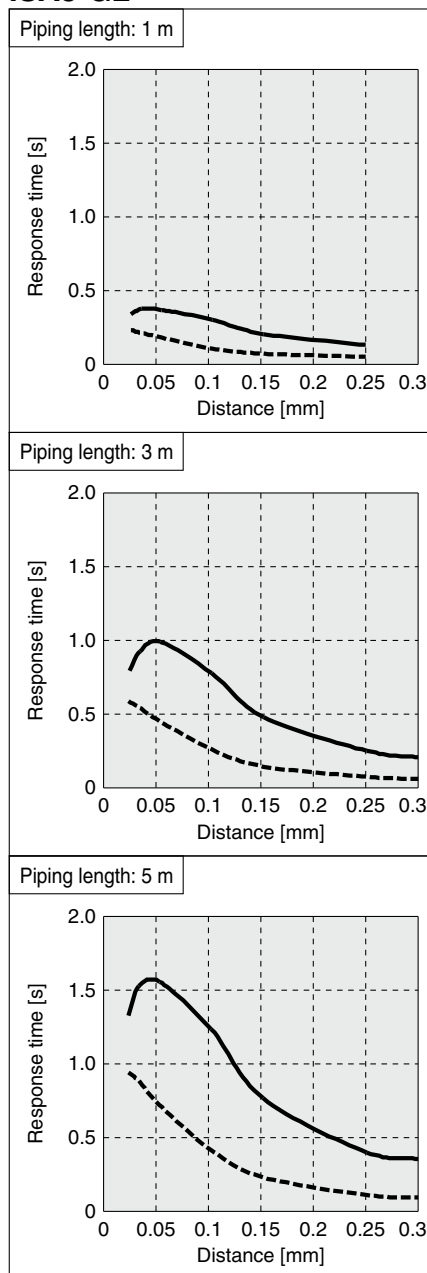

### ISA3-HL

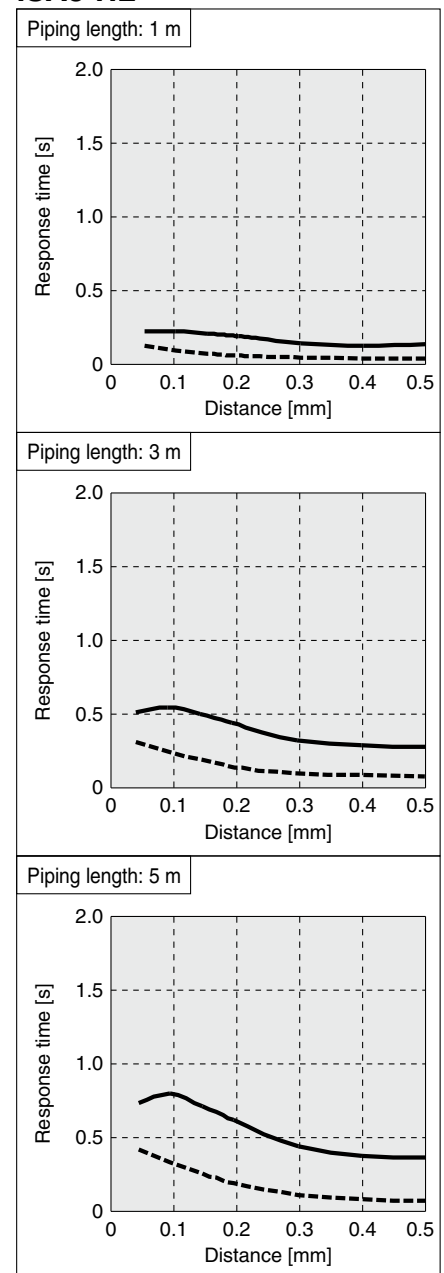

### Relationship Between Displayed Value and Distance

The graphs below show the relationship between the displayed value and distance.

1. The data shown below are for reference. They change depending on the individual product differences and machining dimensions of the nozzle.
2. The zero-cut function forcibly displays 0 when the value is less than the set value. Although the zero cut-off range can be set to 0, it may not be 0 even in close contact, due to the characteristics of the product.

Test conditions	Detection nozzle: $\phi 1.5$
	Detection nozzle piping: F type $\phi 4 \times \phi 2.5$ tube 1 m, 3 m, 5 m/ G, H type $\phi 6 \times \phi 4$ tube 1 m, 3 m, 5 m
	Supply pressure: 200 kPa

#### ISA3-FL

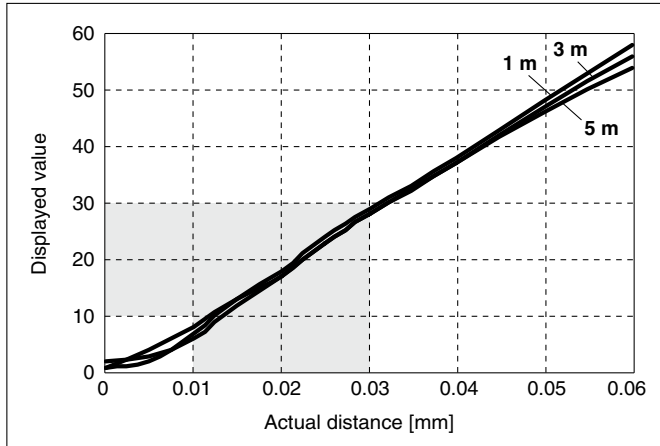

#### ISA3-GL

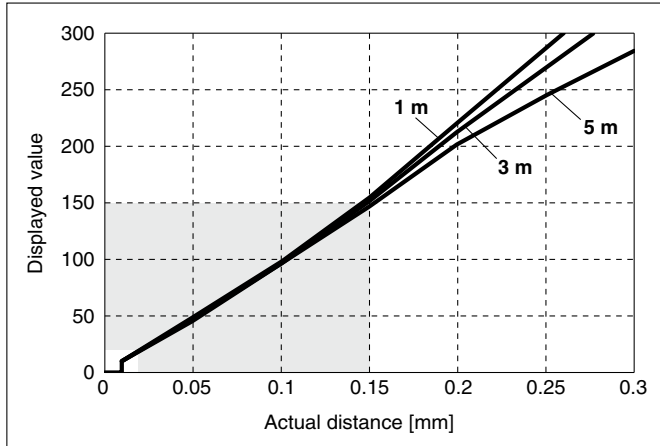

\* Default setting: Values of 8 and under are displayed as "0."

#### ISA3-HL

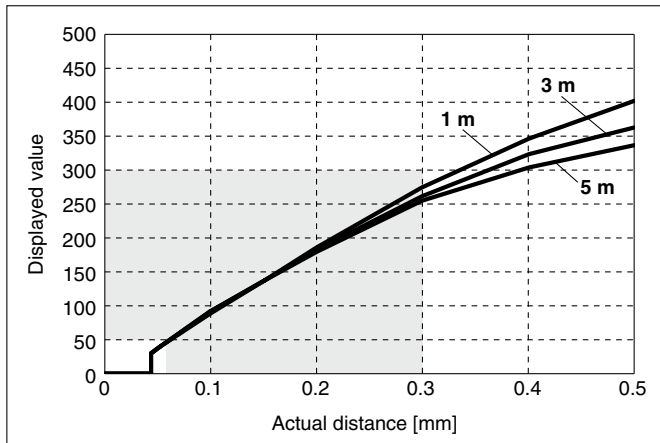

\* Default setting: Values of 29 and under are displayed as "0."

### Detection Nozzle Shape

The nozzle shape must be similar to Fig. 1.

Do not chamfer the nozzle as shown in Fig. 2, as the characteristics will be affected.

Fig. 1: Recommended nozzle shape

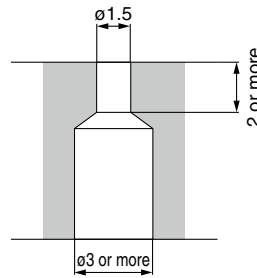
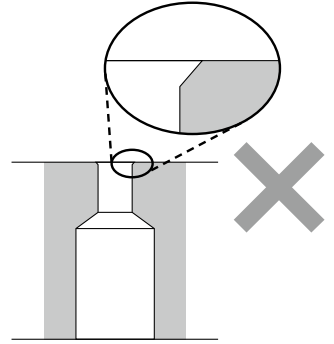

Fig. 2: Unsuitable nozzle shape



### Internal Circuits and Wiring Examples

#### When used as a switch output device

\* The numbers in the circuit diagrams show the connector pin layout.

##### Setting of NPN open collector 2 outputs

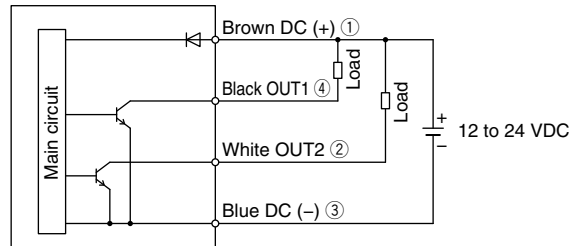

##### Setting of PNP open collector 2 outputs

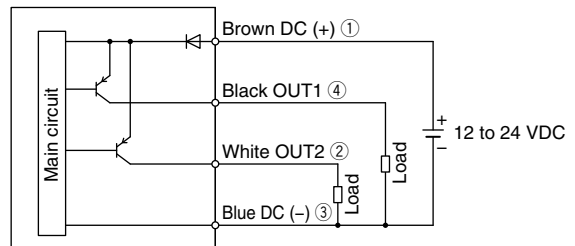

#### When used as an IO-Link device

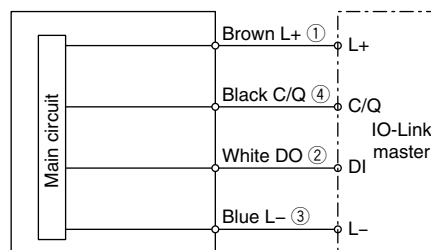

\* Refer to the **Web Catalog** for wiring details of the VX2 series (2-port solenoid valve).

# ISA3-L Series

## Construction Diagram

### Without control unit

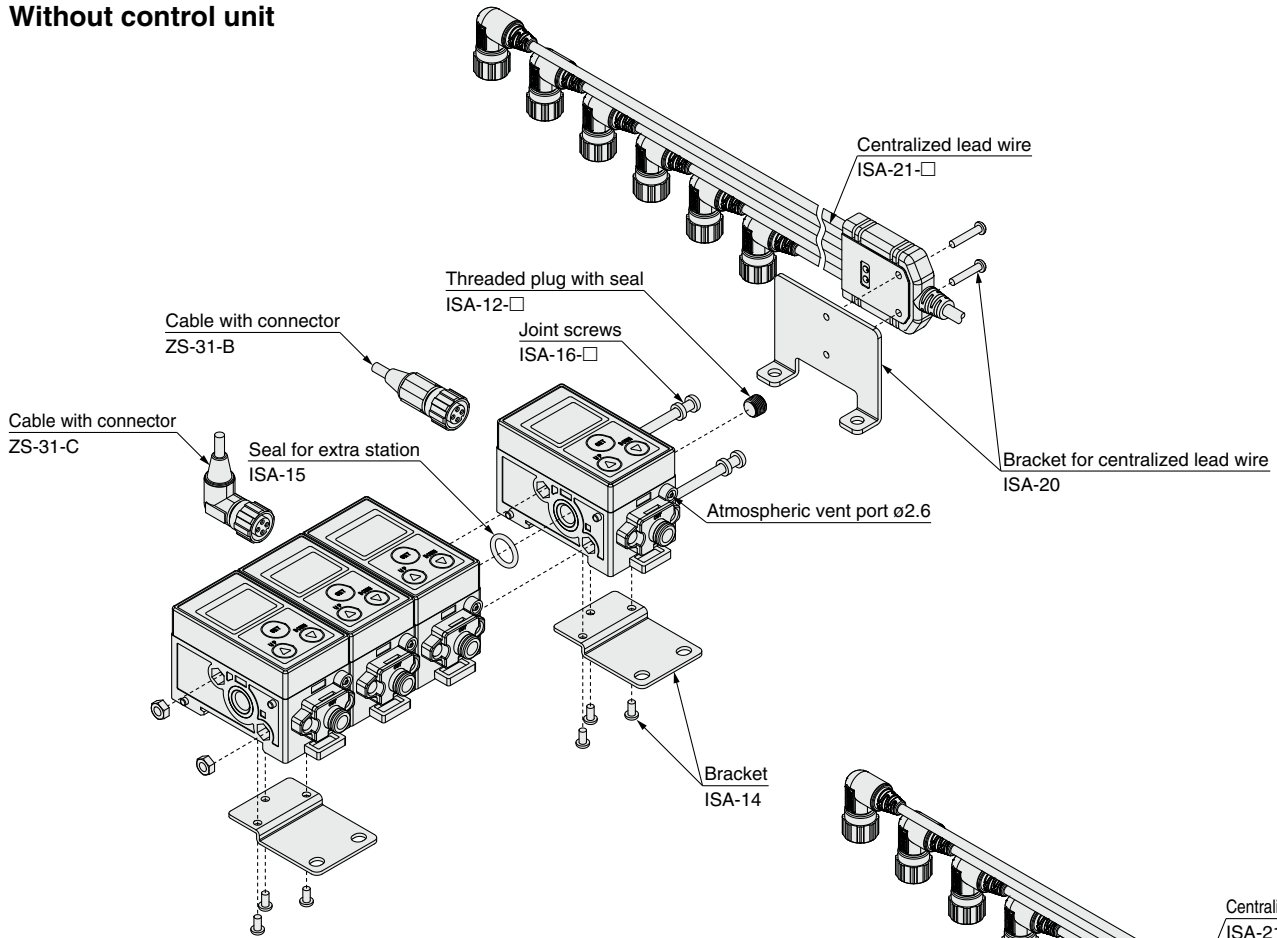

### With control unit Supply port: Left side

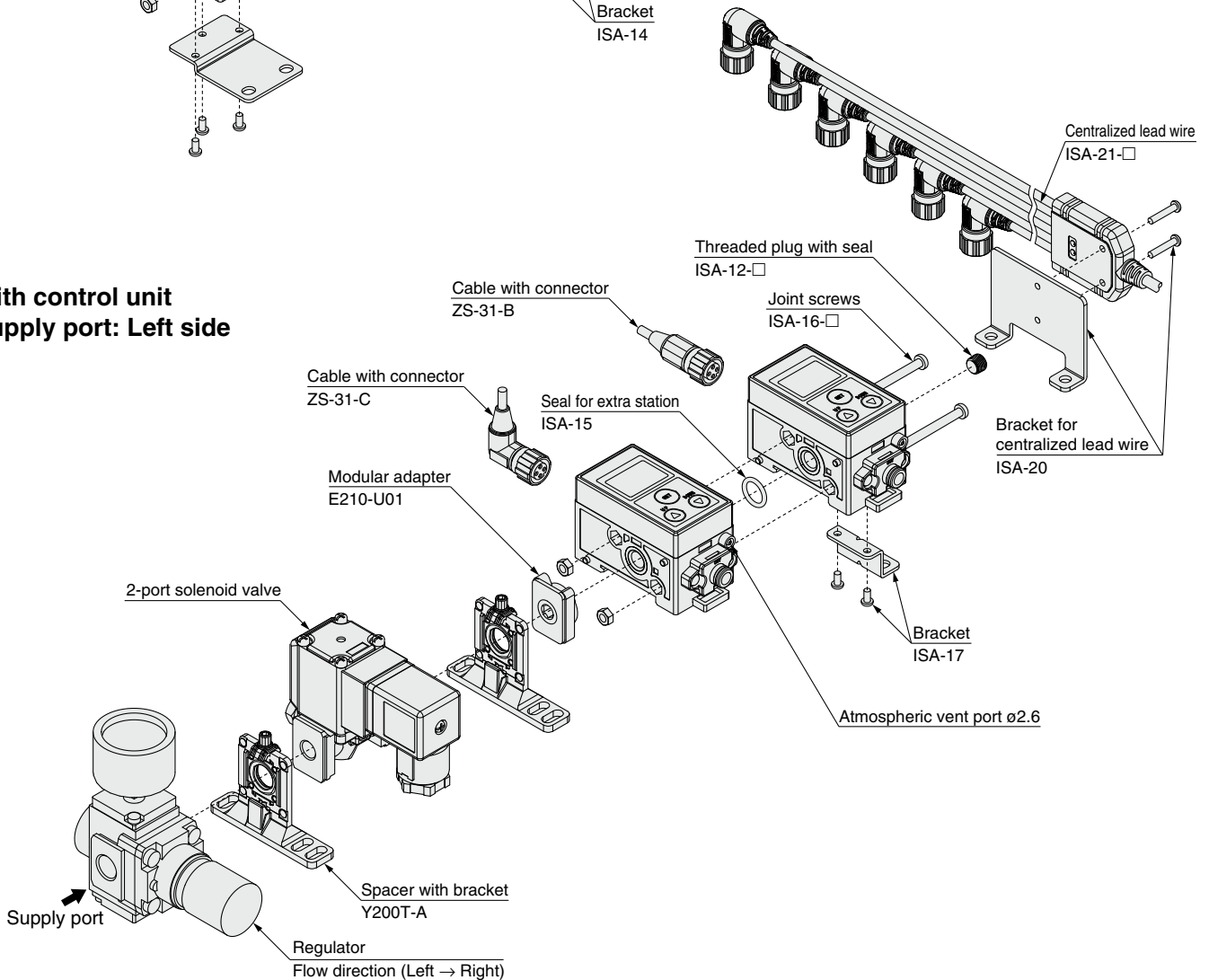

## Construction Diagram

With control unit  
Supply port: Right side

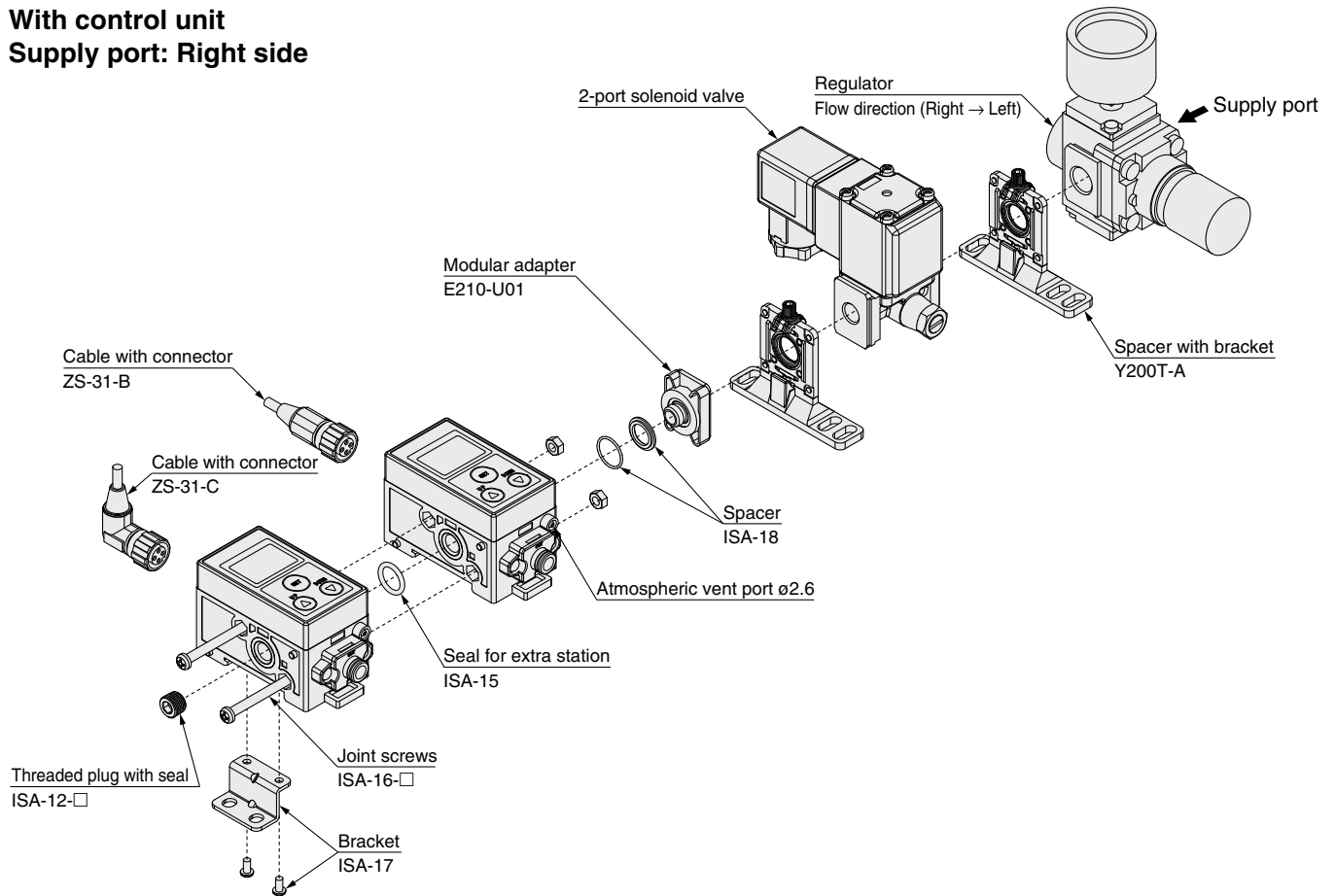

If there is a possibility that the atmospheric vent port of the gap checker will be exposed to water or dust, insert a tube into the atmospheric vent port and route the other end of the tube to a safe place away from water or dust.

\* For tubing, please use the SMC TU0425 (polyurethane, O.D. ø4, I.D. ø2.5) for the gap checker.

### ⚠ Caution

**SMC products are not intended for use as instruments for legal metrology.**

Measurement instruments that SMC manufactures or sells have not been qualified by type approval tests relevant to the metrology (measurement) laws of each country. Therefore, SMC products cannot be used for business or certification ordained by the metrology (measurement) laws of each country.

# ISA3-L Series

## Parts List

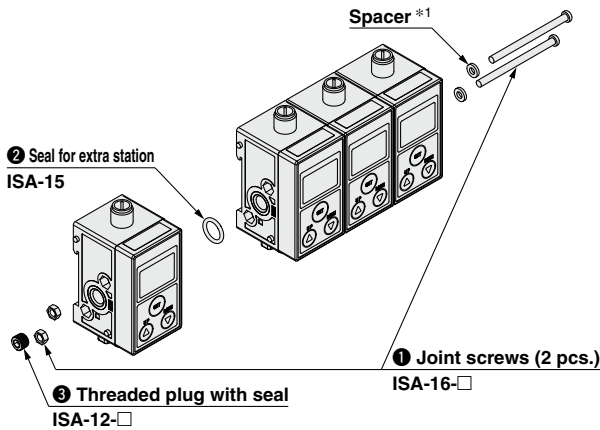

\*1 Spacers are included for 4 and 6 stations.

- 1 Joint screws**  
2 screws,  
2 spacers, 2 nuts

Stations	Part no.
2	ISA-16-2
3	ISA-16-3
4 *1	ISA-16-4
5	ISA-16-5
6 *1	ISA-16-6

- 2 Seal for extra station**  
ISA-15 1 pc.



- 3 Threaded plug with seal**  
ISA-12-□ 1 pc.

Piping	Part no.
Rc1/8	ISA-12-A
G1/8	ISA-12-C



### Bracket ISA-14

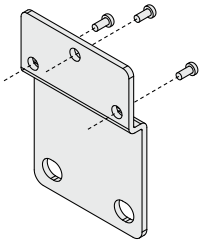

With 3 tapping screws (3 x 8)

### DIN rail ISA-5-1

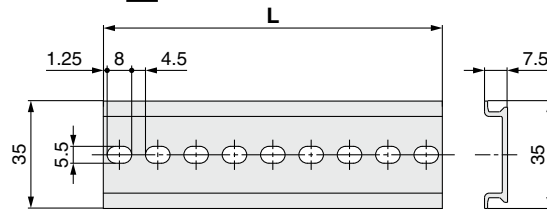

Stations	Part no.	L
1	ISA-5-1	73.0
2	ISA-5-2	135.5
3	ISA-5-3	173.0
4	ISA-5-4	210.5
5	ISA-5-5	248.0
6	ISA-5-6	285.5

### Lead wire with connector ZS-31-B      ZS-31-C

Straight 5 m

Right angle 5 m

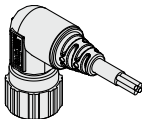

### Centralized lead wire ISA-21-2

Stations	Part no.	L
2	ISA-21-2	139
3	ISA-21-3	177
4	ISA-21-4	215
5	ISA-21-5	253
6	ISA-21-6	291

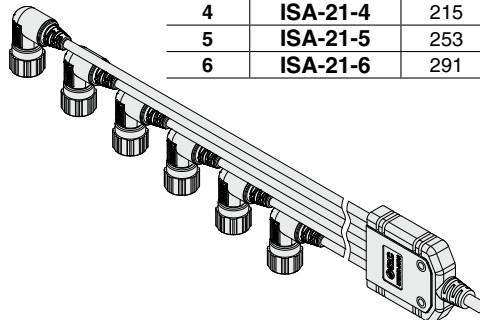

### Bracket for centralized lead wire ISA-20

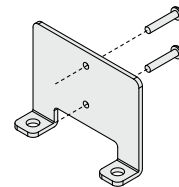

\* With 2 mounting screws (M3 x 16L)

**Parts List (Control Unit)**

■ **Regulator**

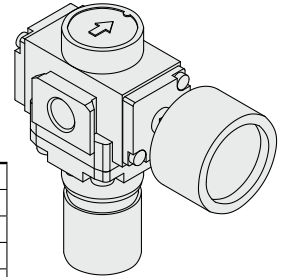
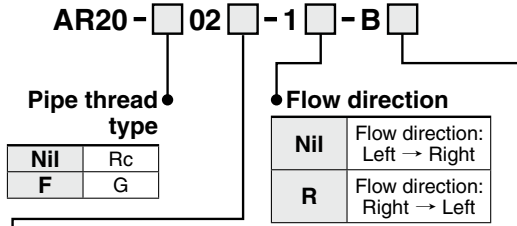

● **Option (Pressure gauge shape)**

Nil	Without pressure gauge
E	With square embedded type pressure gauge (With limit indicator)
G*1	With round type pressure gauge (With limit indicator, MPa single notation)
P*1	With round type pressure gauge (With limit indicator, MPa-psi double notation*2)

● **Max. display pressure of the pressure gauge**

Nil	—
Nil	Max. display pressure: 0.4 MPa, MPa single notation
-X2105	Max. display pressure: 0.2 MPa, MPa single notation
-X2176	Max. display pressure: 60 psi (0.4 MPa), psi single notation*2
-X2175	Max. display pressure: 30 psi (0.2 MPa), psi single notation*2
Nil	Max. display pressure: 0.4 MPa
-X2105	Max. display pressure: 0.2 MPa
Nil	Max. display pressure: 0.4 MPa
-X2105	Max. display pressure: 0.2 MPa

\*1 The pressure gauge port is 1/8. The pressure gauge is included in the package, but not assembled.  
 \*2 This product is for overseas use only according to the New Measurement Act. (The SI unit type is provided for use in Japan.)

For details, refer to the **Web Catalog**.

■ **2-port solenoid valve**

VX210  Z  Z2A  X276

● **Body material/Port size/Orifice diameter**

Symbol	Body material	Port size	Orifice diameter
Z	Aluminum	No thread machining (1/8)	ø4
B*1		Rc1/4	
D*1		G1/4	

● **Specification**

Symbol	Specification
X276	With restrictor

● **Voltage/Electrical entry**

Symbol	Voltage	Electrical entry
Z2A	24 VDC	DIN terminal with light (With surge voltage suppressor)
Z2B*2	100 VAC	
Z2C*2	110 VAC	

● **Restrictor needle**

\*1 Produced upon receipt of order  
 \*2 Produced upon receipt of order  
 When 100 VAC and 110 VAC are selected, the product without thread machining (symbol: Z) cannot be selected.

For specifications other than X276, refer to the **Web Catalog**.

■ **Bracket (when control unit fitted) ISA-17**

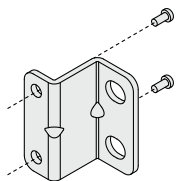

With 2 tapping screws (3 x 8)

■ **Spacer with bracket Y200T-A**

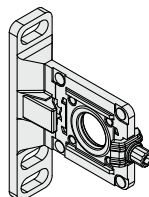

■ **Modular adapter E210-U01**

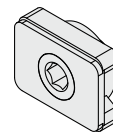

■ **Spacer ISA-18**



\* When a 2-port solenoid valve is connected to the right

# ISA3-L Series

## Dimensions

### ISA3-□□L-□□□□B (Bracket mounting)

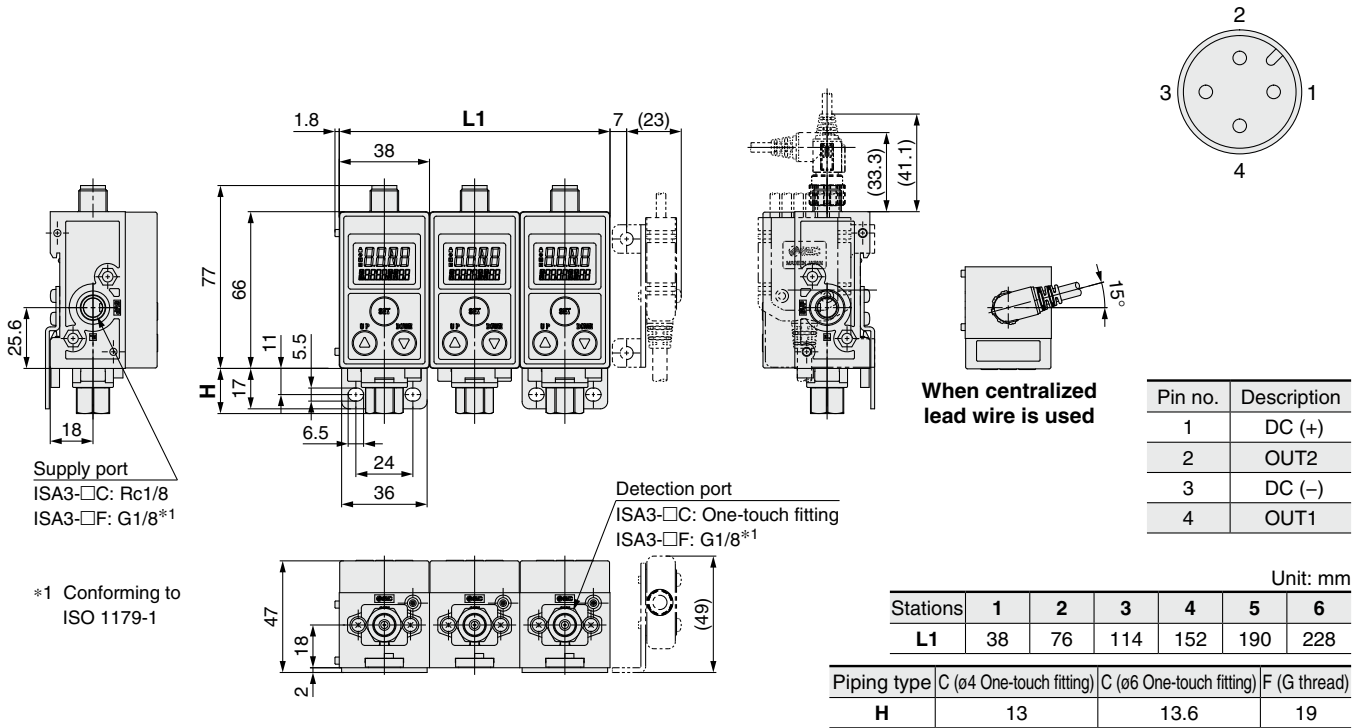

### ISA3-□□L-□□□□ (DIN rail mounting)

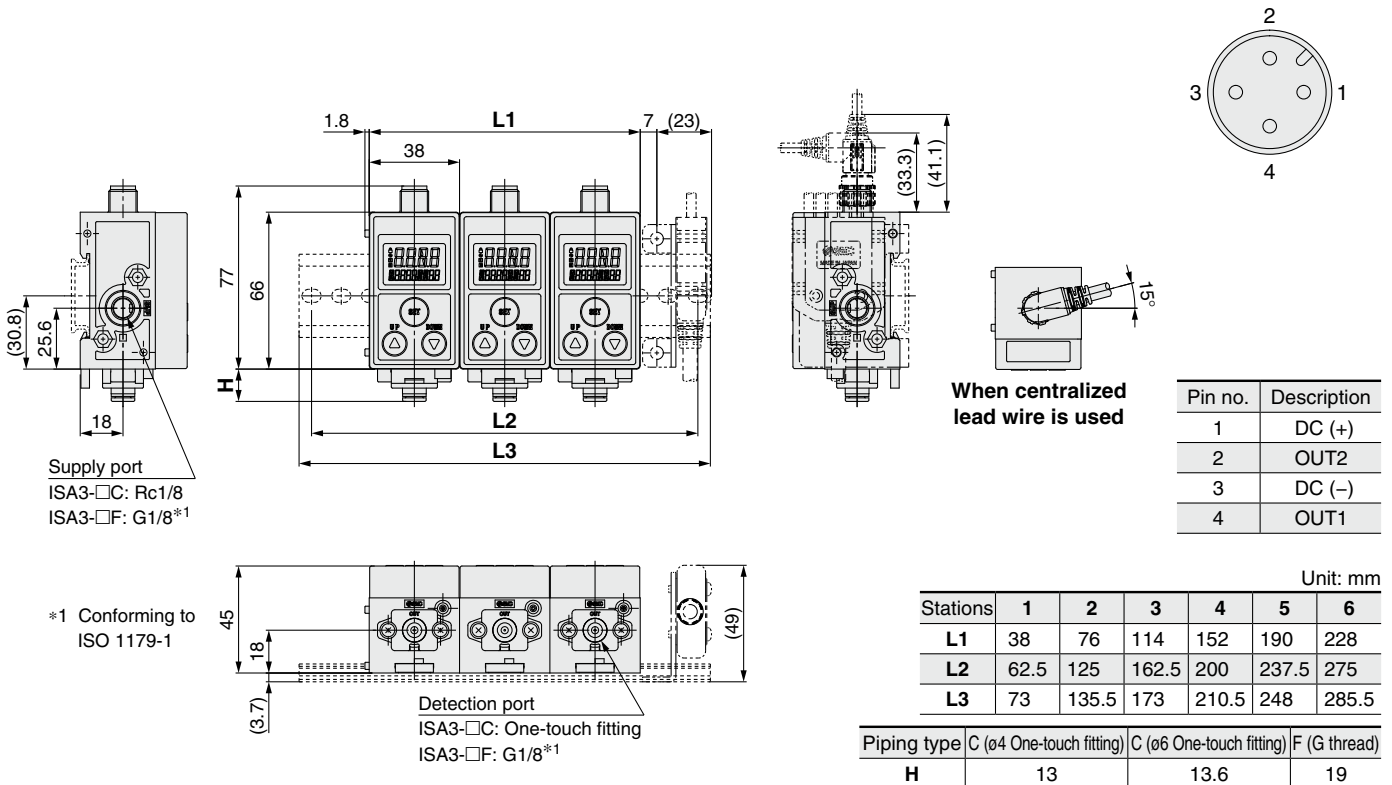



## Dimensions

### ISA3-□□L-□□□B-L □ (With control unit)

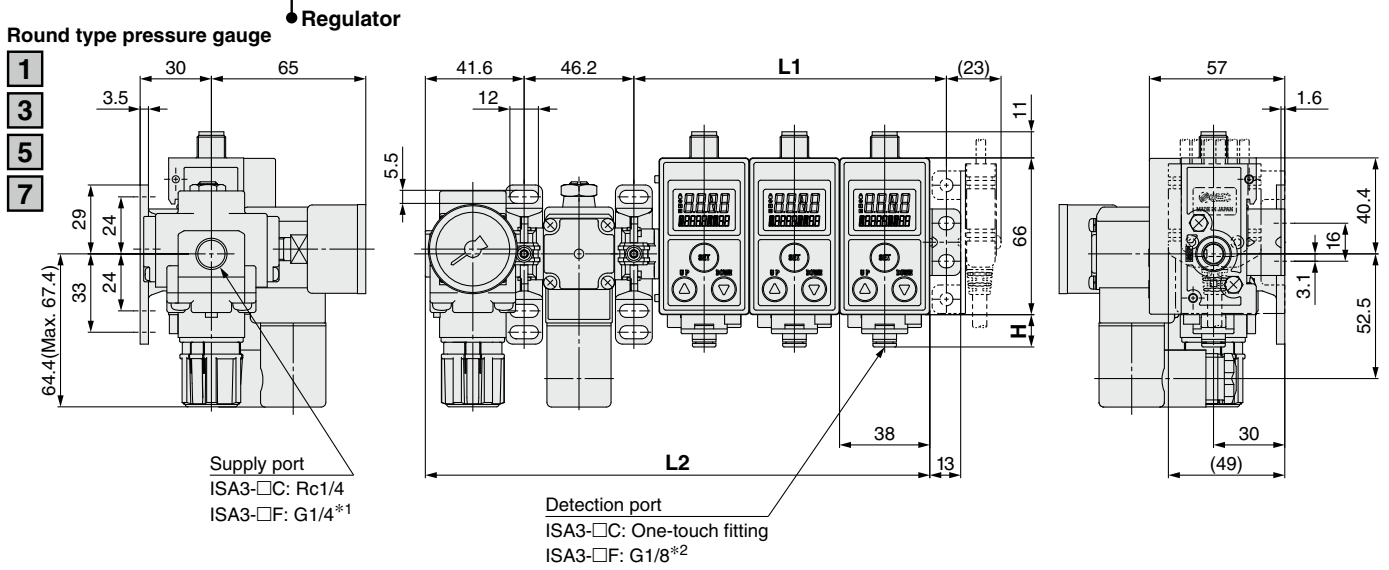

### ISA3-□□L-□□□B-R □

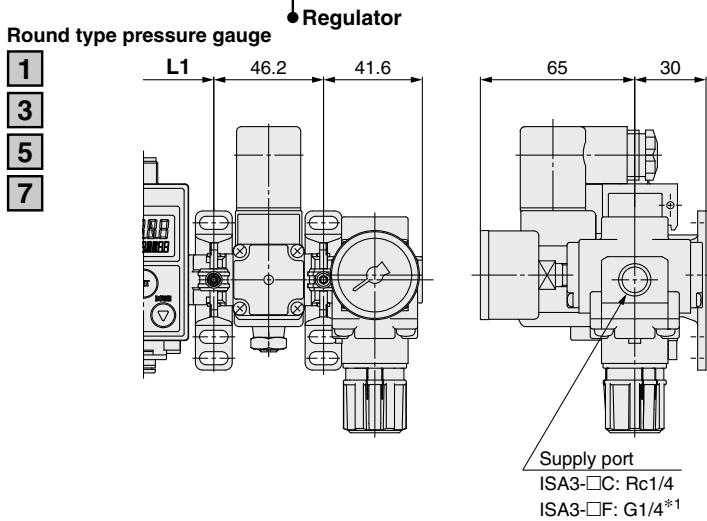

### ISA3-□□L-□□□B-R □

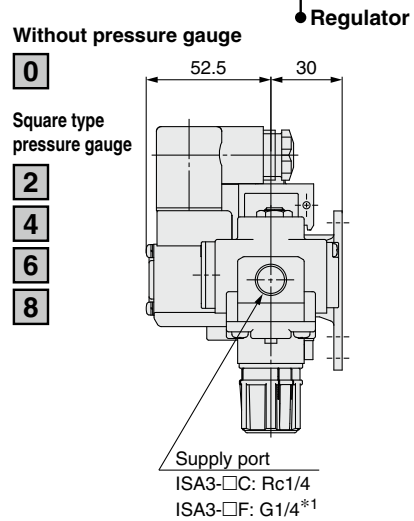

### ISA3-□□L-□□□B-LN □

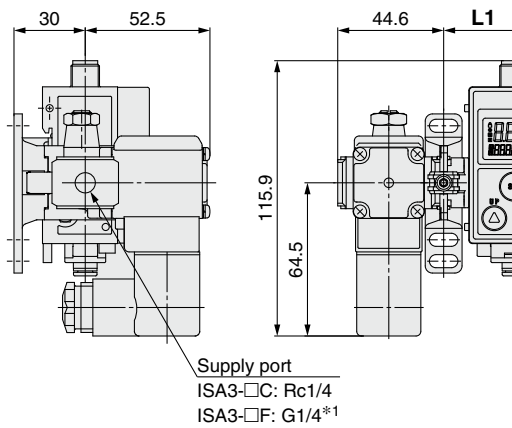

### ISA3-□□L-□□□B-RN □

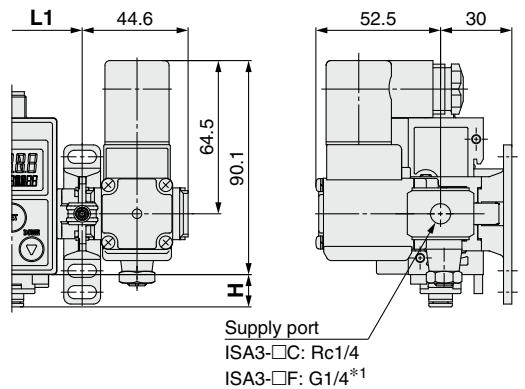

\*1 Conforming to ISO 16030  
\*2 Conforming to ISO 1179-1  
\* Bracket mounting only

Unit: mm

Stations	1	2	3	4	5	6
L1	55.6	93.6	131.6	169.6	207.6	245.6
L2	136.4	174.4	212.4	250.4	288.4	326.4
Piping type	C (ø4 One-touch fitting)		C (ø6 One-touch fitting)		F (G thread)	
H	13		13.6		19	

# ISA3-L Series

## Dimensions

### ZS-31-B (Cable with connector)

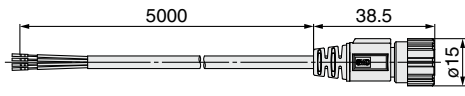

### Connector pin no.

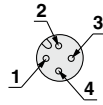

### ZS-31-C (Cable with connector)

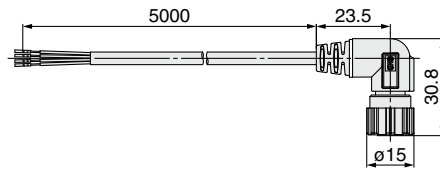

Pin no.	Lead wire color	Description	Pin no.	Lead wire color	Description
1	Brown	DC(+)	3	Blue	DC(-)
2	White	OUT2	4	Black	OUT1

### ISA-21-□ (Centralized lead wire)

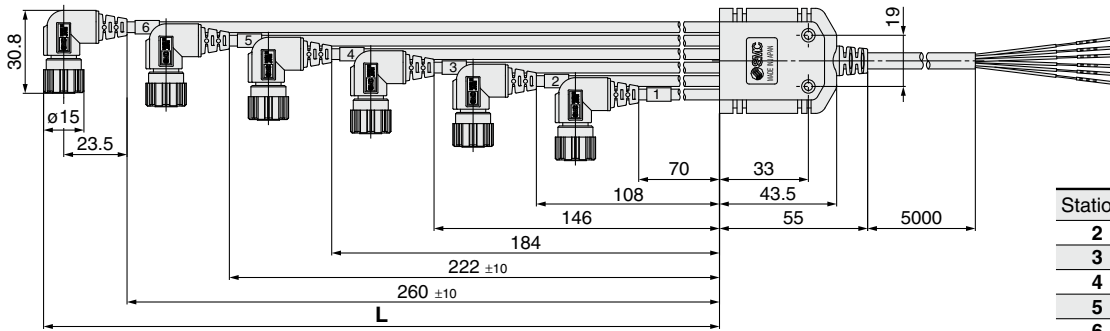

Unit: mm

Stations	Part no.	L
2	ISA-21-2	139
3	ISA-21-3	177
4	ISA-21-4	215
5	ISA-21-5	253
6	ISA-21-6	291

#### For 2 to 3 Stations

M12 connector no.	Pin no.	Description	Output lead wire color
1	1	DC(+)	Brown*1
	2	OUT2	Orange
	3	DC(-)	Blue*1
	4	OUT1	Black
2	1	DC(+)	Brown*1
	2	OUT2	Red
	3	DC(-)	Blue*1
	4	OUT1	White
3	1	DC(+)	Brown*1
	2	OUT2	Green
	3	DC(-)	Blue*1
	4	OUT1	Gray

#### For 4 to 6 Stations

M12 connector no.	Pin no.	Description	Output lead wire color
1	1	DC(+)	Brown*1
	2	OUT2	Yellow
	3	DC(-)	Blue*1
	4	OUT1	Black
2	1	DC(+)	Brown*1
	2	OUT2	Purple
	3	DC(-)	Blue*1
	4	OUT1	White
3	1	DC(+)	Brown*1
	2	OUT2	Gray/Black
	3	DC(-)	Blue*1
	4	OUT1	Gray

M12 connector no.	Pin no.	Description	Output lead wire color
4	1	DC(+)	Brown*1
	2	OUT2	Orange/Black
	3	DC(-)	Blue*1
	4	OUT1	Orange
5	1	DC(+)	Brown*1
	2	OUT2	Red/Black
	3	DC(-)	Blue*1
	4	OUT1	Red
6	1	DC(+)	Brown*1
	2	OUT2	Green/Black
	3	DC(-)	Blue*1
	4	OUT1	Green

\*1 Brown and blue are connected inside the product.

### ISA-14 (Bracket when control unit not fitted)

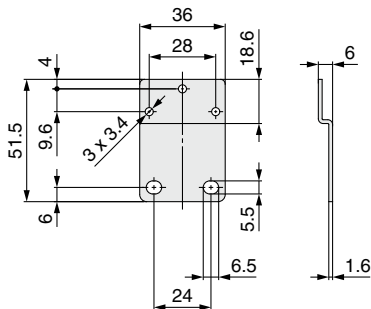

### Y200T-A (Spacer with bracket)

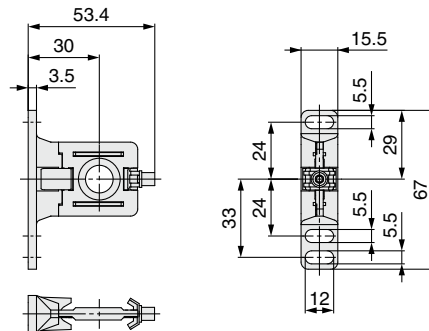

### ISA-17 (Bracket when control unit fitted)

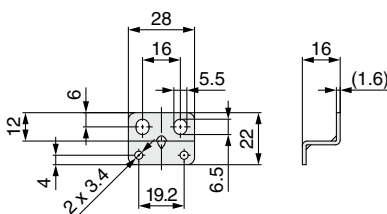

### ISA-20 (Bracket for centralized lead wire)

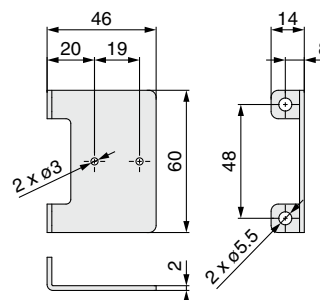

**Error Indication**

Main screen	Name	Description	Measures
- - - -	Supply pressure error	Displayed when supply pressure is outside the range of 80 kPa to 220 kPa. Measurement is not possible.	Supply rated pressure (100 kPa to 200 kPa). The product will return to measurement mode automatically.
- - - -	Outside of the displayable range (Switch point change mode)	The workpiece is outside the displayable range.	Move the workpiece closer to the detection nozzle.
Er 1 oC1	OUT1 over current error	The switch output (OUT1) load current of 80 mA or more flows.	Turn the power OFF and remove the cause of the over current. Then turn the power ON again.
Er 2 oC2	OUT2 over current error	The switch output (OUT2) load current of 80 mA or more flows.	Turn the power OFF and remove the cause of the over current. Then turn the power ON again.
Er 3 ZEro	Zero clear error	Zero clear was not performed at atmospheric pressure. (Pressure outside of ±14 kPa was supplied present.)	Perform zero clear at atmospheric pressure.
Er 30 FSC2	Pressure adjustment error during calibration	Fine adjustment of the pressure display at the OUT port was not performed correctly during calibration. (When the pressure after the adjustment is below the supply pressure lower limit (80 kPa) or exceeds the display set range upper limit (220 kPa))	Keep the SUP port pressure and OUT port pressure the same and perform fine adjustment of the OUT port pressure display value. Set the pressure within 80 kPa to 220 kPa.
Er 0 to Er 9 Er 40	System error	An internal data error has occurred.	Turn the power OFF and turn it ON again.
Er 15 V10	Version does not match	IO-Link version does not match that of the master. The master uses version 1.0.	Ensure that the master IO-Link version matches the device version.
Sub screen	Name	Description	Measures
HHH	Supply pressure error (When [SUP side pressure value display] is set to the sub screen)	Pressure exceeding 220 kPa is supplied.	Keep the supply pressure within the displayable range of -20 kPa to 220 kPa.
LLL		Vacuum pressure (less than -20 kPa) is supplied.	

**Relationship Between Supply Pressure and Display**

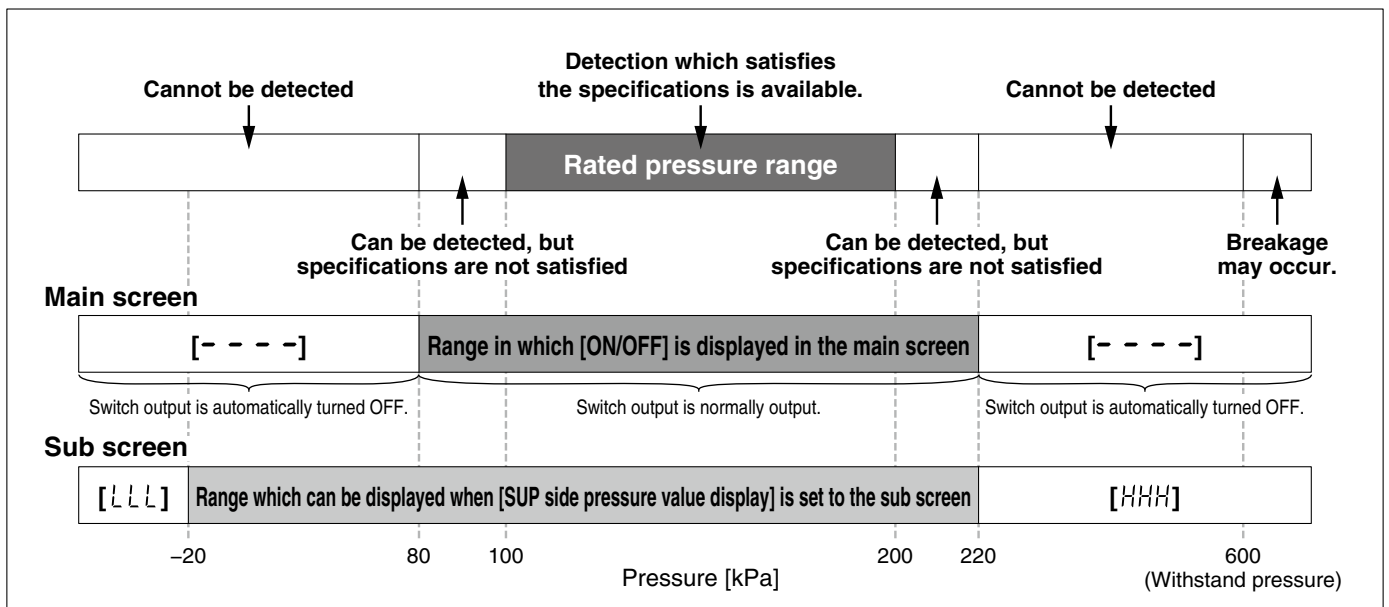

## Safety Instructions

These safety instructions are intended to prevent hazardous situations and/or equipment damage. These instructions indicate the level of potential hazard with the labels of “**Caution**,” “**Warning**” or “**Danger**.” They are all important notes for safety and must be followed in addition to International Standards (ISO/IEC)\*1), and other safety regulations.

 **Caution:** **Caution** indicates a hazard with a low level of risk which, if not avoided, could result in minor or moderate injury.

 **Warning:** **Warning** indicates a hazard with a medium level of risk which, if not avoided, could result in death or serious injury.

 **Danger:** **Danger** indicates a hazard with a high level of risk which, if not avoided, will result in death or serious injury.

\*1) ISO 4414: Pneumatic fluid power – General rules relating to systems.  
ISO 4413: Hydraulic fluid power – General rules relating to systems.  
IEC 60204-1: Safety of machinery – Electrical equipment of machines.  
(Part 1: General requirements)  
ISO 10218-1: Manipulating industrial robots – Safety.  
etc.

### Warning

#### 1. The compatibility of the product is the responsibility of the person who designs the equipment or decides its specifications.

Since the product specified here is used under various operating conditions, its compatibility with specific equipment must be decided by the person who designs the equipment or decides its specifications based on necessary analysis and test results. The expected performance and safety assurance of the equipment will be the responsibility of the person who has determined its compatibility with the product. This person should also continuously review all specifications of the product referring to its latest catalog information, with a view to giving due consideration to any possibility of equipment failure when configuring the equipment.

#### 2. Only personnel with appropriate training should operate machinery and equipment.

The product specified here may become unsafe if handled incorrectly. The assembly, operation and maintenance of machines or equipment including our products must be performed by an operator who is appropriately trained and experienced.

#### 3. Do not service or attempt to remove product and machinery/equipment until safety is confirmed.

1. The inspection and maintenance of machinery/equipment should only be performed after measures to prevent falling or runaway of the driven objects have been confirmed.
2. When the product is to be removed, confirm that the safety measures as mentioned above are implemented and the power from any appropriate source is cut, and read and understand the specific product precautions of all relevant products carefully.
3. Before machinery/equipment is restarted, take measures to prevent unexpected operation and malfunction.

#### 4. Contact SMC beforehand and take special consideration of safety measures if the product is to be used in any of the following conditions.

1. Conditions and environments outside of the given specifications, or use outdoors or in a place exposed to direct sunlight.
2. Installation on equipment in conjunction with atomic energy, railways, air navigation, space, shipping, vehicles, military, medical treatment, combustion and recreation, or equipment in contact with food and beverages, emergency stop circuits, clutch and brake circuits in press applications, safety equipment or other applications unsuitable for the standard specifications described in the product catalog.
3. An application which could have negative effects on people, property, or animals requiring special safety analysis.
4. Use in an interlock circuit, which requires the provision of double interlock for possible failure by using a mechanical protective function, and periodical checks to confirm proper operation.

### Caution

#### 1. The product is provided for use in manufacturing industries.

The product herein described is basically provided for peaceful use in manufacturing industries.  
If considering using the product in other industries, consult SMC beforehand and exchange specifications or a contract if necessary.  
If anything is unclear, contact your nearest sales branch.

### Limited warranty and Disclaimer/ Compliance Requirements

The product used is subject to the following “Limited warranty and Disclaimer” and “Compliance Requirements”.

Read and accept them before using the product.

#### Limited warranty and Disclaimer

1. The warranty period of the product is 1 year in service or 1.5 years after the product is delivered, whichever is first.\*2)  
Also, the product may have specified durability, running distance or replacement parts. Please consult your nearest sales branch.
2. For any failure or damage reported within the warranty period which is clearly our responsibility, a replacement product or necessary parts will be provided.  
This limited warranty applies only to our product independently, and not to any other damage incurred due to the failure of the product.
3. Prior to using SMC products, please read and understand the warranty terms and disclaimers noted in the specified catalog for the particular products.

##### \*2) Vacuum pads are excluded from this 1 year warranty.

A vacuum pad is a consumable part, so it is warranted for a year after it is delivered.  
Also, even within the warranty period, the wear of a product due to the use of the vacuum pad or failure due to the deterioration of rubber material are not covered by the limited warranty.

#### Compliance Requirements

1. The use of SMC products with production equipment for the manufacture of weapons of mass destruction (WMD) or any other weapon is strictly prohibited.
2. The exports of SMC products or technology from one country to another are governed by the relevant security laws and regulations of the countries involved in the transaction. Prior to the shipment of a SMC product to another country, assure that all local rules governing that export are known and followed.

### Caution

#### SMC products are not intended for use as instruments for legal metrology.

Measurement instruments that SMC manufactures or sells have not been qualified by type approval tests relevant to the metrology (measurement) laws of each country. Therefore, SMC products cannot be used for business or certification ordained by the metrology (measurement) laws of each country.

## Safety Instructions

Be sure to read the “Handling Precautions for SMC Products” (M-E03-3) and “Operation Manual” before use.