

Hydraulic Related Products

Air-Hydro Booster

Made to Order

Converts air pressure to hydraulic pressure for high pressure hydraulic cylinder actuation.

- Generates 3.5 to 14 MPa hydraulic pressure with 0.5 MPa air pressure.
- No hydraulic pump is required. High hydraulic pressure can easily be obtained.
- Hydraulic pressure can be steplessly controlled by only adjusting the air pressure using the regulator.
- There is no trouble due to temperature rise even under the condition of continuous pressurization.
- You can select from two types of pressurization methods (direct type and pre-load type) according to the application.

Applications

- For lifting work pieces
- For automatic clamping devices
- Hydraulic pressure source for low profile hydraulic cylinders



Pressurization Methods

There are two types of air-hydro boosters: direct type and pre-load type.

1 Direct Type

This is suitable when high power is required over the entire stroke, such as moving a work piece in a short distance.

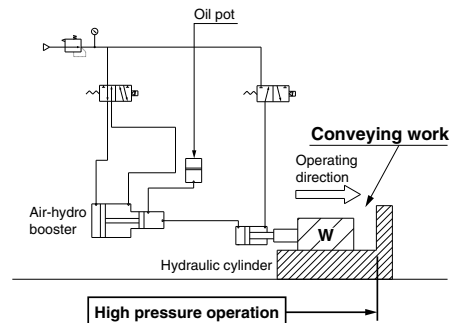

2 Pre-load Type

This is suitable when pressurizing a work piece after moving it in position using a hydraulic cylinder. The pre-load type requires an air-hydro converter (Series CCT).

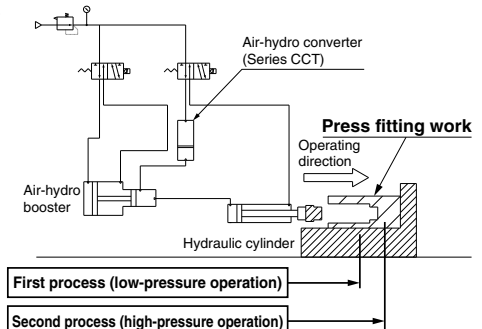

| |
|------------------------------|
| CHQ |
| CHK <input type="checkbox"/> |
| CHN |
| CHM |
| CHS <input type="checkbox"/> |
| CH2 <input type="checkbox"/> |
| CHA |
| Related Products |
| D- <input type="checkbox"/> |

Hydraulic Related Products / Air-Hydro Booster

Specifications

| Part number | CQ2L160-DCG5643G-17 | CQ2L160-DCG5644G-101 | CQ2L100-Z4195-60 | CQ2L140-DCG5645G-17 | CQ2F100-Z4239-60 | CQ2LH160-DCG864AG-105 | CQ2LH160-20-DCI9145I |
|--|--------------------------------|----------------------|--------------------|---------------------|--------------------|-----------------------|----------------------|
| Air pressure cylinder diameter | ø160 | ø160 | ø100 | ø140 | ø100 | ø160 | ø160 |
| Pressure increase ratio | 1 : 7 | 1 : 10 | 1 : 13 | 1 : 15 | 1 : 16 | 1 : 25 | 1 : 32.6 |
| Amount of discharged oil | 17 cm ³ | 101 cm ³ | 60 cm ³ | 17 cm ³ | 60 cm ³ | 105 cm ³ | 20 cm ³ |
| Maximum working pressure (air pressure) | 1.0 MPa | | | | 0.87 MPa | 0.56 MPa | 0.43 MPa |
| Generated hydraulic pressure (with 0.5 MPa air pressure) | 3.5 MPa | 5.0 MPa | 6.5 MPa | 7.5 MPa | 8.0 MPa | 12.5 MPa | 14 MPa* |
| Fluid | Air | | | | | | |
| Hydraulic pressure | Turbine oil class 1 (ISO VG32) | | | | | | |
| Ambient and fluid temperature | 5 to 60°C | | | | | | |
| Oil pot | With oil pot | With oil pot | With oil pot | With oil pot | Without oil pot | Without oil pot | With oil pot |

* The value when the maximum working pressure of 0.43 MPa is applied.

Dimensions

CQ2L160-DCG5643G-17 (pressure increase ratio: 1 to 7) / Wall mount type

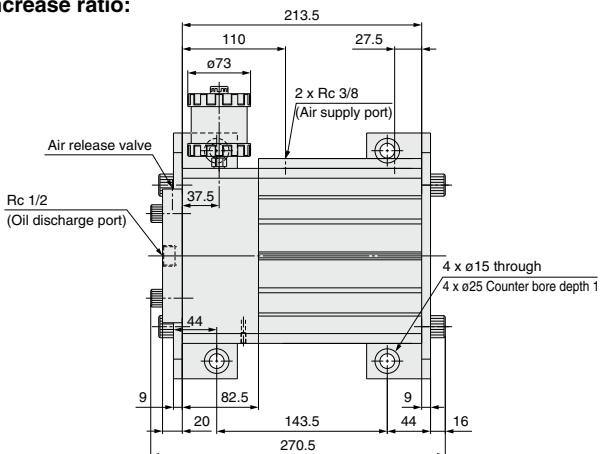
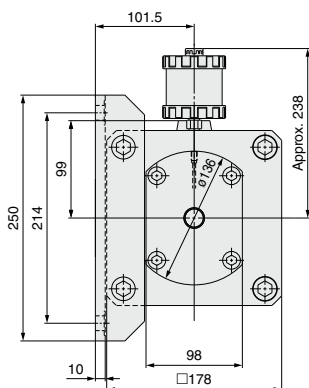

CQ2L160-DCG5644G-101 (pressure increase ratio: 1 to 10) / Wall mount type

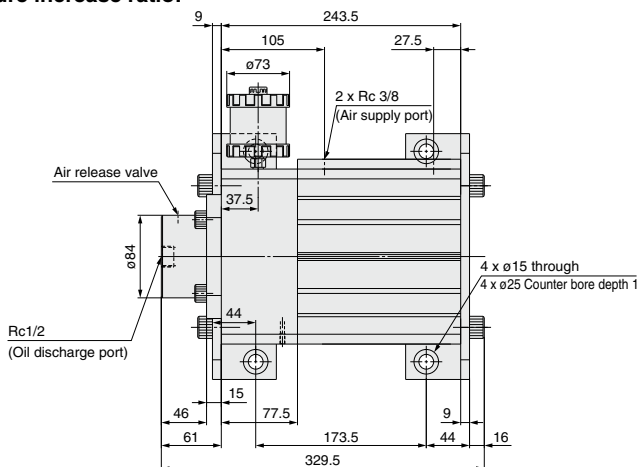
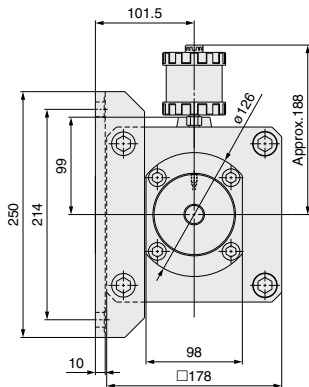

Hydraulic Related Products / Air-Hydro Booster

Dimensions

CQ2LH160-DCG864AG-105 (pressure increase ratio: 1 to 25) / Horizontal mount type

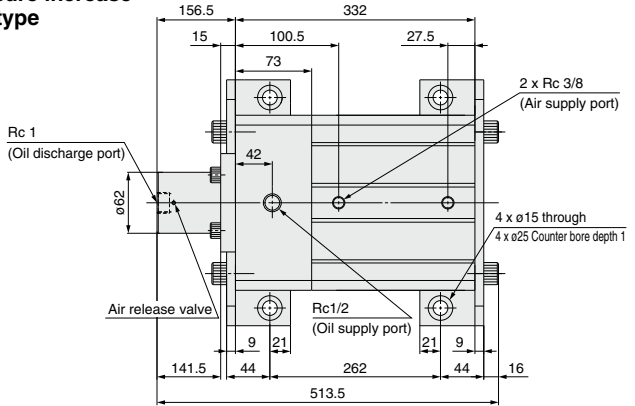
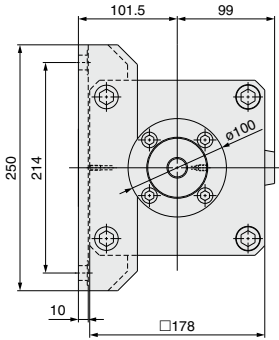

CQ2L100-Z4195-60 (pressure increase ratio: 1 to 13) / Wall mount type

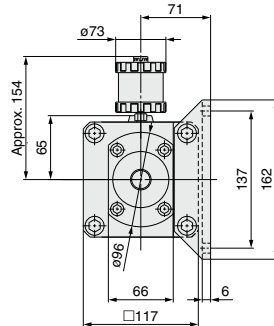
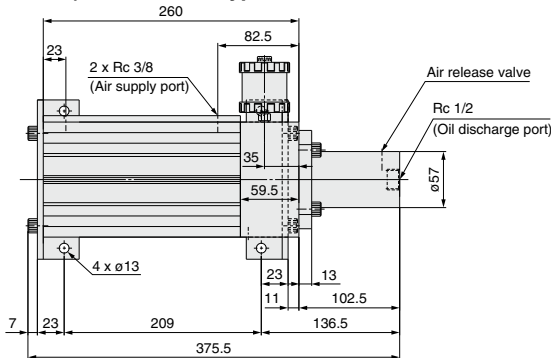

CQ2L140-DCG5645G-17 (pressure increase ratio: 1 to 15) / Wall mount type

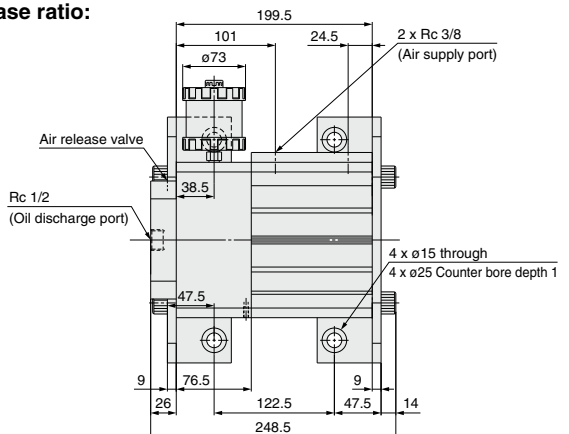
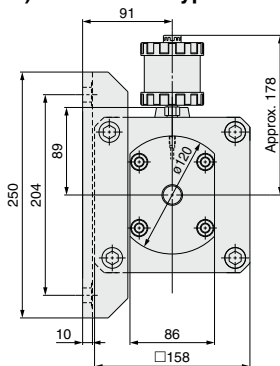

CHQ

CHK

CHN

CHM

CHS

CH2

CHA

Related Products

D-

Hydraulic Related Products / Air-Hydro Booster

Dimensions

CQ2F100-Z4239-60 (pressure increase ratio: 1 to 16) / Horizontal mount type

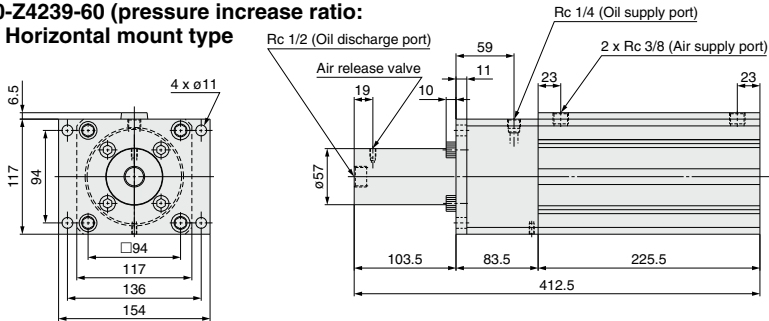

CQ2LH160-20-DCI9145I (pressure increase ratio: 1 to 32.6) / Horizontal mount type

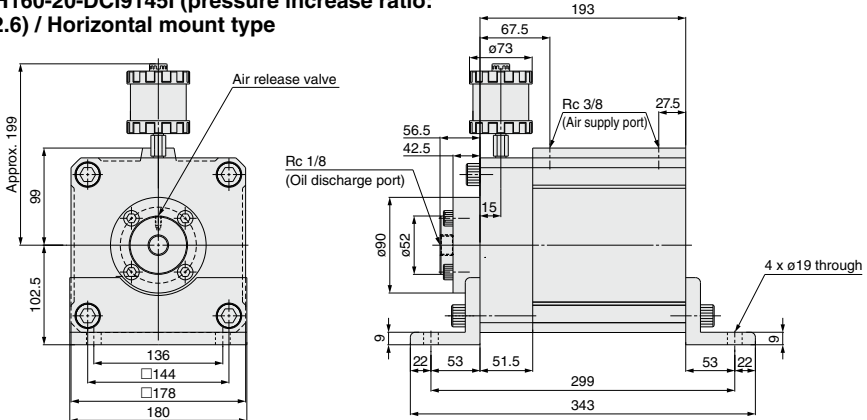

Special order products other than those listed here are available. Please contact SMC for details.

⚠ Product Specific Precautions

Be sure to read this before handling the Products. Refer to back page 50 for Safety Instructions and pages 214 to 221 for Hydraulic Cylinders and Auto Switches Precautions.

1. The hydraulic fluid in the oil pot or the air-hydro converter of the air-hydro booster (hereafter referred to as "the booster") may become black and cloudy. This is caused by the mixing in of powder from the initial abrasion of the seals in the booster (minimal abrasion that does not affect the performance of the seals), and a phenomenon that cannot be avoided. The performance of the booster is not compromised with the hydraulic fluid black and cloudy.

⚠ Caution

1. The oil level in the oil pot and the air-hydro converter may become higher than the initial level when the booster is stopped for a long period of time after a long period of operation. This is caused because air is accumulated in the piping between the booster and the hydraulic cylinder and the volume of the entire piping is increased. In this case, please release the air from the hydraulic piping. Otherwise, oil may spout from the breathing hole of the oil supply plug when the booster is started.

⚠ Caution

2. It is recommended that the booster is installed in a location higher than that of the hydraulic cylinder. If it is necessary to install the booster in a location lower than that of the hydraulic cylinder, or if you install piping with many bends, install an air release valve at the uppermost location in the piping. Then, please release the air periodically.
3. If your air-hydro booster is one with an oil pot, the oil supply plug of the oil pot has a breathing hole and oil may leak from the hole depending on the mounting orientation. If such oil leakage is assumed due to the mounting orientation of the air-hydro booster, reconnect the oil pot using a pipe or fitting so that the oil pot is vertical and facing up. Then, please release the air periodically.

Hydraulic Related Products

Air-Hydro Unit CC

Refer to Best Pneumatics No. 2-1 for details.



Air-hydro unit



Converter

| Type | Series | Nominal diameter (mm) |
|----------------|---|-----------------------|
| Air-hydro unit | CC | 63, 100, 160 |
| Converter | CCT | 40, 63, 100, 160 |
| Valve unit | CCV | — |
| Features | <ul style="list-style-type: none"> By converting air pressure into hydraulic pressure, functions that are the same as those of a hydraulic unit can be obtained while using pneumatic equipment. | |

CHQ

CHK

CHN

CHM

CHS

CH2

CHA

Related Products

D-